



BRAVE / ARCHITECTURE

4617 Montrose Blvd., Ste C230
Houston, Texas 77006
713.524.5858 v / 713.524.5868 f
studio@bravearchitecture.com

B/A PROJ. #: 15137
DATE: 2.23.2016
ISSUE: PERMIT

DATE: 5.4.2016
ISSUE: PERMIT COMMENTS

SUNSET COFFEE SHOP

1019 Commerce St. / Houston, Texas 77002



PROJECT TEAM:

ARCHITECT _____ BRAVE / ARCHITECTURE

MEP _____ COLLABORATIVE ENGINEERING GROUP

COVER PAGE

GENERAL INFORMATION

G.000.1 Index, General Information, Legend
G.000.2 Index, General Information, Legend
G.000.4 Specifications
G.000.5 Specifications
G.000.6 Specifications

ARCHITECTURAL

DEMOLITION PLANS

D.101 Demolition Floor Plan
D.201 Demolition Reflected Ceiling Plan

FLOOR PLANS

A.101 Floor Plan
A.110 Enlarged Ground Floor Plan(s)
A.151 Finish Floor Plan & Schedule
A.153 Furniture Layout

REFLECTED CEILING PLANS

A.201 Reflected Ceiling Plan

INTERIOR DETAILS

A.701 Interior Elevations
A.702 Interior Elevations
A.710 Casework Elevations & Details
A.711 Casework Elevations & Details
A.740 Ceiling Details

SCHEDULES

A.820 Door Types & Schedule

MECHANICAL

M0.00 Mechanical Symbols & Abbreviations
M0.01 Mechanical Demolition Floor Plan
M1.01 Mechanical Floor Plan
M4.00 Mechanical Schedules
M5.00 Mechanical Details
M6.00 Mechanical Specifications

ELECTRICAL

E0.00 Electrical Symbols & Abbreviations
E0.01 Electrical Specifications
E1.01 Electrical Lighting Floor Plan
E1.11 Electrical Lighting Demolition Plan
E2.01 Electrical Power Floor Plan
E2.11 Electrical Power Demolition Plan
E6.00 Electrical One Line, Load Analysis, & Fault Analysis
E8.00 Electrical Schedules
E8.01 Electrical Schedules
E9.00 Electrical Details

PLUMBING

P0.00 Plumbing, Symbols and Abbreviations
P1.01 Plumbing Floor Plan

PROJECT NAME: SUNSET COFFEE

PROJECT LOCATION: 1019 COMMERCE STREET, HOUSTON, TX 77002

SCOPE OF WORK: TENANT IMPROVEMENT INTERIOR RENOVATION FOR A COFFEE SHOP

GOVERNING AGENCIES: CITY OF HOUSTON, HARRY COUNTY, HARRY COUNTY FLOOD CONTROL DISTRICT

GOVERNING CODE(S): 2012 INTERNATIONAL BUILDING CODE W/ COH AMENDMENTS
2012 INTERNATIONAL FIRE CODE W/ COH AMENDMENTS
2012 UNIFORM MECHANICAL CODE W/ COH AMENDMENTS
2012 UNIFORM PLUMBING CODE W/ COH AMENDMENTS
2014 NATIONAL ELECTRICAL CODE W/ COH AMENDMENTS
2009 INTERNATIONAL ENERGY CONSERVATION CODE W/ COH AMENDMENTS
2012 TEXAS ACCESSIBILITY STANDARDS WITH LATEST AMENDMENTS

OCCUPANCY CLASSIFICATION: A-2

CONSTRUCTION TYPE: EXISTING TO REMAIN, TYPE IIA
SPRINKLERED

OCCUPANT LOAD: ASSEMBLY WITHOUT FIXED SEATS
UNCONCENTRATED (INCLUDES CAFE/RETAIL RM 102, BAR RM 102.1, AND TERRACE RM 102.3)
2790 SF/15 NET = 186 OCC.
KITCHEN, COMMERCIAL (CATERING RM 110)
200 SF/200 GROSS = 1 OCC.

PLUMBING FIXTURE REQUIREMENTS: A-2 (ALL PLUMBING FIXTURES EXISTING TO REMAIN)

WATER CLOSETS: 187 OCC./2 = 94/1 PER 45 = 1.25 MALE AND 1.25 FEMALE = 4
EXISTING ON CAFE LEVEL = OK

LAVATORIES: 187 OCC./2 = 94/1 PER 200 = .47 MALE AND .47 FEMALE = 4
EXISTING ON CAFE LEVEL = OK

SHOWERS: NONE REQUIRED

DRINKING FOUNTAIN: 1 PER 500 = 0.37 - 2 EXISTING ON CAFE LEVEL = OK

SERVICE SINK: 1 SERVICE SINK EXISTING

* EXISTING GREASE TRAP TO REMAIN

PARKING REQUIREMENTS: EXISTING METERED PARKING TO REMAIN

PROPOSED BUSINESS TYPE: CAFE

* SCOPE INCLUDES INTERIOR DEMOLITION OF SOME PARTITIONS, RELOCATION OF EXISTING DOOR. NEW CONSTRUCTION INCLUDES NEW FINISHES, PARTITIONS, NEW DOOR, MILLWORK, AND MEP CONNECTIONS FOR COFFEE EQUIPMENT. EXISTING SHELL STRUCTURE, DEMISING WALLS, AND STOREFRONT TO REMAIN.

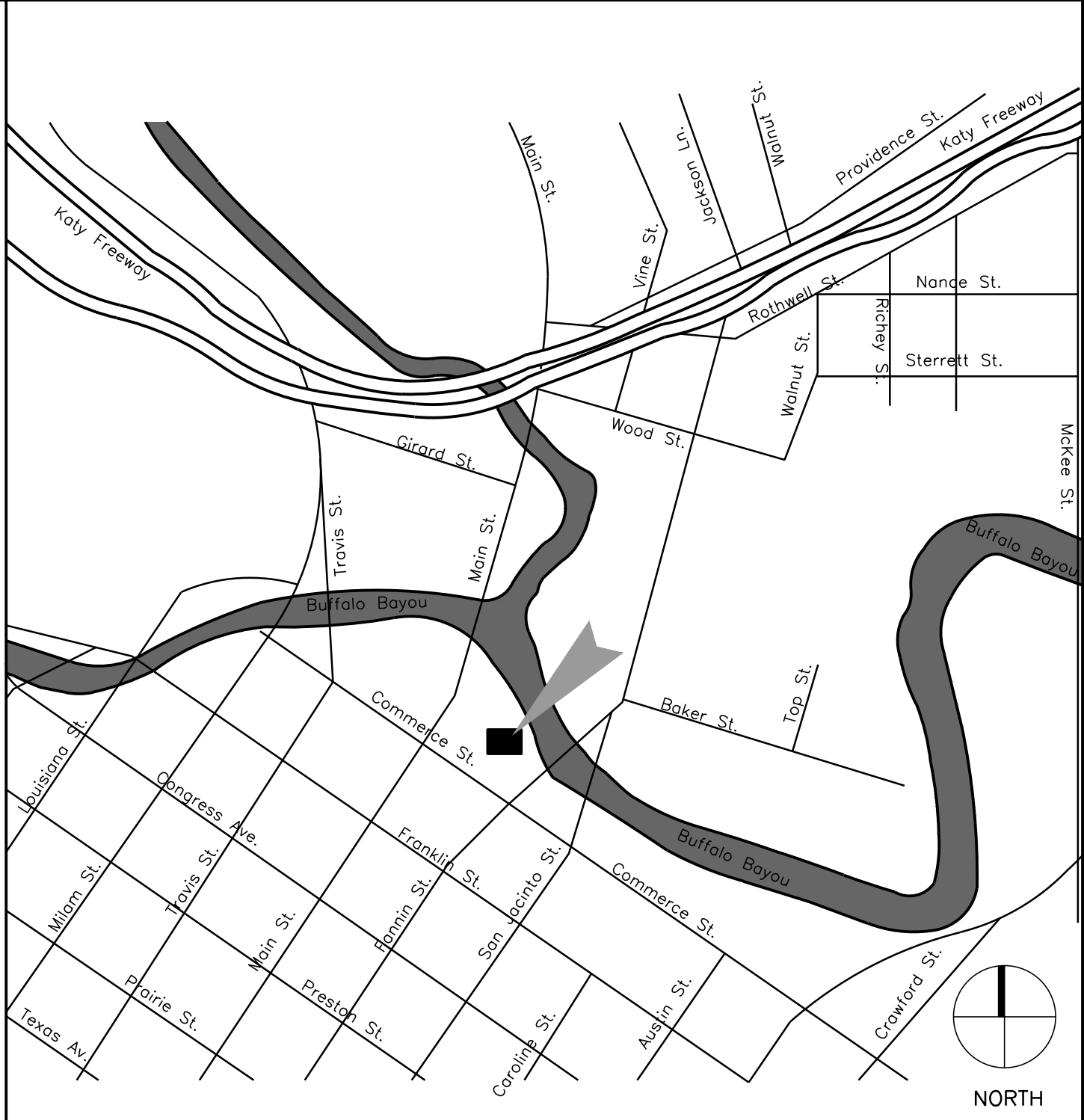

B/A

BRAVE / ARCHITECTURE

4617 Montrose Blvd., Suite C.230
Houston, Texas 77006
Voice: 713.524.5858
Fax: 713.524.5868
studio@bravearchitecture.com
Contact: Silvana Micolich
smicolich@bravearchitecture.com



Consultants:

MEP:

Collaborative Engineering Group
8904 Fairbanks N. Houston Suite 201
Houston, TX 77064
T: 281.598.1170
F: 281.598.1130

SHEET INDEX | 9 **PROJECT DESCRIPTION** | 6 **SITE LOCATION MAP** | 3

- THESE DRAWINGS INDICATE THE GENERAL SCOPE OF THE PROJECT IN TERMS OF THE ARCHITECTURAL DESIGN CONCEPT, THE MAJOR DIMENSIONS, AND THE MAJOR ARCHITECTURAL, STRUCTURAL, MECHANICAL & PLUMBING ELEMENTS.
- AS SCOPE DOCUMENTS THEY DO NOT NECESSARILY INDICATE ALL WORK REQUIRED FOR FULL PERFORMANCE AND COMPLETION OF THE JOB. ON THE BASIS OF THE GENERAL WORK INDICATED, ALL CONTRACTORS (AND SUBCONTRACTORS) SHALL FURNISH ALL ITEMS REQUIRED FOR THE PROPER EXECUTION AND TIMELY COMPLETION OF THE WORK.
- PRIOR TO STARTING CONSTRUCTION, THE CONTRACTOR SHALL BE RESPONSIBLE TO VERIFY THAT ALL REQUIRED PERMITS AND APPROVALS HAVE BEEN OBTAINED. NO CONSTRUCTION OR FABRICATION OF ANY ITEM SHALL BEGIN UNTIL THE CONTRACTOR HAS RECEIVED ALL PLANS AND ANY OTHER DOCUMENTATION FROM ALL OF THE PERMITTING AND ANY OTHER REGULATORY AUTHORITIES. FAILURE OF THE CONTRACTOR TO FOLLOW THIS PROCEDURE SHALL CAUSE THE CONTRACTOR TO ASSUME FULL RESPONSIBILITY FOR ANY SUBSEQUENT MODIFICATION OF THE WORK MANDATED BY ANY REGULATORY AUTHORITY.
- ALL WORK SHALL COMPLY WITH APPLICABLE STATE AND LOCAL CODES AND ALL NECESSARY LICENSES AND PERMITS SHALL BE OBTAINED BY THE CONTRACTOR AT HIS EXPENSE UNLESS PREVIOUSLY OBTAINED BY THE OWNER.
- ALL WORK SHALL BE PERFORMED IN A FINISHED AND WORKMANLIKE MANNER TO THE ENTIRE SATISFACTION OF THE OWNER & ARCHITECT AND IN ACCORDANCE WITH THE BEST RECOGNIZED TRADE PRACTICES.
- CONTRACTOR WILL BE HELD TO HAVE STUDIED THE DRAWINGS, TO HAVE VISITED THE SITE, AND TO HAVE SATISFIED HIMSELF REGARDING ALL EXISTING CONDITIONS UNDER WHICH HE WILL BE OBLIGED TO OPERATE. CONTRACTOR SHALL IMMEDIATELY REPORT ANY ERROR, INCONSISTENCY OR OMISSION TO THE ARCHITECT.
- CONTRACTOR IS TO PROVIDE AND INSTALL ALL NECESSARY PROTECTIVE DEVICES REQUIRED TO PROTECT ANY OWNER'S FURNISHED EQUIPMENT INSTALLED PRIOR TO THE COMPLETION OF THE WORK.
- CONTRACTOR SHALL COORDINATE ALL DELIVERIES AND ACCESSIBILITY TO THE BUILDING FOR ALL ITEMS.
- IT SHALL BE THE CONTRACTOR'S RESPONSIBILITY TO VERIFY THE LOCATIONS OF ALL UTILITIES WITHIN THE LIMITS OF THE WORK PRIOR TO THE START OF SITE WORK. ALL DAMAGES MADE TO THE EXISTING UTILITIES BY THE CONTRACTOR SHALL BE THE SOLE RESPONSIBILITY OF THE CONTRACTOR.
- CONTRACTOR SHALL INCLUDE ALL LABOR, MATERIALS, EQUIPMENT, FIXTURES, AND SERVICE NECESSARY FOR THE PROPER EXECUTION OF THE WORK SHOWN ON THE PLANS.
- ALL MATERIALS AND EQUIPMENT INCORPORATED IN THE WORK SHALL BE NEW AND ALL WORK BE OF GOOD QUALITY, FREE FROM FAULTS, AND IN CONFORMANCE WITH THE PLANS.
- CONTRACTOR SHALL KEEP THE PREMISES FREE FROM ACCUMULATION OF WASTE MATERIALS OR RUBBISH CAUSED BY HIS OPERATIONS. AT THE COMPLETION OF THE WORK HE SHALL PERFORM A FINAL CLEAN-UP, INSIDE AND OUT, CLEAN ALL GLASS SURFACES AND LEAVE THE PROJECT AREA CLEAN.
- CONTRACTOR SHALL GUARANTEE FOR 1 (ONE) YEAR THAT ALL OF THE WORK UNDER THE CONTRACT IS FREE FROM FAULTY MATERIALS, WATER-TIGHT AND LEAK-PROOF IN EVERY PARTICULAR AND FREE FROM IMPROPER WORKMANSHIP.
- CONTRACTOR SHALL SUPERVISE THE WORK AND COORDINATE ALL PORTIONS THEREOF.
- CONTRACTOR SHALL BE RESPONSIBLE FOR PROTECTION OF EXISTING AND NEW WORK. ANY WORK DAMAGE FOR ANY REASON SHALL BE REPLACED AT NO COST TO THE OWNER.
- CONTRACTOR SHALL NOT SCALE DRAWINGS - LARGER DRAWINGS AND DETAILS SHALL TAKE PRECEDENCE OVER SMALLER REFERENCED DRAWINGS AND DETAILS.
- THESE DRAWINGS AND COPIES THEREOF ARE TO BE USED ONLY FOR THIS PROJECT AND ARE NOT TO BE USED IN CONNECTION WITH ANY OTHER PROJECT. CHANGES TO THE DRAWINGS MAY ONLY BE MADE BY THE ARCHITECT. ANY SUBMISSION, DUPLICATION OR DISTRIBUTION OF THESE DRAWINGS WITHOUT THE WRITTEN CONSENT OF THE ARCHITECT MAY BE CONSIDERED AS DEROGATION OF THE ARCHITECT'S COPYRIGHT OR OTHER RESERVED RIGHTS.

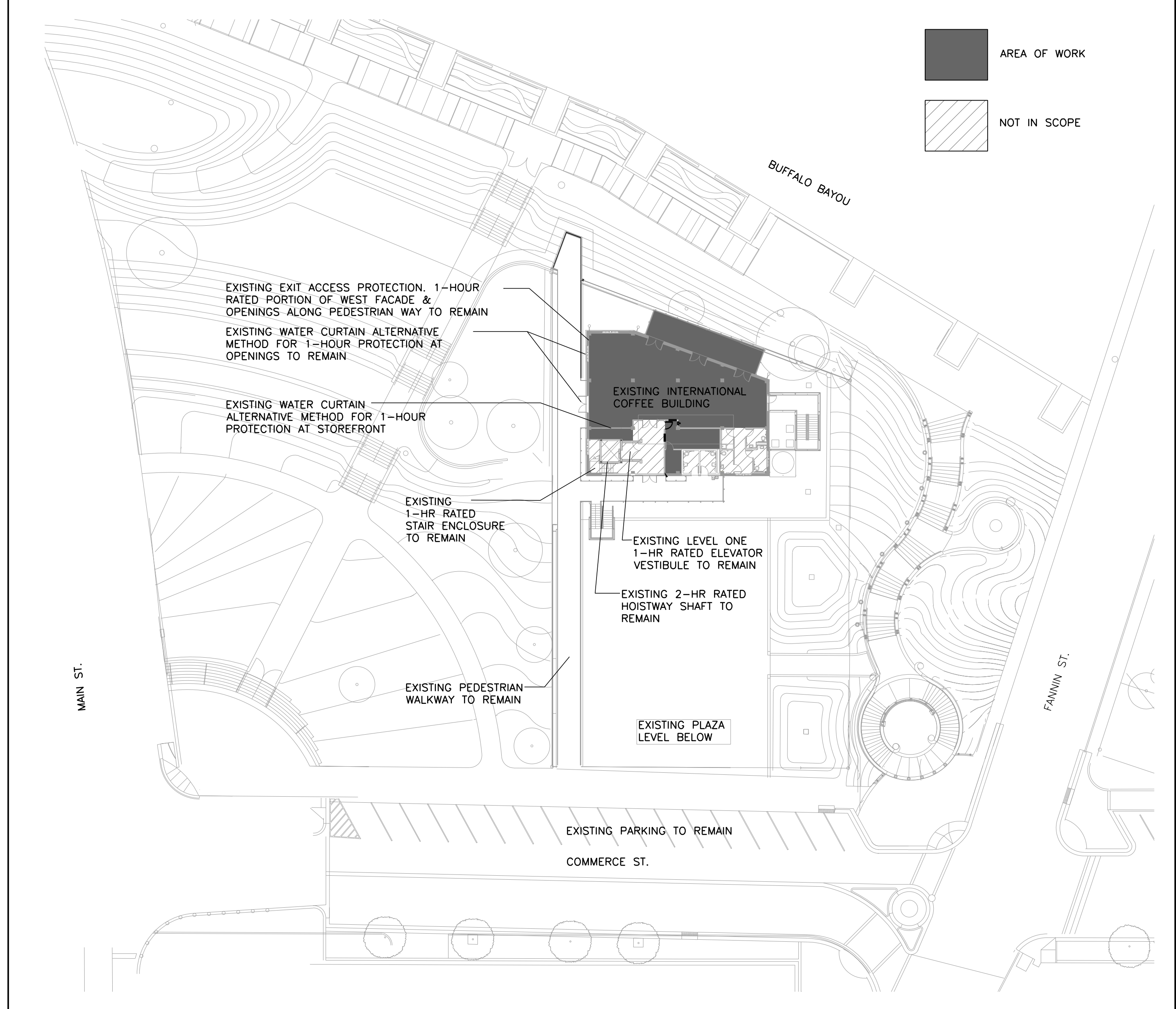
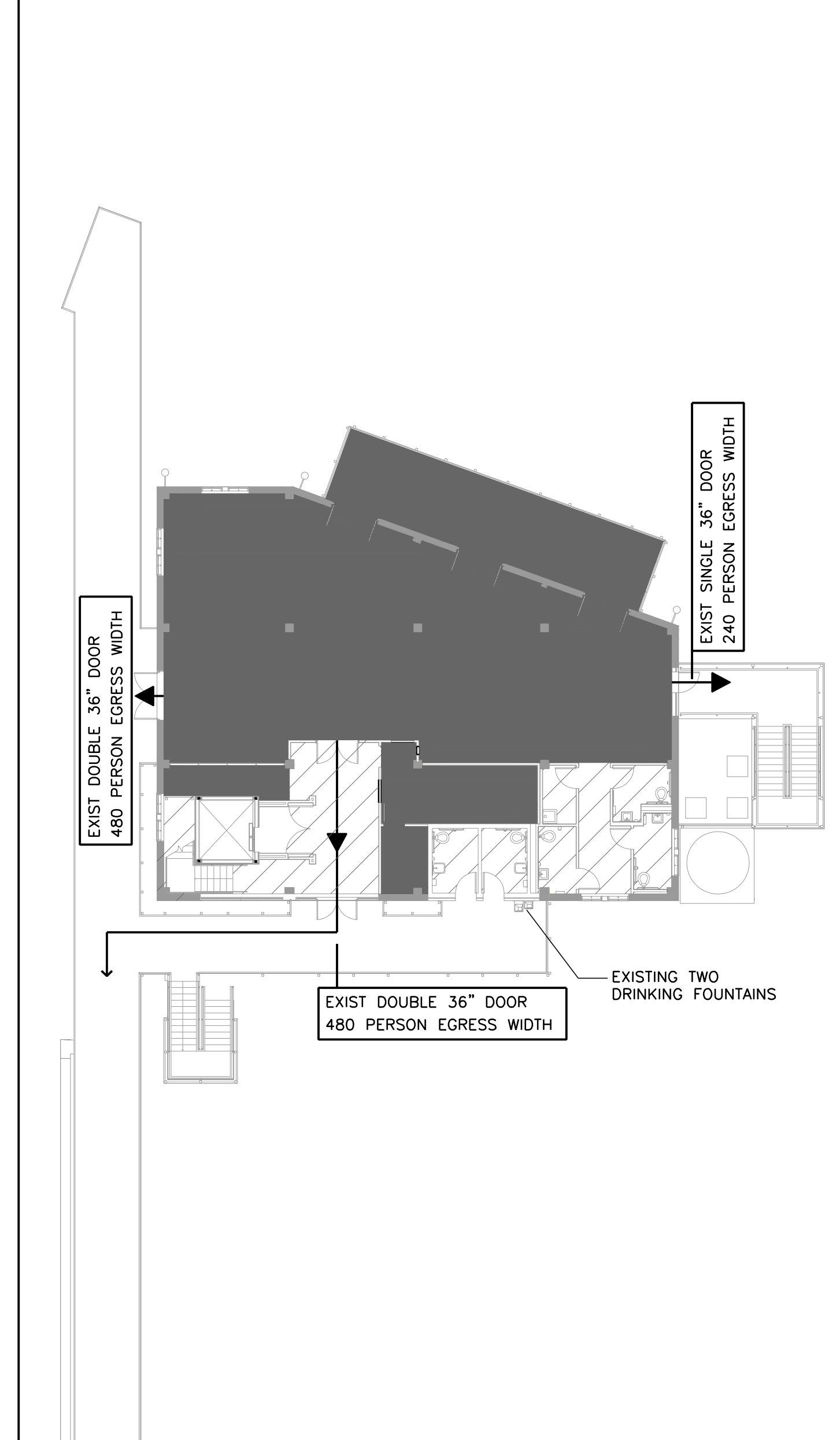

GENERAL INFORMATION | 10 **EGRESS PLAN** | 1/16" = 1'-0" | 7 **SITE PLAN** | 1/32" = 1'-0" | 1

SUNSET COFFEE

1019 Commerce St.
Houston, TX 77002

Ownership of Instruments of Service:
All reports, plans, specifications, computer files, field data, notes & other documents and instruments prepared by BRAVE / ARCHITECTURE as instruments of service shall remain the property of BRAVE / ARCHITECTURE. BRAVE / ARCHITECTURE shall retain all common law, statutory and other reserved rights, including the copyright thereto.

Issue:

2016.2.17 OWNER FINAL REVIEW
2016.2.23 PERMIT

B/A Project No.: 15137
Drawn By: MM
Checked By: SM
Date:
Scale: AS NOTED

GENERAL INFORMATION

G.000.1



Consultants:

MEP:
Collaborative Engineering Group
8904 Fairbanks N. Houston Suite 201
Houston, TX 77064
T: 281.598.1170
F: 281.598.1130

SUNSET COFFEE

1019 Commerce St.
Houston, TX 77002

Ownership of Instruments of Service:
All reports, plans, specifications, computer files, field data, notes & other documents and instruments prepared by BRAVE / ARCHITECTURE as instruments of service shall remain the property of BRAVE / ARCHITECTURE. BRAVE / ARCHITECTURE shall retain all common law, statutory and other reserved rights, including the copyright thereto.

Issue:

2016.2.17 OWNER FINAL REVIEW
2016.2.23 PERMIT

B/A Project No.: 15137
Drawn By: MM
Checked By: SM
Date:
Scale: AS NOTED

GENERAL INFORMATION

Table of abbreviations for architectural drawings, including terms like ANCHOR BOLT, ACUSTICAL, ADA, etc., organized in columns.

Table of M.E.P. floor plan drawing symbols, including symbols for floor duplex outlet, floor telephone outlet, floor data outlet, etc.

Table of material conventions, including symbols for loose earth fill, compacted earth fill, rock fill, common brick, etc.

Table of drawing symbols, including symbols for north symbol, working point, existing grade elevation, new grade / slab elevation, boundary of work area, etc.

4617 Montrose Blvd., Suite C.230
Houston, Texas 77006
Voice: 713.524.5858
Fax: 713.524.5868
studio@bravearchitecture.com
Contact: Silvana Micolich
smicolich@bravearchitecture.com



Consultants:
MEP:
Collaborative Engineering Group
8904 Fairbanks N. Houston Suite 201
Houston, TX 77064
T: 281.598.1170
F: 281.598.1130

SUNSET COFFEE

1019 Commerce St.
Houston, TX 77002

Ownership of Instruments of Service:
All reports, plans, specifications, computer files, field data, notes & other documents and instruments prepared by BRAVE / ARCHITECTURE as instruments of service shall remain the property of BRAVE / ARCHITECTURE. BRAVE / ARCHITECTURE shall retain all common law, statutory and other reserved rights, including the copyright thereto.

Issue:
2016.2.17 OWNER FINAL REVIEW
2016.2.23 PERMIT

B/A Project No.: 15137
Drawn By: MM
Checked By: SM
Date:
Scale: AS NOTED

SPECIFICATIONS

CONTRACT DOCUMENTS

Unless agreed otherwise by all parties to this project, the work shall be governed by the American Institute of Architects documents A201, general conditions of the contract for construction and A101, standard of agreement between owner and contractor; both 2007 edition.

CONSTRUCTION DOCUMENTS

- 1. These construction documents describe the construction of interior tenant build out of "SUNSET COFFEE SHOP"
2. The construction documents consist of this complete set of drawings, specifications, and notes; as well as all related documents and manuals referred to within these drawings and notes as applicable.
3. The various construction documents are interrelated as follows:
(a.) The general notes and general conditions define the rules and conditions governing the work.
(b.) The specifications, where included as part of the construction documents or as separate documents, provided more detailed requirements on the rules and conditions governing the work as well as providing both general and specific information regarding the types and qualities of materials and workmanship to be used in the work.
(c.) The drawings show both graphically and by notation the physical characteristics and requirements of the work, including descriptions of materials, colors, finishes, systems, and equipment to be used in the execution of the work.
(d.) In general, larger-scale drawings take precedence over smaller-scale drawings; written drawing keynotes take precedence over pictorial representations in the drawings; and written dimensions take precedence over scaled dimensions.
4. Familiarity with these documents by all contractors and subcontractors involved in this work is required. The conditions listed below are provided for quick reference and summary, where similar conditions occur in AIA document A201; the more stringently worded condition shall prevail. AIA document A201 is available for purchase at the local AIA chapter office.

GENERAL CONDITIONS REQUIREMENTS AND SCOPE OF WORK

GENERAL / MISCELLANEOUS

- 1. The architect shall be the primary source of information regarding the construction documents. All communication with the architect shall be only from the general contractor or their representative. All questions, concerns, or comments from sub-contractors, suppliers, or any other parties involved in the construction of the project under contract to one of these contractors, shall be channeled through the primary contractor.
2. The construction documents are intended to convey the owner's and architect's design intent for the final appearance and functionality of the project in sufficient detail that the contractor can accurately price and build the project. As such, the construction documents illustrate major systems and components and define the primary characteristics of shape, color, material, size, and quantity that are needed in order to realize the design intent. Items which are miscellaneous in nature, or which are well-understood industry standards required to properly complete major systems or components described in these construction documents should not be expected to be fully defined or specified in these construction documents.
3. In all cases where the construction documents may disagree among themselves, the contractor shall contact the architect for clarification before proceeding. In such cases during the bidding process and when timely clarification is not possible, contractor shall price the most expensive alternative in combination of quantity and quality, and shall alert the architect to that effect.
4. Do not scale drawings. Use figure dimensions only. In the event of discrepancy between existing field conditions and figure dimensions or drawings, or discrepancies between the drawings themselves, the contractor is to notify architect immediately for resolution before proceeding. The scale noted on the construction drawings is for general reference only, and allows the observer to place the drawing and/or detail in question in context within other drawings in the construction documents, this notwithstanding, due to the reproduction process, all copies of original drawings must be considered to be not to scale.
5. All work that is either implied or reasonably inferred from the contract documents, drawings, and specifications, shall be the responsibility of the general contractor unless specifically indicated otherwise. All drawings, documents, and specifications are directed to the attention of the general contractor, and the inclusion of any work by mention, note, drawing, detail, itemization, or implication, however brief, means that the general contractor is to provide and install such work.
6. Each general contractor is to visit the project site during the bidding or negotiating period to verify the existing site conditions, including site utilities, floor elevations, existing improvements requiring demolition, existing base building structure, and the general conditions of the project site. Should the general contractor find any conditions which differ substantially from conditions shown within these drawings, or that would prevent the work from proceeding in accordance with these drawings, it is the general contractor's responsibility to notify the owner and the architect and to account for these differing conditions in the submitted bid or negotiated price. Modifications to contract sum or schedule will be allowed only for conditions which are discovered as a result of cutting and patching or during demolition operations. No changes in the contract sum or schedule will be allowed for exposed conditions, or conditions visible by entry into access doors or occluded ceilings, or by conditions described in base building drawings or these construction documents.
7. Certain conditions may require work for different trades to be shown or noted in sheets other than the trade-specific sections. It is the general contractor's responsibility to have thorough knowledge and understanding of all construction drawings and other contract documents, particularly as it affects the coordination, interphase, and responsibilities of all sub-contractors' work, to ascertain that the full scope-of-the work of each trade and the areas of overlap or connection between trades, (whether shown or not in the sheets assigned to the specific trades), are completely provided for in the base bid price and will be provided for in the work.
8. Work to be performed or items to be purchased and installed by the general contractor are shown in these contract documents both pictorially and by notation. Both ways of presenting information are to be considered equally binding upon the general contractor to provide the required work or item to the job. This applies to work that is drawn but not notated, or notated but not drawn. If clarification is required, contact the architect before proceeding.
9. In all cases where work depicted in these drawings represents a complete system composed of separate parts, it is the responsibility of the general contractor to provide all the parts, components, accessories, hardware, fasteners, etc., required for the complete and fully functioning assembly within the definitions of normal industry standards, whether or not these miscellaneous items are directly specified in the construction documents.
10. In the bid or negotiated price, the general contractor shall include the coordination of all trades and sub-contractors to insure the successful completion of the work. This shall also include all coordination required with the owner for the successful completion of the project, or any other contractors or consultants hired directly by the owner, such as contractors and consultants may include, but may not be limited to millwork contractor; computer network consultants; communications contractors; security systems contractors; etc.
11. Where specific suppliers and/or contractors for specific items are noted in

- the instruction to bidders or elsewhere within the construction documents is because these suppliers and contractors are known to the architect or the owner as having the skills and capabilities to perform or provide the indicated items of work. The listing of any supplier and/or contractor within these documents is not intended to restrict the general contractor from seeking competitive bids for these items of work, nor does it imply any guarantee or endorsement on the part of the architect or owner that these suppliers or contractors will adequately perform the indicated work, responsibility for coordination, implementation, supervision, and completion of all work is solely that of the general contractor.
12. All material and/or performance specifications, whether included in the construction drawings or issued separately, are correlative with the construction documents and have equal authority and priority. Should they disagree in themselves or with each other, the general contractor shall contact the architect for clarification.
13. All dimensions are to the finish unless noted otherwise.
14. Ceiling height dimensions are from finished floor to finished face of ceiling unless noted otherwise.
15. The general contractor is responsible for obtaining all written dimensions prior to commencement of construction. Note, if demolition is required by scope, field dimensions must be obtained after space is cleared of all debris. All dimensions are required to be figured and snapped on slab prior to commencement of work. Figured layout will require architect's approval prior to commencement of work. All dimensions which do not figure as per floor plan and reflected ceiling plan shall be brought to the architect's immediate attention prior to commencement of work. The general contractor is fully responsible for assuring that dimensions shown in drawing are possible. If dimensions are not possible to achieve, the g.c. must notify architect immediately for a response.
16. Large scale details take precedence over small scale details.
17. Architectural drawings take precedence in regards to dimensions when in conflict with mechanical and structural drawings except for size and spacing of structural members; in case of conflict with the latter, general contractor shall contact architect before proceeding.
18. All work shall be erected plumb, level, square, true, and in proper alignment.
19. Separate materials and components which are to be assembled together in order to make a complete assembly or system are to be of like quality, appearance, and finish. Where possible, such materials or components are to be from the same manufacturer.
20. All gypsum board joints in visible drywall construction and in areas of required fire separation, are to be taped, floated, sanded, and primed for painting or other specified finish as required. Regardless of the gypsum board products used in the work, erection of gypsum board is to be in accordance with industry standards and the standards and recommendations of the United States Gypsum Co. or Georgia-Pacific.
21. All carts, dollies, equipment boxes, etc. that are used on the job are to be equipped with rubber wheels. All ladders, work benches, table saws, and any other equipment that rests on the floor shall likewise have rubber protectors or be placed over a protective cover when used over a finished floor surface. General contractor shall take whatever measures are necessary to see that no finished surfaces, whether floor, wall, or ceiling, is damaged or marred in any way during the construction process. In the event of damage, such damage shall be repaired to like-new condition at no charge to the owner. When repair is impractical or not possible, the damaged finished surface shall be replaced at no charge to the owner. Replaced materials shall match adjacent similar materials in all finish aspects.
22. All materials are to be stored and installed according to the manufacturer's instruction and recommendations unless specifically noted otherwise. If the usage of any material, item of equipment or hardware as depicted in these construction documents is in contradiction to the instructions or recommendations of the manufacturer of that material or item - particularly in instances where the usage depicted in these construction documents would, without the Architect's knowledge, void a manufacturer's warranty - it is the responsibility of the general contractor to notify the architect in writing before proceeding.
23. All materials used in the execution of this project are to be new and unused. All materials used in the project are to arrive at the project site in the original manufacturer's packaging if the material is ordinarily a packaged item.
24. All wood used in this project is to be fire-retardant treated where required by local building codes. This includes finish millwork wood. Combustible material is not allowed above finished ceiling in plenum.
25. Provide all necessary supports or blocking in walls or ceilings as required to support work attached to them such as equipment, shelving, mirrors, cabinets, light fixtures, etc.
26. The General Contractor is responsible for ensuring that the work depicted in these drawings proceeds in accordance with all local, state and federal codes, rules, regulations, ordinances, laws, and insurance underwriter's requirements which might govern this work. General Contractor is responsible for performing all the work specified in these documents within the schedules and hours permitted by the landlord and shall at all times abide by the rules; regulations; conditions; and construction requirements outlined in the LANDLORD DESIGN AND BUILDING CRITERIA. Workmanship and materials workmanship shall comply with the quality, methods, and standards consistent with the best trade practices in effect during the construction of this project. All equipment and materials shall be new, unused, and shall represent the manufacturer's best first-class quality. Defective, damaged, or substandard materials will not be acceptable and, if installed or used, shall be removed and replaced with sound materials or otherwise corrected to the satisfaction of the architect and the owner, with no additional cost to the owner. The owner reserves the right to reject any item seen as unacceptable. The contractor will replace all rejected work under the base bid contract.
27. Dust control
A. Debris, dirt and dust to be kept to a minimum and confined to the immediate construction area.
B. Contractor to isolate construction area from occupied building area by means of temporary partitions or heavy weight drop cloths.
C. Debris, dirt and dust to be cleaned up and cleared from the building site periodically and at a minimum once a week, to avoid excessive accumulation.
D. G.C. to construct complete barricades as required by owner and local ordinance.
28. Noise
A. Construction operations will be confined to normal working hours. Verify allowable working hours with owner and Landlord standards.
B. Contractor must obtain written permission from all affected parties to work other than regular hours.
29. Construction operations will not involve interruption of heating, water, or electrical services without previous notice to owner.

PERMITS, LICENSES AND FEES

Contractor shall be responsible for obtaining all permits and licenses required for the performance of the work and for payment of all associated fees including expediting charges (when applicable). Such costs shall be included as a separate line item within the breakdown of the base bid or negotiated price for the work. Contractor shall be responsible for all miscellaneous fees pertaining to construction imposed by the City.

- 1. General Contractor shall be responsible for all products and materials tests required by city or state ordinances. The cost of such tests shall be included in the base bid or negotiated price, and it shall be listed as a

- separate line item in the cost breakdown
2. All test results shall be made available to the owner, architect, engineers, and other concerned parties.

SUBMITTALS:

GENERAL REQUIREMENTS APPLICABLE TO ALL SUBMITTALS

- 1. All submittals, including shop drawings, are to be reviewed and stamped by the General Contractor to show verification that the submittal conforms to the requirements of the construction documents and provides for the complete scope-of-work required for that item or by the trade preparing the submittal. Submittals and shop drawings will not be considered valid and will not be accepted for review by the architect unless reviewed, stamped, and approved by the general contractor. Adherence to these requirements will not be grounds for the general contractor or any sub-contractor to make claims for additional time and/or cost.
2. All submittals shall be forwarded to the architect for review with sufficient time for the review and approval process to take place, including revisions, resubmittals, and the placing of orders and securing of timely deliveries.
3. The Architect's review of submittals and approval for conformance to design intent does not relieve the Contractor from conformance with the contract documents, nor does it imply approval of changes to the contract documents, whether or not such nonconformities are discovered in the submittals.
4. All submittals shall be fully identified with brand name, product or part number, and intended use within the project.

SUBMITTALS: SHOP DRAWINGS AND PRODUCT DATA

- 1. Unless noted otherwise within the construction documents, general contractor shall submit to architect three (3) copies of all shop drawings and product data for approval. Electronic submittals can be considered if agreed upon by Architect during Construction Kick-off meeting.
2. Minimum size for shop drawing and product data submittals shall be 8-1/2 x 11 inches; maximum size shall be 30 x 42 inches.
3. The contractor is to prepare submittals consisting of product literature, test data, manufacturer's specifications, shop drawings where required - (see below), and samples (when required) for all major systems or items to be included in the project. Such systems or items shall include, but are not necessarily limited to:
A. HVAC systems and components
B. Electrical systems and components
C. Light fixtures
D. Sprinkler system (including cut sheets for heads and escutcheon trims)
E. Fire alarm system
F. Plumbing systems and components
G. Audio/visual systems
H. Storage systems
4. Shop drawings are to be genuine fabrication drawings and are to show all details of configuration, finish, materials, fasteners, joinery, and placement. Shop drawings must be provided for the following:
A. Custom millwork
B. Signage
C. Ornamental metal fabrications
D. Stone panels
E. Metal system
F. Glass and glazing
G. Doors and door hardware.
H. All finish systems (including lay-in ceiling)
5. Shop drawings and submittals are required by owner and architect within 15 working days of an executed contract.

SUBMITTALS: SAMPLES

- 1. Unless noted otherwise within the construction documents, submit three (3) sets for each product sample within the following guidelines:
A. Paint and liquid coated products: minimum size 8-1/2 x 11 inches, maximum 18 inches square; top edge of sample when gypsum board is used as base or substrate; sand smooth edges of plywood or mdf when such materials are used as substrate or when they are submitted as actual material samples.
B. Flat, sheet, or textile products: minimum 6 inches square, maximum 24 inches square.
C. Linear products: minimum 6 inches long, maximum 24 inches long.
D. Bulk products: container label only.
E. Prefabricated products: one complete unit.
F. Masonry, stone, misc. stone: 3 inch x 3 inch samples with polished edges, when metal strips are used, provide sample of same in conjunction with stone sample, for unit masonry submit one (1) unit.
2. Full size or on-site samples or mock-ups may be used in the work when deemed necessary, such on-site samples and/or mock-ups shall fall within the above guidelines for submittals with respect to timing within the construction schedule.

ORDERING OF MATERIALS

The General Contractor is responsible for the timely ordering and arrival of all specified finish materials, equipment, light fixtures, and any other such materials to be utilized on the project. The General Contractor shall notify the architect in writing within 10 days of the date of contract, of any specific items that may not be available within the scheduled requirements of the project. If notification is not received by the Architect, contractor accepts responsibility for the proper ordering and follow-up of specified items, and will pursue whatever means necessary, at no cost to the owner, to insure the availability of all specified items so as not to create a hardship on the owner and not to delay the progress of the work.

REQUESTS FOR SUBSTITUTION

- No substitutions are allowed for the following:
A. light fixtures
B. hardware
1. No substitutions will be reviewed or accepted during the bidding and negotiating period. All pricing is to be for the work as specified in the construction documents.
2. Requests for substitution shall be submitted with sufficient in writing time for the architect to evaluate the requests without affecting the schedule or progress of the work, whether the proposed substitutions are accepted or rejected.
3. Submit separate requests for each product, and support each request with the following: reason for substitution, product identification, manufacturer's literature, samples (as applicable), and name and address of similar projects on which product has been used, and date of installation.

OPERATING INSTRUCTIONS & MAINTENANCE CONTRACTS.

The contractor shall, at his expense, prepare and provide the Owner all necessary warranties diagrams, operating instructions, owner's manuals and information required for the operation and maintenance of the mechanical and electrical systems.

CLEANING

- 1. For the purposes of this section, cleaning shall be interpreted as meaning the level of cleanliness generally provided by skilled cleaners using commercial quality building maintenance cleaners, equipment, and materials.
2. Upon completion of the work, and before turning over the project to the owner, general contractor shall follow, as a minimum, the following cleaning procedures unless instructed otherwise by the owner or the architect:
A. General
• Visually inspect all surfaces and remove all traces of soil, waste materials, smudges, and other foreign matter.
• Remove all traces of splashed materials from adjacent surfaces.
• Remove paint droppings, spots, stains, and grit from finished surfaces.
• In the event that stubborn stains are not removable by normal cleaning procedures, the architect may require additional cleaning procedures such as acid cleaning, sandblasting, etc. depending on the surface material in question.
• Should extra cleaning procedures be required, they shall be performed at no extra cost to the owner.
B. Glass: clean inside and outside.
C. Polished surfaces: to surfaces requiring routine application of buffed polish, apply the polish recommended by the manufacturer of the material being polished.
D. Finish flooring/carpet: vacuum clean all carpeting and clean all finish flooring material as recommended by the manufacturers. After cleaning, cover and/or protect all carpeting and finish flooring materials as required until the time of transferring the project to the owner.
E. Mechanical/Electrical/Plumbing
• Remove all construction dust and clean all supply and return grilles as required. replace all filters with new filters prior to transferring project to owner. See MEP general notes and/or specifications for additional cleaning requirements.
• Remove all construction dust and clean all light fixtures, lenses, recessed light fixtures trims and reflectors before transferring project to owner. See MEP general notes and/or specifications for additional cleaning requirements.
• Remove all construction dust and clean all plumbing fixtures and accessories before transferring project to owner. See MEP general notes and/or specifications for additional cleaning requirements.
• The project light fixtures and lamps are not to be used as a primary source of lighting during construction. any light fixtures used during construction should be thoroughly cleaned as indicated above, and it should be fitted with a new, unused lamp.
F. Final cleaning: schedule final cleaning with sufficient time to enable the owner to take over the project and prepare such for the use it was intended.

DIVISION 02-SITWORK

GENERAL

- A. General contractor shall verify existing locations of utilities, roof drains, H.V.A.C. equipment, etc. Prior to establishing contract sum and commencing construction.

SELECTIVE DEMOLITION:

- A. Provide complete wrecking of structures indicated and completely remove and dispose of all demolished materials. No explosives permitted. Control dust and noise; perform work in accordance with requirements of authorities having jurisdiction. No on-site sale of salvaged material permitted. Protect improvements on adjoining property. Disconnect and seal utilities; Comply with utility company requirements having jurisdiction.

DIVISION 03-CONCRETE

- A. All concrete work by general contractor must comply with the American Concrete Institute's specifications and guidelines.

4617 Montrose Blvd., Suite C.230
Houston, Texas 77006
Voice: 713.524.5858
Fax: 713.524.5868
studio@bravearchitecture.com
Contact: Silvana Micolich
smicolich@bravearchitecture.com



Consultants:

MEP:

Collaborative Engineering Group
8904 Fairbanks N. Houston Suite 201
Houston, TX 77064
T: 281.598.1170
F: 281.598.1130

SUNSET COFFEE

1019 Commerce St.
Houston, TX 77002

Ownership of Instruments of Service:
All reports, plans, specifications, computer files, field data, notes & other documents and instruments prepared by BRAVE / ARCHITECTURE as instruments of service shall remain the property of BRAVE / ARCHITECTURE. BRAVE / ARCHITECTURE shall retain all common law, statutory and other reserved rights, including the copyright thereto.

Issue:

2016.2.17 OWNER FINAL REVIEW
2016.2.23 PERMIT

B/A Project No.: 15137
Drawn By: MM
Checked By: SM
Date:
Scale: AS NOTED

SPECIFICATIONS

G.000.5

DIVISION 05—METALS

COLD—FORMED METAL FRAMING:

- A. Comply with American Iron and Steel Institute (AISI) "Specification for the design of cold formed steel structural members". Provide complete structural design of cold formed metal framing, bridging, bracing, and connections between members and to building structure, prepared by a registered structural engineer licensed in the state where the project is located and satisfactory to the architect. Design analysis does not include design of supporting building structure or cold formed metal framing effect on supporting structures. Design cold formed metal framing, bridging, bracing and all connections in conformance with the codes and standards specified and to resist dead loads, superimposed loads and wind loads, if any, required by the building code.
- B. Steel framing components for suspended and furred ceilings complying with ASTM C 645 and ASTM C 754.
- Wire ties: ASTM A 641, class 1 zinc coating, soft temper, 0.062 inch thick.
 - Hangers: ASTM A 641, class 1 zinc coating, soft temper, 0.162 inch diameter.
 - Carrying channels: cold-rolled steel, 1-1/2 inches deep.
 - Furring channels: steel rigid hat-shaped channels, 7/8 inch deep.
 - Direct-hung grid suspension system for interior ceilings.
- C. Steel framing for partitions complying with ASTM C 645.
- Studs and runners: in depth and 20 gauge minimum, unless otherwise noted, unless otherwise noted, use gold bond or u. s. gypsum metal studs.
 - Rigid hat-shaped furring channels: 7/8 inch and 0.0179 inch thick unless otherwise noted.
 - Furring brackets: adjustable serrated-arm type fabricated from corrosion-resistant steel sheet 0.0329 inch thick.
 - Hot dip galvanized coating complying with ASTM A 653, G40 for framing members attached to and within 10 feet of exterior walls.
 - All miscellaneous bolts, clips, anchors, angles, brackets, sleeves, fasteners, and other metal items as required.
- D. Where structural joists or studs are required, use 16 gauge c steel joists or studs by ClarkDietrich building systems or architect approved equal. Refer structural drawings.

MISCELLANEOUS METALS:

- A. Provide miscellaneous metal items at locations indicated or required; galvanized where exposed to damp, wet, or exterior conditions; prime painted where indicated to receive a painted finish.
- B. Items include, but are not limited to:
- Rough hardware, miscellaneous framing, bracing, supports, anchors, lintels, angles, clips, and plates.
- C. Comply with American welding society (AWS) for all welds. grind and smooth all welds in exposed locations.
- D. Provide complete structural design of miscellaneous metal items and connections between members and to building structure, prepared by a registered structural engineer licensed in the state where the project is located and satisfactory to the Architect.

DIVISION 06—CARPENTRY

ROUGH CARPENTRY

- A. Provide new lumber bearing grade and trademark of association under which it was produced. Lumber shall comply with PS-20 American softwood lumber standard, and with the applicable rules of inspection agencies certified by the American lumber standards committee's board of review.
- B. Nominal sizes are indicated except as shown by detail dimensions. Provide actual sizes as required by PS-20, for moisture content specified for each use.
- Provide seasoned lumber with 19 percent maximum moisture content at time of dressing and shipment for sizes 2 inches or less in nominal thickness.
 - Provide dressed lumber, S4S, unless otherwise indicated.
- C. For light framing, grounds, nailers, blocking and furring provide No. 1 common Douglas-fir, southern pine or cedar.
- D. All laminated or processed sheets shall be of quality and premium grade standards in accordance with the APA - The Engineered Wood Association, and shall comply with product standard PS-1, construction and industrial plywood.
- Plywood underlayment for stone, tile, and wood flooring: APA rated, underlayment grade, exterior plywood, 3/4 inch thick.
- E. Preservative treated materials: AWPA C2 lumber and AWPA C9 plywood, labeled by an inspection agency approved by ALSC's board of review. After treatment, kiln-dry lumber and plywood to 19 and 15 percent moisture content respectively. Treat indicated items and the following:
- Wood members in connection with vapor barriers, and waterproofing.
 - Concealed members in contact with masonry or concrete.
- F. Screws bolts and washers:
- American standard, ASTM A307 where exposed to moisture.
 - Provide wood screws complying with FF-S-111D, and of type and size best suited for the purpose.
- G. Nails:
- Provide necessary nail type as defined in ASTM F547, galvanized where exposed to moisture.
 - Provide type and size best suited for the purpose.
- H. Layout, cut, fit and erect framing for rough and finished work. Provide blocking, nailers, furring and other rough and finished materials as required to provide a complete installation. Brace, plumb and level members in true alignment and rigidly secure in place with sufficient nails, spikes, screws and bolts as necessary.
- I. Furnish and install all rough and finished plywood, furring supports, etc.
- J. Furnish and install all grounds or blocking required to receive wall or ceiling attached fixtures.
- K. Scheduled fire retardant pressure treated lumber shall be equal to Dricon fire retardant treated wood by Koppers Company, Inc. with mill stamp so indicating, pressure treat in accordance with standards or underwriter's flame spread rating not exceeding 25. No evidence of significant progressive combustion will show when tested for 30 minutes duration using standard test method for fire hazard classification of building materials (ASTM E 84, U. L. 723, NFPA 255.)

ARCHITECTURAL MILLWORK

A. GENERAL

- Provide all work necessary to complete all millwork as indicated on the architectural plan and schedule or otherwise shown or described in the contract documents.
- Woodwork quality standard: comply with applicable architectural woodwork quality standards of the Architectural Woodwork Institute (AWI), 2014 second edition, for PREMIUM grade.
- The millwork contractor shall examine the contract documents, the areas where custom millwork is to be installed and conditions under which the work will be executed. Notify the Architect in writing of any conditions

detrimental to the timely and proper completion of the work. Do not proceed with the work until unsatisfactory conditions have been corrected and are acceptable.

- The millwork contractor shall thoroughly investigate and resolve all access installation considerations, and shall coordinate same with the base building manager.
 - Verify dimensions before proceeding and obtain measurements at job site for work required to be accurately fitted to other construction. The millwork contractor shall be responsible for accuracy of such measurement and precise fitting and assembly of finished millwork.
 - Coordinate work with that of other trades affected by this installation. Give particular attention to timely furnishings of wood grounds, nailers and blocking so as not to delay job progress, and furnishing of electrical rough-in data to the electrical subcontractor.
 - All work shall be erected by skilled workmen, especially trained in this type of work by the manufacturer or his authorized representatives.
 - Special care shall be taken in the handling of the materials to avoid its being scratched or otherwise defaced during the course of installation, any materials showing evidence of such mishandling shall be replaced at the expense of the general contractor or millwork contractor.
 - Do not install units which have members that are warped, bowed, deformed or otherwise damaged or defaced. remove and replace such members as directed.
 - Submit shop drawings and samples including, but not limited to, the following:
 - Shop drawings indicating the location of each item, dimensioned plans and elevations, large-scale details, attachment devices, and other components.
 - Samples showing the full range of colors, textures, and patterns available for finish.
- B. MATERIALS
1. SOLID LUMBER STOCK
- Hardwood and solid stock for standing or running trim with transparent finish shall comply with AWI 100 lumber grading rules for premium grade. Provide lumber surfaced four sides (S4S) and worked to patterns shown or specified.
 - Provide premium grade solid wood in species as scheduled in the drawings, stained to match adjoining veneered surfaces.
 - Medium density fiberboard: not allowed.
 - Hardwood plywood and face veneers: HPVA HP-1.

C. INSTALLATION:

- Condition woodwork to prevailing conditions before installing.
- Install woodwork to comply with awi section 1700 for premium grade.
- Install woodwork level, plumb, true, and straight. Shim as required with concealed shims. install to a tolerance of 1/8 inch in 96 inches for level and plumb.
- Scribe and cut woodwork to fit adjoining work, seas cut surfaces, and repair damaged finish at cuts.
- Upon completion of the installation, remove all debris from the building created by work provided under this contract and leave all areas clean.
- Clean exposed finishes as recommended by the manufacturer or processor, using care to avoid abrasion of the finish.
- Protect all adjoining work from abrasion, soiling or damaging other work. repair or replace damaged work as directed without additional cost to the owner.

DIVISION 07—THERMAL AND MOISTURE PROTECTION

BUILDING INSULATION

A. GENERAL

- Provide all required building insulation and ensure that all penetrations, holes, gaps, joints, and openings through insulation materials are taped and sealed to ensure continuity of building envelope.
- B. Provide Batt or blanket thermal insulation produced by combining mineral fibers manufactured from glass fibers with thermosetting resins to comply with ASTM C 665 for type specified below; nominal density of 1.5 pcf; R-value of 3.1 per inch; manufacturer's standard lengths and widths as required to coordinate with spaces to be insulated; types as follows:
- Unfaced mineral-fiber blanket insulation: ASTM C 665, TYPE I (blankets without membrane facing); with maximum flame-spread and smoke-developed indices of 25 and 50, respectively; passing ASTM E 136 for combustion characteristics. products complying with the requirements include Owens Corning "thermal batts for metal frame construction", or CertainTeed Corp. "unfaced building insulation", or Johns-Manville "thermal-shield" Batts.
- C. Where insulation material will not be covered by subsequent construction materials, provide insulation complying class a requirements of ASTM C 665, with a flame spread rating of 25 (ASTM E 84); Owens Corning "flame spread 25 for special applications", CertainTeed Corp. "flame resistant foil" insulation, or Johns-Manville "Thermal HShield FSK".
- D. Thickness and thermal resistance (R-value): as indicated on the drawings.

THROUGH—PENETRATION FIRESTOP SYSTEMS

- A. Provide fire_smoke stop seals at all penetrations in rated construction in compliance with the systems indicated in the U.L. building materials directory for each construction condition. Acceptable manufacturers include the following or architect approved equal:
- Isolotek International.
 - 3M fire protection products.
 - The Rectorseal Corp.

JOINT SEALANTS

- A. Quality assurance: perform pre-construction joint sealant/substrate tests to confirm adhesion and compatibility. Perform pre-construction field tests to confirm technique required for appearance and adhesion.
- B. Acrylic_emulsion sealant: manufacturer's standard, one_part, non_sag, mildew_resistant, acrylic_emulsion sealant complying with ASTM C 834, formulated to be paintable and recommended for exposed applications on interior and protected exterior exposures involving joint movement of not more than plus or minus 7.5%
- subject to compliance with requirements, provide one (1) of the following, or architect approved equal:
 - Bostik "chem_calk 600".
 - Pecora Corp. "ac_20 + silicone".
 - Sonneborn building products div., Chemrex, Inc. "Sonolac".
 - Tremco, Inc. "Tremco acrylic latex 834".
 - Locations: all exposed and concealed interior locations.
 - Colors: as scheduled on drawings or selected by architect from manufacturer's available colors.
- C. Acoustical sealant: as specified in Division 09 Section "gypsum board assemblies".

- D. Mildew-resistant silicone rubber sealant: silicone rubber based, one-part, non-sag, elastomeric sealant, resistant to mildew; complying with ASTM C 920, type 8, and with resistance for mold growth; recommended by manufacturer for interior applications, including seal around both tubs, food service equipment and similar applications subjected to attack by mildew. Provide type recommended by manufacturer for porosity of joint surfaces.

- Subject to compliance with requirements, provide one (1) of the following, or architect approved equal:
 - DOW corning 786 mildew resistant silicone sealant; DOW corning corp.
 - Sanitary 1700; general electric.

DIVISION 08—DOORS AND GLAZING

A. GENERAL:

- Install all doors, frames, hardware, related parts, and materials as indicated on drawings and door and hardware schedules.
- Labeled doors: where required, provide U.L. labeled doors and frames per applicable state and local building codes.
- Fabricate and erect true, plumb and square as specified, detailed and per manufacturer's recommendations.
- Machine doors and panels for hardware at the place of manufacture, in accordance with hardware templates.
- Prime paint door faces, edges, and cutouts with one shop coat primer at the place of manufacture.
- Apply primer uniformly without runs, sags, or bare spots to a dry film thickness of 1 mil.
- See door schedule for specific information.
- General Contractor and millwork contractor shall submit full door, frame and hardware schedule for doors within their scope of work.

B. WOOD DOORS:

- Interior solid core doors for opaque finish: premium grade, for opaque finish.
- Interior stile and rail doors for opaque finish: custom doors to be manufactured according to door schedule and detailed drawings, premium grade. Glaze doors at factory.
- Align and fit doors in frames with uniform 1/8 inch clearances and bevels at jambs, heads, and meeting stiles and 1/8 inch at bottom.
- repair, refinish or replace doors damaged during installation as directed by architect.

C. FINISH HARDWARE:

- Refer to the hardware schedule.
- Mount hardware in locations recommended by the door and hardware institute, unless otherwise indicated.
- Install each hardware item in compliance with the manufacturer's instruction and recommendations. Wherever cutting and fitting is required to install hardware onto or into surfaces which are later to be painted or finished in another way, coordinate removal, storage and reinstallation or application of surface protections with finishing work in the Division-9 section. Do not install surface-mounted items until finishes have been completed on the substrate.
- Keying: supplier will meet with owner to finalize keying requirements and obtain final instructions in writing. Furnish 3 keys for each lock.
- Adjust and clean each operating item of hardware and each door, to ensure proper operation or function of every unit. replace units which cannot be adjusted to operate freely and smoothly as intended for the application made. Clean adjacent surfaces soiled by hardware installation.

D. ACCESS PANELS:

- General Contractor shall supply and install access panels as shown on these documents through inaccessible ceilings or walls as required by code, Landlord or per functional requirements to allow access for all equipment above the ceiling requiring periodic maintenance or inspection.
- If field conditions do not allow the installation of access panels as shown in these construction documents, G.C is to contact architect for instructions before proceeding.

E. GLASS:

- General: comply with applicable standards for architectural glazing materials (16 CFR 1201) issued by consumer products safety commission, with all amendments thereto.
- Comply with "glazing manual" by Glass Association of North America (GANA), except as shown and specified otherwise or where more stringent requirements are recommended in writing by the glass manufacturer.
- Primary glass standard: ASTM C 1036.
- Heat-treated glass standard: ASTM C 1048.
- Provide lites of the following glass types, heat strengthened or fully tempered where recommended by the glass manufacturer to withstand thermal stress, other conditions specified, and building code. submit supporting documentation from glass manufacturer as required. each glass type shall be the manufactured and fabricated product of one manufacturer.
 - Clear float glass: not allowed.
 - Clear tempered glass, condition A, type I, class 1, quality Q3, kind FT (fully tempered), 1/4 inch thick.

DIVISION 09—FINISHES

GYPSUM BOARD ASSEMBLIES:

A. GENERAL

- Furnish and install all gypsum drywall and systems complete with partitions framing, ceiling suspension systems and related accessories, parts, materials, etc. as shown on drawings and specified. Install all materials per ASTM C840 and manufacturer's specifications and recommendations.
- Gypsum drywall: U.S. gypsum 5/8 inch thick fire code Sheetrock (type x) panels of standard quality. Use 5/8 inch thick water resistant fire code gypsum board where specifically noted.
- Cementitious backerboard: backerboard as manufactured by Bonsal , Util-A-Crete, with wrapped, tapered edge; size as indicated on drawings.
- Fasteners: drywall screws of proper size and type per manufacturer's recommendations.
- Metal accessories: U.S. Gypsum or gold bond system of components. Install metal reglets as indicated on drawings by Pittcon Industries according to manufacturer's instructions.
- Fire rated construction: wherever a fire resistance classification is scheduled or shown, provide materials, accessories and application procedures which have been listed by UL or tested according to ASTM E 119 for type of construction shown.
- All stud systems shall be designed and installed for deflection not to exceed 1/240 under uniform loading of 5 pounds per square foot over the entire area of partition.
- Additional studs: provide additional studs to support inside corners at partition intersections and corners, and to support outside corners, partition terminations, both sides of control joints and adjacent to all openings.

- Use full length studs between runner tracks.
- Typical stud spacing shall be 16 inches o.c. start typical spacing 6 inches either side of door or cased opening reinforcing.
- Joint treatment: U.S. Gypsum or gold bond system of compounds and perforated tape.
- FINISHING
 - Walls shall be given a smooth finish.
 - Ceilings and soffits shall be given a smooth finish.
 - Corner bead shall be applied to all external angles in strict accordance with the manufacturer's directions. Install casing beads at all edges of drywall work except where termination is covered by other finish. Casing beads shall be mitered at corners, installed neatly, screwed in place, and finished with compound.
 - Joints between boards shall be reinforced with tape except where control joints are required. Tape field joints, interior corner joints and wall to ceiling joints. Fill joints with joint filling compound and embed tape therein. Cover tape with bedding compound and feather edges. Allow to dry.
 - Cover taped and filled joints and filled screw head depressions with topping compound applied in coat.
 - Sand joint and screw head areas lightly between coats and after the final coat so that a smooth level surface is produced with the paper surface of the wallboard free of scuffing.
 - Retouch marked blemishes after painter applies primer coat.

B. CEILING SYSTEMS

- Furnish and install ceiling systems complete with suspension system and related accessories as shown on drawings and as specified.
- Suspension systems shall be adequate to support fixtures, ceiling grilles, diffusers and other normal accessories. Provide system components from single manufacturer. 4"-0" maximum between supports and fasten to structure above.
- Install ceiling and suspension systems in strict accordance with manufacturer's recommendations. Finish ceiling shall be level.
- MATERIALS AND FINISHES
 - Refer to drawings for location of specified materials and finishes.
 - G.W.B CEILING: 5/8 inch type x gypsum wall board suspended on 16 gauge cold rolled steel 1-1/2 inch main runner channels at 48 inches O.C. and 20 gauge 7/8 inch rolled formed hot shaped metal furring channels at 16 inches O.C. suspend with No. 12 gauge suspension wires. General Contractor to provide access panels or knock-out panels as required. Owner's representative to approve location and necessity of panels.
 - Subject to compliance with requirements, provide one (1) of the following, or architect approved equal:
 - Sheetrock acoustical sealant; United States Gypsum Co.
 - AC-20 acoustical sealant; Pecora Corp.
 - Locations: concealed gypsum drywall partitions perimeter and penetrations.
 - Sound attenuation blankets: ASTM C 665, TYPE I; Thermafiber sound attenuation blanket; United States Gypsum, or architect approved equal.

4617 Montrose Blvd., Suite C.230
Houston, Texas 77006
Voice: 713.524.5858
Fax: 713.524.5868
studio@bravearchitecture.com
Contact: Silvana Micolich
smicolich@bravearchitecture.com

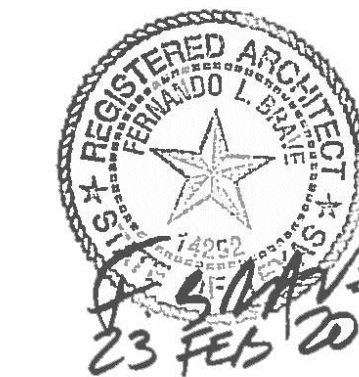

Consultants:

MEP:

Collaborative Engineering Group
8904 Fairbanks N. Houston Suite 201
Houston, TX 77064
T: 281.598.1170
F: 281.598.1130

SUNSET COFFEE

1019 Commerce St.
Houston, TX 77002

Ownership of Instruments of Service:
All reports, plans, specifications, computer files, field data, notes & other documents and instruments prepared by BRAVE / ARCHITECTURE as instruments of service shall remain the property of BRAVE / ARCHITECTURE. BRAVE / ARCHITECTURE shall retain all common law, statutory and other reserved rights, including the copyright thereto.

Issue:

2016.2.17 OWNER FINAL REVIEW
2016.2.23 PERMIT

B/A Project No.: 15137
Drawn By: MM
Checked By: SM
Date:
Scale: AS NOTED

SPECIFICATIONS

G.000.6

Protect installed work from damage until final acceptance by the owner/tenant.

TILING:

A. Porcelain tile, ceramic mosaic tile, paver tile, glazed wall tile.

B. Materials

1. Manufacturers: tile

Refer to manufacturers and contact information provided in drawings.

2. Manufacturers: tile—setting and — grouting materials

- American Olean Tile Company.
- Dal—Tile corporation.
- DAP, Inc.
- Laticrete International, Inc.
- Southern Grouts & Mortars, Inc.

C. ANSI ceramic tile standard: standard grade requirements of ANSI A137.1.

D. Colors, textures, and patterns: for tile, grout, and other products as selected by architect and in finish schedule.

E. Unglazed ceramic mosaic tile: modular, factory—mounted flat tile.

F. Glazed ceramic mosaic tile: modular, factory—mounted flat tile.

G. Unglazed quarry tile: square—edged flat tile.

H. Unglazed paver tile: flat tile:

- latex—portland cement mortared and grouted paver tile, precoated with temporary protective coating.

I. Glazed paver tile: flat tile:

J. Glazed wall tile: flat tile modular size, cushion edge.

1. mounting: pregrouted sheets of tiles factory assembled and grouted with manufacturer's standard silicone rubber complying with ANSI A118.6.

K. Trim units to match adjoining tile, thresholds to match tile, but not more than 1/2 inch above adjoining finished floor, beveled edge.

L. Waterproofing for thin—set tile installations: ANSI A118.10.

M. Setting Materials:

- Portland Cement mortar installation materials: ANSI A108.1A A. latex additive (water emulsion) for use with job—mixed portland cement and aggregate mortar bed.
- Dry—set portland cement mortar: ANSI A118.1.
- latex—portland cement mortar: ANSI A118.4.
- Water—cleanable, tile—setting epoxy adhesive: ANSI A118.3.

N. Grouting materials. As follows:

- Sand—portland cement grout: ANSI A108.10, composed of white or gray cement and white or colored aggregate, or
- Latex—portland cement grout: ANSI A118.6 for materials described in section h—2.4.
- Product capable of resisting continuous and intermittent exposure to temperatures of up to 140 degrees F and 212 degrees F, respectively, as certified by mortar manufacturer for intended use.

O. Elastomeric sealants:

- One—part, mildew—resistant silicone sealant: ASTM C 920; type S; grade ns; class 25; uses NT, G, A, and, O; formulated with fungicide.

P. Cementitious backer units: per ANSI A118.9, of thickness and width required, and in maximum lengths to avoid end—to—end butt joints.

Q. Miscellaneous materials. As follows:

- Trowelable underlayment and patching compounds: latex—modified, portland—cement based for installations as required.
- Metal edge strips: white—zinc—alloy terrazzo strips, 1/8 inch wide at top edge with integral provision for anchorage to mortar bed or substrate.

R. Execution

1. Provide concrete substrates for tile floors installed with dry—set or latex—portland cement mortars that comply with flatness tolerances specified in referenced ANSI A108.

- Use trowelable leveling and patching compounds per tile—setting material manufacturer's written instructions to fill cracks, holes, and depressions.
- Remove protrusions, bumps, and ridges by sanding or grinding.

2. Blending: for tile exhibiting color variations within the ranges, verify that tile has been blended in the factory and packaged so tile units taken from one package show the same range in colors as those taken from other packages and match approved samples.

a. Comply with parts of ANSI A108 series of tile installation standards that apply to types of setting and grouting materials and to methods indicated.

b. TCA Installation guidelines: comply with TCA installation methods.

c. Extend tile work into recesses and under or behind equipment and fixtures to form a complete covering without interruptions, unless otherwise indicated. Terminate work neatly at obstructions, edges, and corners without disrupting pattern or joint alignments.

d. Accurately form intersections and returns. Perform cutting and drilling of tile without marring visible surfaces. Carefully grind cut edges of tile abutting trim, finish, or built—in items for straight aligned joints. fit tile closely to electrical outlets, piping, fixtures, and other penetrations so plates, collars, or covers overlap tile.

e. Jointing pattern: Refer to elevations. Lay tile in grid pattern, unless otherwise indicated, align joints where adjoining tiles on floor, base, walls, and trim are the same size. provide uniform joint widths, unless otherwise indicated.

f. expansion joints: locate expansion joints and other sealant—filled joints.

g. install waterproofing to produce a waterproof membrane of uniform thickness bonded securely to substrate.

h. floor tile installation: install tile to comply with referencing TCA installation methods and ANSI A108 series of tile installation standards.

i. Wall tile installation: per referenced TCA installation methods and ANSI setting—bed standards.

1) joint widths: install tile on walls with uniform 1/16 inch joint widths.

RESILIENT BASE:

A. Material: vinyl base, 0.125 inch gauge by high as scheduled. style shall be coved.

B. Colors: as scheduled.

C. Adhesive: as recommended by the resilient base manufacturer.

D. Install base in as long lengths as practicable. Tightly bond base to backing throughout the length of each piece with continuous contact of horizontal and vertical surfaces. Remove excess adhesive or other surface blemishes from tile and base, using neutral type cleaners as recommended by the manufacturer.

PAINTING:

A. Painting and finishing colors: as scheduled, where not scheduled, provide colors as selected by the architect. Colors shall not be limited to manufacturer's standard colors.

B. All paints, varnishes, stains, paste fillers, thinners, colors and similar materials shall be delivered in original containers with seals unbroken and labels intact.

C. Paints, enamels and stains: provide the best quality grade products of following manufacturer: provide samples to owner.

1. Benjamin Moore

2. Interpon

D. All materials, such as thinners, dryers etc. shall be of same brand as that of painting materials or of brand recommended by the manufacturer of the brand of painting materials.

E. All materials shall be used as delivered, from the cans, without thinning or adulteration, whenever possible to do so.

F. All primers and undercoats shall be tinted slightly lighter than shade of finish coat

G. Interior painting:

1. Ferrous metal surfaces (including existing exposed structure):

- One (1) coat Benjamin Moore retard rust inhibitive primer
- Two (2) coats of final finish.

2. Existing metal surfaces:

- one (1) coat Benjamin Moore speedy primer sealer.
- Spot prime damaged areas of existing surfaces with Benjamin Moore retard rust inhibitive primer.
- Interior of ducts connection to exhaust or return of grilles, registers, or diffusers shall be given two (2) coats of Benjamin Moore galvanized metal primer.

3. Wood (painted): one (1) coat Benjamin Moore "alkyd enamel underbody primer", and two (2) coats of final finish.

4. System at locations scheduled.

5. Eggshell finish: one (1) coat Benjamin Moore "latex underbody primer", and two (2) coats of final finish.

6. Semi—gloss finish: one (1) coat Benjamin Moore "latex underbody primer", and two (2) coats of final semi—gloss finish.

7. Interior doors and frames to receive one (1) coat Benjamin Moore "latex underbody primer" and two (2) coats of final semi—gloss finish.

8. Existing painted walls and ceilings: spot prime repaired areas, and apply finish systems of the types and number of coats specified for drywall surfaces.

H. Condition of surfaces: remove all loose dirt, oil, grease, rust, dust paint and other foreign material before beginning painting and finishing. Remove hardware, hardware accessories, machine surface, plates, lighting fixtures and similar items in place and not to be painted, or provide surface protection prior to surface preparation and painting operations. Following completion of painting of each space or area, reinstall removed items. Repair defects to new and existing surfaces to avoid finish failures or the reoccurrence of previous failures. Cut out scratches, cracks and abrasions in new and existing surfaces, fill with approved material, bring flush with adjoining surface and finish to match adjacent surface texture. patched areas shall not be visible in the finished work. Seal before application of prime coat.

I. Existing painted surfaces: remove all loose and scaling paint. Make certain all paint remaining is adhered well to the surface. Remove all grease oil, and other surface contaminants which would affect adhesion of new paint finish. Sand surfaces for proper paint adhesion, and to remove glossy areas in the existing paint finish. Sand rough edges of bare areas to feather edge at adjacent sound point. Painting and finishing of patched or damaged surfaces occurring outside the contract limit area, shall be contained to the nearest change in plane or interruption of surface.

J. Materials preparation: mix and prepare painting materials in accordance with manufacturer's directions. stir materials before and during application to produce a mixture of uniform density do not stir surface film into material.

K. Application:

9. General: apply paint in accordance with manufacturer's directions. use applications and techniques best suited for substrate and type of material being applied. apply additional coats when undercoats, stains or other conditions show through final coat of paint, until paint film is a uniform finish, color and appearance. paint surfaces behind movable equipment and furniture same as similar exposed surface. sand lightly between each succeeding enamel coat. allow sufficient time between successive coatings to permit proper drying. recoat primed and sealed surfaces where there is evidence of suction spots or surface defects due to insufficient priming or sealing.

10. Completed work: match approved samples for color, texture and coverage. cloudiness, spotting, holidays, laps, brush marks, runs, sags, ropiness or other surface imperfections will not be acceptable. remove, refinish, and/or repair work not in compliance with specified requirements.

11. Cleanup and protection: during progress of work, remove from site discarded paint materials, rubbish cans, and rags at end of each work day. upon completion of painting work, clean window glass and other paint—spattered surfaces, protect work of other trades, whether to be painted or not, against damage by painting and finishing work. Correct any damage as acceptable to owner. provide "wet paint" signs as required to protect newly—painted finishes. at completion of work of other trades, touch—up and restore all damaged or unsealed areas in first coat, to assure a finish coat with no burn—through or other defaced painted surfaces.

DIVISION 15—MECHANICAL

A. See engineering drawings for specifications.

DIVISION 16—ELECTRICAL

A. See architectural and engineering drawings for specifications.



- D1.01 Remove existing partition/wall. Remove existing finish construction back to existing base building structure. Clean and prepare to receive new construction.
- D1.03 Contractor to maintain structural integrity of building.
- D1.05 Remove and relocate door, hardware and frame where indicated
- D1.12 Remove exit sign to remain.
- D1.13 Remove light fixtures
- D1.14 Remove shelving
- D1.15 Remove and relocate fire extinguisher
- D1.15 Existing column to remain. All existing structure to remain.
- D1.16 Existing storefront to remain.
- D1.17 Existing door and hardware to remain
- D1.18 Existing window to remain.
- D1.25 Existing balcony and railing to remain.
- D1.26 Existing concrete slab to remain.
- D1.27 Existing restrooms to remain.
- D1.28 Existing janitor room to remain.
- D1.29 Existing elevator to remain.
- D1.30 Existing exterior walkway to remain.
- D1.31 Existing light fixture to remain.
- D1.32 Existing stairs to remain.
- 1.03 Scheduled door
- 1.04 Scheduled partition
- 1.05 Custom Millwork, Re: Millwork
- 1.17 Scheduled light fixture: Re: Electrical
- 1.23 Fire extinguisher
- 1.32 Custom glass display, Re: Millwork
- 1.33 Custom rope "screen". Rope by owner, installed by GC. Re: Millwork
- 1.34 Fixed panel with in-counter adjustable cup dispensers. Dispense-Rite ADJ-2
- 1.35 Furniture - OF01
- 1.36 Custom Wall Shelf. Re: Millwork
- 1.40 S.S. sink. Re: MEP
- 1.45 S.S. Hand sink. Re: MEP
- 1.48 Existing Structure
- 1.49 Existing three compartment sink
- 1.50 Shelving system.
- 1.51 Steel bracket
- 1.52 Cup dispenser, Dispense Rite ADJ-2 (typ.) S.S.
- 1.53 Knock Chute, S.S. 6" x 5.5" x 4" Espresso Supply Inc.
- 1.54 6" S.S. grommet
- 2.01 2x6 Wood slot ceiling @ 10'-0" A.F.F.
- 2.02 Gyp. board ceiling @ 8'-6" A.F.F.
- 2.03 Salvaged rope installation
- 2.04 Slot wood ceiling hung with Unistrut @ 48" O.C. max.
- 2.05 Stained wood shelves with black steel brackets
- 2.06 Stained wood shelves with internal steel support

- GD1. Visit the site to become familiar with the scope of work and to field verify existing conditions prior to bidding this project. Report any and all discrepancies or ambiguous items to the architect prior to bidding for clarification.
- GD2. Note that there are demolition notes on the Civil and MEP plans, as well. Provide all other demolition work required by construction sequencing and means and methods to install the new and remodeled work shown, whether such related and necessary demolition work is specifically noted on these drawings or not.
- GD3. Coordinate demolition work with floor plans. Refer to sections and details for frame types and details at new openings in existing walls.
- GD4. Refer to Civil and MEP drawings for additional demolition and alteration notes.
- GD5. Prior to start of demolition, secure from the owner a list of additional existing building components to be salvaged such that salvaged components are delivered to the owner in their existing condition.
- GD6. The Owner has first rights of salvage of all fixtures, equipment and building materials removed as part of the demolition and not reused in the new construction. Remove all other debris and waste from the site and dispose of properly, in accordance with any applicable federal, state and local regulations.
- GD7. Refer to Index Sheet G.001 and G.002 for typical graphic symbols and abbreviation index.
- GD8. Refer to demolition photographs for additional information and guidelines. Photographs are for reference ONLY unless otherwise noted. All photographs are included for Contractor's reference ONLY unless noted otherwise. The photographs are to be used in conjunction with all drawings, both plan and elevations. Information presented on all drawings supercedes any information noted on photographs. It is not the Architect's intent to present the entire scope of work or all built conditions by the use of photographs. It is the responsibility of the Contractor to verify the scope of work and ALL build conditions in the field prior to start of work.
- GD9. Refer to specifications Division 1 for further demolition standards and requirements.
- GD10. Prior to cutting or altering any opening in an existing wall, footing or roof deck provide shoring, bracing and supports as required to maintain the structural integrity of the building/structure.
- GD11. Prior to removing any existing bearing wall provide shoring, bracing and supports required to maintain the structural integrity of the building/structure.
- GD12. Provide materials for cutting and patching which will result in equal-or-better work than what was removed. Surface to match existing, U.NO.
- GD13. Existing construction that is being removed shall be removed carefully so as not to damage any existing construction that is to remain. All surfaces surrounding objects being removed are to be repaired and patched (in a rectangular pattern) to match existing conditions and made ready to receive any new finishes where applicable.
- GD14. Plumbing lines that are to be removed shall be removed completely or be capped as closed to point of entry in floor or wall as possible, if removal is not possible. Patch floors and walls to match existing conditions.
- GD15. Where existing flooring, ceilings or wall finishes are to be removed and replaced with new finishes the surfaces to remain shall be stripped clean of all existing finishes and made ready to receive new finishes.
- GD16. Floor finishes being replaced shall be completely removed, and the floor cleaned and properly prepared prior to installation of new finish material. Inspect all floors that receive new finishes to assess existing conditions prior to commencement of construction. Patch, fill and strip floor as required, to provide a smooth, durable surface free of burrs and adhesive and suitable for application of new finish material. Under cut doors as required to accommodate new floor finishes.
- GD17. Where new concrete topping is being poured over existing concrete slab: bush hammer existing concrete finish for better bond.
- GD18. Where existing door openings are to be sealed: remove frame and patch wall with the same material and finish as the existing construction. New and existing wall shall align.
- GD19. Where light fixtures are being removed or replaced, ceiling surfaces shall be cleaned, repaired and patched to match the adjacent surfaces prior to installation of new light fixtures.
- GD20. Where door frames are to remain, repair frame - fill hinge pocket and all holes in frame to create finished case opening. Clean, sand smooth and paint frame to match existing door frames.
- GD21. Where wall mounted urinal and water closets are to be removed, remove flush valves and prepare surfaces to be sloped and to drain to existing floor drain. Prep surfaces to receive new finish.
- GD22. Remove floor slab as required for new restroom fixtures. Patch and repair slab to match existing.

NOT USED

16 KEY NOTES 5

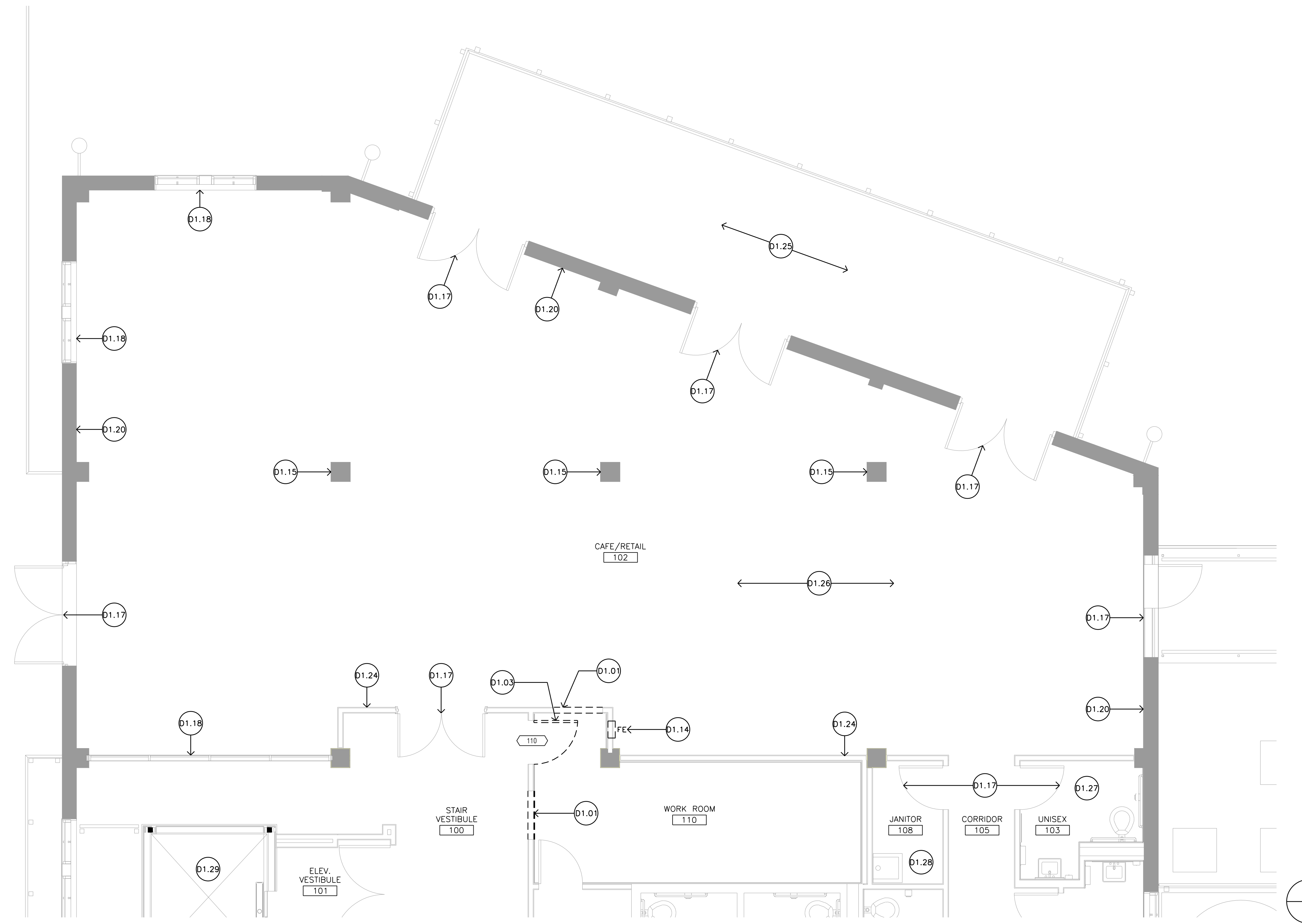

DEMOLITION FLOOR PLAN 1/4" = 1'-0" 5

GENERAL NOTES 1

Consultants:

MEP:

Collaborative Engineering Group
8904 Fairbanks N. Houston Suite 201
Houston, TX 77064
T: 281.598.1170
F: 281.598.1130

SUNSET COFFEE

1019 Commerce St.
Houston, TX 77002

Ownership of Instruments of Service:
All reports, plans, specifications, computer files, field data, notes & other documents and instruments prepared by BRAVE / ARCHITECTURE as instruments of service shall remain the property of BRAVE / ARCHITECTURE. BRAVE / ARCHITECTURE shall retain all common law, statutory and other reserved rights, including the copyright thereto.

ISSUE:

2016.2.17 OWNER FINAL REVIEW
2016.2.23 PERMIT

B/A Project No.: 15137
Drawn By: MM
Checked By: SM
Date:
Scale: AS NOTED

DEMOLITION FLOOR PLAN

D.101



Consultants:

MEP:

Collaborative Engineering Group
8904 Fairbanks N. Houston Suite 201
Houston, TX 77064
T: 281.598.1170
F: 281.598.1130

SUNSET COFFEE

1019 Commerce St.
Houston, TX 77002

Ownership of Instruments of Service:
All reports, plans, specifications, computer files, field data, notes & other documents and instruments prepared by BRAVE / ARCHITECTURE as instruments of service shall remain the property of BRAVE / ARCHITECTURE. BRAVE / ARCHITECTURE shall retain all common law, statutory and other reserved rights, including the copyright thereto.

Issue:

2016.2.17 OWNER FINAL REVIEW
2016.2.23 PERMIT

B/A Project No.: 15137
Drawn By: MM
Checked By: SM
Date:
Scale: AS NOTED

DEMOLITION REFLECTED CEILING PLAN

D.201

- D1.01 Remove existing partition/wall. Remove existing finish construction back to existing base building structure. Clean and prepare to receive new construction. Contractor to maintain structural integrity of building. Remove and relocate door, hardware and frame where indicated
- D1.03 Existing exit sign to remain.
- D1.05 Existing light fixtures
- D1.12 Remove shelving
- D1.13 Remove and relocate fire extinguisher
- D1.14 Existing column to remain. All existing structure to remain.
- D1.15 Existing storefront to remain.
- D1.16 Existing door and hardware to remain
- D1.17 Existing window to remain.
- D1.18 Existing balcony and railing to remain.
- D1.25 Existing concrete slab to remain.
- D1.26 Existing restrooms to remain.
- D1.27 Existing janitor room to remain.
- D1.28 Existing elevator to remain.
- D1.29 Existing exterior walkway to remain.
- D1.30 Existing light fixture to remain.
- D1.31 Existing stairs to remain.
- D1.32 Scheduled door
- 1.03 Scheduled partition
- 1.04 Custom Millwork, Re: Millwork
- 1.17 Scheduled light fixture: Re: Electrical
- 1.23 Fire extinguisher
- 1.32 Custom glass display, Re: Millwork
- 1.33 Custom rope "screen". Rope by owner, installed by GC. Re: Millwork
- 1.34 Fixed panel with in-counter adjustable cup dispensers. Dispense-Rite ADJ-2
- 1.35 Furniture - OFOI
- 1.36 Custom Wall Shelf, Re: Millwork
- 1.40 S.S. sink, Re: MEP
- 1.45 S.S. Hand sink, Re: MEP
- 1.48 Existing Structure
- 1.49 Existing three compartment sink
- 1.50 Shelving system.
- 1.51 Steel bracket
- 1.52 Cup dispenser, Dispense Rite ADJ-2 (typ.) S.S.
- 1.53 Knock Chute, S.S. 6" x 5.5" x 4" Espresso Supply Inc.
- 1.54 6" S.S. grommet
- 2.01 2x6 Wood slat ceiling @ 10'-0" A.F.F.
- 2.02 Gyp. board ceiling @ 8'-6" A.F.F.
- 2.03 Salvaged rope installation
- 2.04 Slot wood ceiling hung with Unistrut @ 48" O.C. max.
- 2.05 Stained wood shelves with black steel brackets
- 2.06 Stained wood shelves with internal steel support

NOT USED

16 KEY NOTES

8

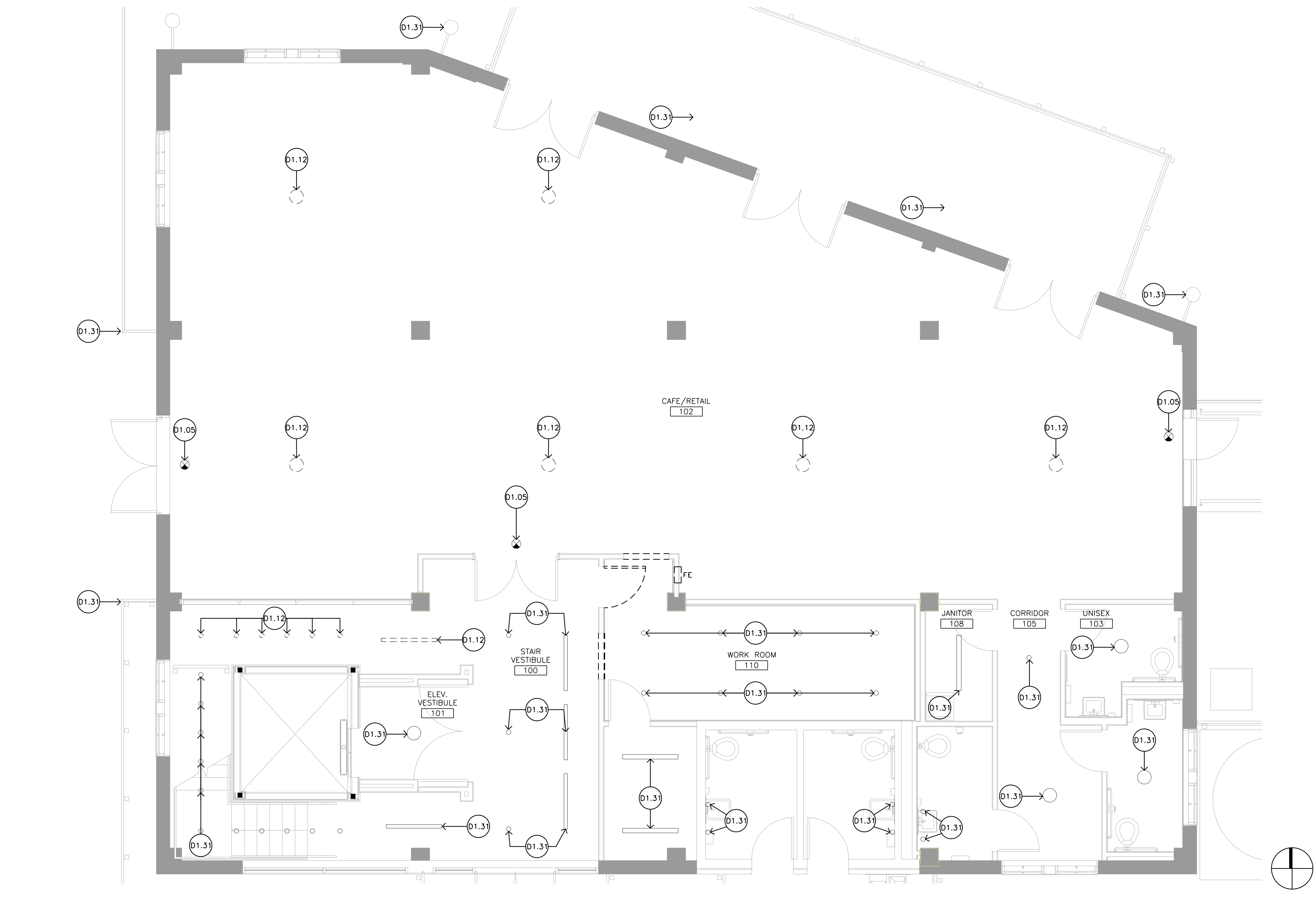

DEMOLITION REFLECTED CEILING PLAN

1/4" = 1'-0" 5 GENERAL NOTES

1



Consultants:

MEP:

Collaborative Engineering Group
8904 Fairbanks N. Houston Suite 201
Houston, TX 77064
T: 281.598.1170
F: 281.598.1130

SUNSET COFFEE

1019 Commerce St.
Houston, TX 77002

Ownership of Instruments of Service:
All reports, plans, specifications, computer files, field data, notes & other documents and instruments prepared by BRAVE / ARCHITECTURE as instruments of service shall remain the property of BRAVE / ARCHITECTURE. BRAVE / ARCHITECTURE shall retain all common law, statutory and other reserved rights, including the copyright thereto.

Issue:
2016.2.17 OWNER FINAL REVIEW
2016.2.23 PERMIT
2016.5.4 PERMIT COMMENTS

B/A Project No.: 15137
Drawn By: MM
Checked By: SM
Date:
Scale: AS NOTED

FLOOR PLAN

A.101

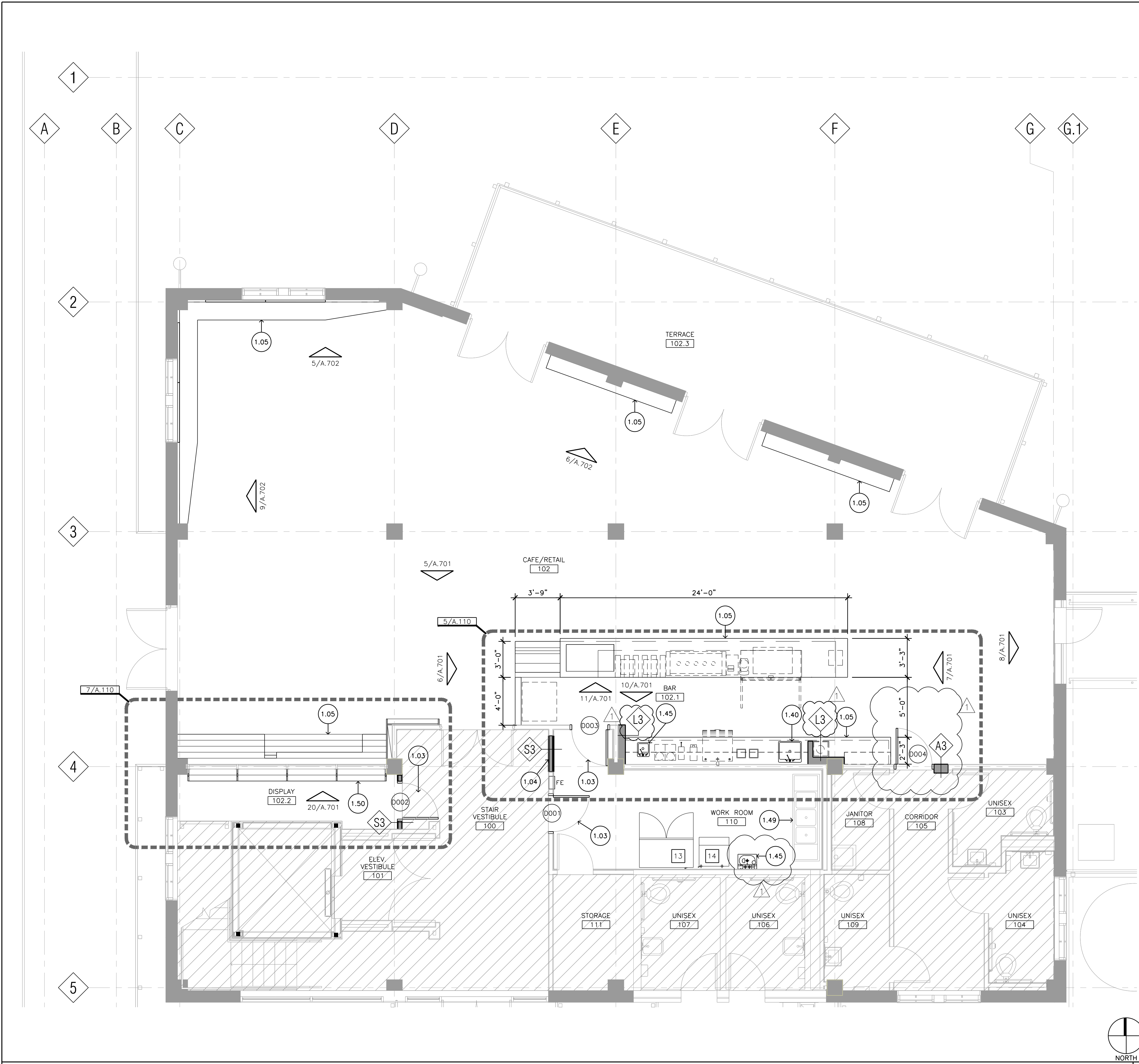

- D1.01 Remove existing partition/wall. Remove existing finish construction back to existing base building structure. Clean and prepare to receive new construction. Contractor to maintain structural integrity of building.
- D1.03 Existing exit sign to remain.
- D1.05 Existing door and hardware to remain
- D1.12 Existing window to remain.
- D1.13 Remove shelving
- D1.14 Remove and relocate fire extinguisher
- D1.15 Existing column to remain. All existing structure to remain.
- D1.16 Existing storefront to remain.
- D1.17 Existing door and hardware to remain
- D1.18 Existing window to remain.
- D1.25 Existing balcony and railing to remain.
- D1.26 Existing concrete slab to remain.
- D1.27 Existing restrooms to remain.
- D1.28 Existing janitor room to remain.
- D1.29 Existing elevator to remain.
- D1.30 Existing exterior walkway to remain.
- D1.31 Existing light fixture to remain.
- D1.32 Existing stairs to remain.
- 1.03 Scheduled door
- 1.04 Scheduled partition
- 1.05 Custom Millwork. Re: Millwork
- 1.17 Scheduled light fixture: Re: Electrical
- 1.23 Fire extinguisher
- 1.32 Custom glass display. Re: Millwork
- 1.33 Custom rope "screen". Rope by owner, installed by GC. Re: Millwork
- 1.34 Fixed panel with in-counter adjustable cup dispensers. Dispense-Rite ADJ-2
- 1.35 Furniture - OFOI
- 1.36 Custom Wall Shelf. Re: Millwork
- 1.40 S.S. sink. Re: MEP
- 1.45 S.S. Hand sink. Re: MEP
- 1.48 Existing Structure
- 1.49 Existing three compartment sink
- 1.50 Shelving system.
- 1.51 Steel bracket
- 1.52 Cup dispenser, Dispense Rite ADJ-2 (typ.) S.S.
- 1.53 Knock Chute, S.S. 6" x 5.5" x 4" Espresso Supply Inc.
- 1.54 6" S.S. grommet
- 2.01 2x6 Wood slot ceiling @ 10'-0" A.F.F.
- 2.02 Cyp. board ceiling @ 8'-6" A.F.F.
- 2.03 Salvaged rope installation
- 2.04 Slot wood ceiling hung with Unistrut @ 48" O.C. max.
- 2.05 Stained wood shelves with black steel brackets
- 2.06 Stained wood shelves with internal steel support

KEY NOTES 3

Equipment list below is provided and installed by owner's food and beverage consultant. Re: MEP for details

- 1 Beverage Case
- 2 Coffee Registers
- 3 "Poursteady" Coffee Machine. See also water boiler requirements
- 4 "Stroda" Espresso Machine. See also water pump and water filtration softener requirements
- 5 "Mazzer" Grinder
- 6 Bar Register
- 7 "Bunn" Hot Water Tower
- 8 "Bunn" Grinder
- 9 Blender
- 10 Brewing System
- 11 Undercounter Refrigerator
- 12 Undercounter Ice bin
- 13 Refrigerator
- 14 Ice Maker

Accessories below to be provided by owner's food and beverage consultant.

- 15 23 gallon wall hugger trash can (20x12x30 inches)
- 16 Open top, no cover trash can by Bobrick (B-2280)

LEGEND 2

- FP1. Refer to General sheets for typical graphic, symbols, abbreviation index, and "Master Keynote" list.
- FP2. All horizontal dimensions are provided on plans, and all vertical dimensions are provided on elevations and/or sections unless otherwise noted.
- FP3. Overall plan indicates exterior building dimensions, room numbers and names, door designations, window designations, exterior elevation designations, exterior plan designations, sign designations, and building section designations. All other plan information is indicated on referenced enlarged plans.
- FP4. Enlarged plans indicate interior building dimensions to face of partition material, interior plan detail designations, interior elevation designations, partition type designations, finish designations, and general building material.
- FP5. All dimensions are to be tied to a column line. Contractor will immediately report any omission of dimensions not tied to a column to the Architect prior to start of construction.
- FP6. Coordinate all MEP access panels not shown on architectural construction documents with Architect prior to installation.
- FP7. Provide adequate blocking as required at every location where millwork, wall light fixtures, TV brackets, plumbing fixtures, etc., are to be mounted.
- FP8. There are items shown, i.e. outlets, switches, thermostats, on the MEP drawings that are not drawn on the architectural plans. Contractor to coordinate and mount all MEP items per Architectural sheet A.730 unless noted otherwise.
- FP9. All equipment / areas labeled "ADA" are to be accessible. Refer to Texas Accessibility Guidelines and Standard Mounting Locations & Toilet Room Configuration.
- FP10. All wood blocking to be Fire Resistant

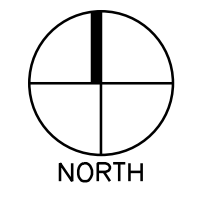
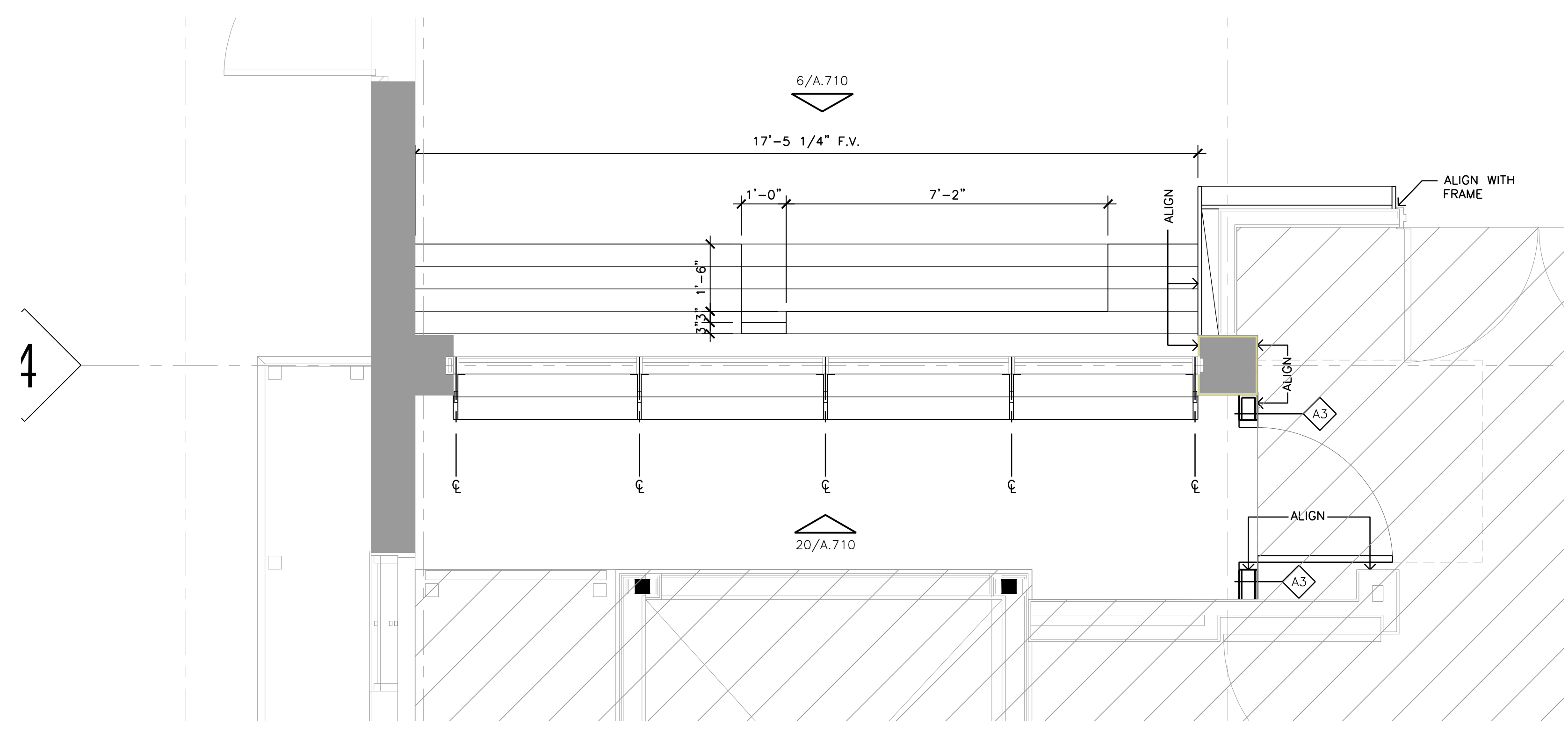

DISPLAY ENLARGED FLOOR PLAN

1/2" = 1'-0" 7

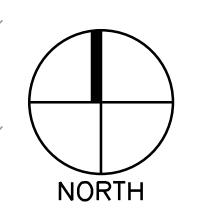
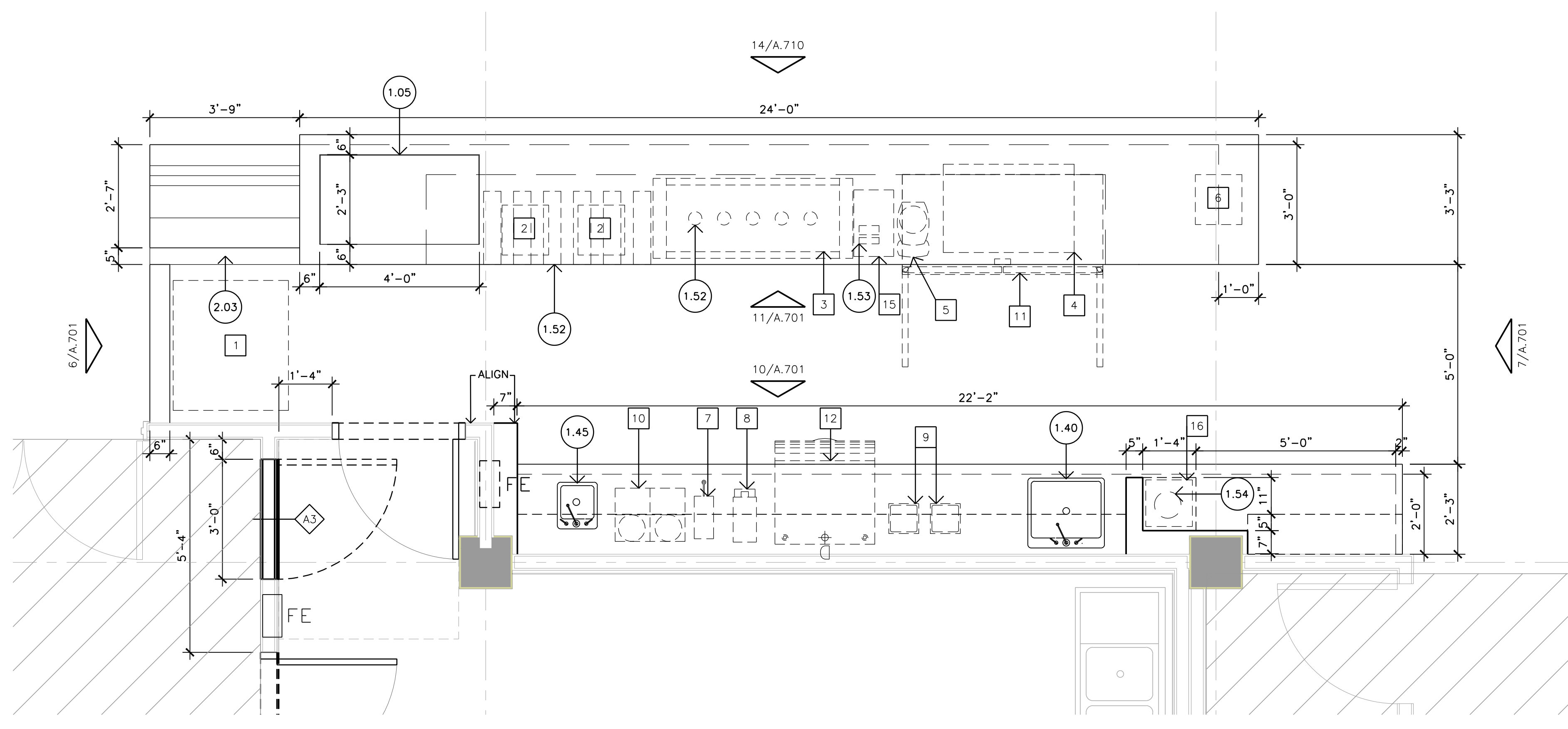

BAR ENLARGED FLOOR PLAN

1/2" = 1'-0" 5

- D1.01 Remove existing partition/wall. Remove existing finish construction back to existing base building structure. Clean and prepare to receive new construction. Contractor to maintain structural integrity of building.
- D1.03 Remove and relocate door, hardware and frame where indicated.
- D1.05 Existing exit sign to remain.
- D1.12 Remove light fixtures
- D1.13 Remove shelving
- D1.14 Remove and relocate fire extinguisher
- D1.15 Existing column to remain. All existing structure to remain.
- D1.16 Existing storefront to remain.
- D1.17 Existing door and hardware to remain
- D1.18 Existing window to remain.
- D1.25 Existing balcony and railing to remain.
- D1.26 Existing concrete slab to remain.
- D1.27 Existing restrooms to remain.
- D1.28 Existing janitor room to remain.
- D1.29 Existing elevator to remain.
- D1.30 Existing exterior walkway to remain.
- D1.31 Existing light fixture to remain.
- D1.32 Existing stairs to remain.
- 1.03 Scheduled door
- 1.04 Scheduled partition
- 1.05 Custom Millwork. Re: Millwork
- 1.17 Scheduled light fixture. Re: Electrical
- 1.23 Fire extinguisher
- 1.32 Custom glass display. Re: Millwork
- 1.33 Custom rope "screen". Rope by owner, installed by GC. Re: Millwork
- 1.34 Fixed panel with in-counter adjustable cup dispensers. Dispense-Rite ADJ-2
- 1.35 Furniture - OFOI
- 1.36 Custom Wall Shelf. Re: Millwork
- 1.40 S.S. sink. Re: MEP
- 1.45 S.S. Hand sink. Re: MEP
- 1.48 Existing Structure
- 1.49 Existing three compartment sink
- 1.50 Shelving system.
- 1.51 Steel bracket
- 1.52 Cup dispenser, Dispense Rite ADJ-2 (typ.) S.S.
- 1.53 Knock Chute, S.S. 6" x 5.5" x 4" Espresso Supply Inc.
- 1.54 6" S.S. grommet
- 2.01 2x6 Wood slot ceiling @ 10'-0" A.F.F.
- 2.02 Gyp. board ceiling @ 8'-6" A.F.F.
- 2.03 Salvaged rope installation
- 2.04 Slot wood ceiling hung with Unistrut @ 48" O.C. max.

KEY NOTES 3

Equipment list below is provided and installed by owner's food and beverage consultant. Re: MEP for details

- 1 Beverage Case
- 2 Coffee Registers
- 3 "Poursteady" Coffee Machine. See also water boiler requirements
- 4 "Strada" Espresso Machine. See also water pump and water filtration softener requirements
- 5 "Mazzer" Grinder
- 6 Bar Register
- 7 "Bunn" Hot Water Tower
- 8 "Bunn" Grinder
- 9 Blender
- 10 Brewing System
- 11 Undercounter Refrigerator
- 12 Undercounter Ice bin
- 13 Refrigerator
- 14 Ice Maker

Accessories below to be provided by owner's food and beverage consultant.

- 15 23 gallon wall hugger trash can (20x12x30 inches)
- 16 Open top, no cover trash can by Bobrick (B-2280)

LEGEND 2

- FP1. Refer to General sheets for typical graphic, symbols, abbreviation index, and "Master Keynote" list.
- FP2. All horizontal dimensions are provided on plans, and all vertical dimensions are provided on elevations and/or sections unless otherwise noted.
- FP3. Overall plan indicates exterior building dimensions, room numbers and names, door designations, window designations, exterior elevation designations, exterior plan designations, sign designations, and building section designations. All other plan information is indicated on referenced enlarged plans.
- FP4. Enlarged plans indicate interior building dimensions to face of partition material, interior plan detail designations, interior elevation designations, partition type designations, finish designations, and general building material.
- FP5. All dimensions are to be tied to a column line. Contractor will immediately report any omission of dimensions not tied to a column to the Architect prior to start of construction.
- FP6. Coordinate all MEP access panels not shown on architectural construction documents with Architect prior to installation.
- FP7. Provide adequate blocking as required at every location where millwork, wall light fixtures, TV brackets, plumbing fixtures, etc., are to be mounted.
- FP8. There are items shown, i.e. outlets, switches, thermostats, on the MEP drawings that are not drawn on the architectural plans. Contractor to coordinate and mount all MEP items per Architectural sheet A.730 unless noted otherwise.
- FP9. All equipment / areas labeled "ADA" are to be accessible. Refer to Texas Accessibility Guidelines and Standard Mounting Locations & Toilet Room Configuration.
- FP10. All wood blocking to be Fire Resistant

GENERAL NOTES 1

Consultants:

MEP:

Collaborative Engineering Group
 8904 Fairbanks N. Houston Suite 201
 Houston, TX 77064
 T: 281.598.1170
 F: 281.598.1130

SUNSET COFFEE

1019 Commerce St.
 Houston, TX 77002

Ownership of Instruments of Service:
 All reports, plans, specifications, computer files, field data, notes & other documents and instruments prepared by BRAVE / ARCHITECTURE as instruments of service shall remain the property of BRAVE / ARCHITECTURE. BRAVE / ARCHITECTURE shall retain all common law, statutory and other reserved rights, including the copyright thereto.

Issue:

2016.2.17 OWNER FINAL REVIEW
 2016.2.23 PERMIT

B/A Project No.: 15137
 Drawn By: MM
 Checked By: SM
 Date:
 Scale: AS NOTED

ENLARGED FLOOR PLANS

MATERIAL FINISH SCHEDULE

LOCATION	FINISH MARK	ITEM	MANUFACTURER	MANU. NUMBER	MANU. NAME	FINISH	COLOR	NOTE(S):
FLOOR	STN-1	CONCRETE STAIN	SURECRETE ECO-STAIN	701XX	SEMI-TRANSPARENT CONCRETE STAIN WATER BASED CONCENTRATED		TBD	
	SLR-1	CONCRETE SEALER	SURECRETE	DURA-KOTE PFC-120	2-HOUR CURE 67% SOLIDS CLEAR POLYASPARTIC COATING			
BASE	BS-1	WOOD BASE	-	-	1" X 4" PAINTED WOOD BASE	PAINTED, SEMI-GLOSS	TBD	SEMI-GLOSS PAINT
	BS-2	QUARRY BASE	DALTILE	-	4" X 8" QUARRY TILE		ASHEN GRAY	
WALLS	WPT-1	WALL PAINT	BENJAMIN MOORE	2146-10	DARK CELERY	SEMI-GLOSS	SEE NAME/NUMBER	
	WPT-2	WALL PAINT	BENJAMIN MOORE	2024-20	CITRON	SEMI-GLOSS	SEE NAME/NUMBER	
	WPT-3	WALL PAINT	BENJAMIN MOORE	2133-20	BLACK JACK	308 CHALKBOARD PAINT	SEE NAME/NUMBER	
	WTL-1	WALL CERAMIC	METRO	EQ-520/METR/WHI	METRO BLANCO WHITE	GLOSSY	WHITE	
	WWD-1	WOOD PLANKS	STIKWOOD	WEATHERED WOOD	COMMERCIAL PEEL & STICK		REC. WTHRD WOOD	
WPLAM-1	HEAVY DUTY WALLCOVERING	ACROVYN	ACROVYN 4000	.060" ACROVYN WALL COVERING (ENGINEERED PETG PANELS)	SUEDE	410 BRUSHED SILVER	PROVIDE ACROVYN ALUMINUM TRIM AND CAULK ON ALL EDGES	
WFRP-1	FIBERGLASS REINF. PLASTIC	MATCH EXISTING				WHITE-MATCH EXIST.	PATCH WALLS WHERE DOOR IS RELOCATED	
CEILINGS	CPT-1	CEILING PAINT	BENJAMIN MOORE	BLACK				PAIN CLG, WALL, AND ALL ACCESSORIES BLACK ABOVE 11'-0" AFF.
	CPT-2	CEILING PAINT	BENJAMIN MOORE	WHITE				
	CSLT-1	WOOD SLATS	CUSTOM	N/A		STAINED AND SEALED	TBD	1 1/2" X 6" - SOLID BIRCH
	CACT-1	ACOUSTICAL CEILING	ARMSTRONG	BLACK				
	CACT-2	WASHABLE LAY-IN	AMSTRONG	WHITE	CLEAN ROOM VL	SQUARE LAY-IN EDGE	WHITE	2' X 2' TILE
MILLWORK	PLAM-1	COMPACT GRADE LAMINATE	FORMICA	912	3/4" THK. COMPACT GRADE PANELS	MATTE	STOP RED	3/4" THK. COMPACT GRADE PANELS
	MTL-1	METAL LAMINATE	CHEMETAL		SATIN BRONZE ALUMINUM			
	WD-1	PINE SOLID WOOD	CUSTOM			STAINED AND SEALED	TBD	DIMENSIONALLY STABLE
	CS-1	THIN PORCELAIN SLAB	NEOLITH		12MM SLAB		IRON MOSS	CONTACT: LA NOVA TILE
	SS-1	SOLID SURFACE	CORIAN		1/2" THICK		WHITE	INSTALL LOOSE TO ALLOW FOR CLEANING
GL-1	GLASS			1/2" CLEAR LOW IRON TEMPERED				
MISC.	PT-1	WOOD TRIM PAINT	SHERWIN WILLIAMS			PAINTED, SEMI-GLOSS	TBD	PAINT FOR WINDOW TRIM
	SH-1	SHELVING SYSTEM	3-FORM	500.01	VERSA - FLOOR TO WALL	1" CHROMA SHELVES	TBD	(2) 12" X 48" SHELVES PER UNIT-VERIFY WIDTH TO ALIGN WITH EXIST WINDOW
	FLM-1	WINDOW FILM	3M		"FROSTED" FILM			

SEE NAME/NUMBER

B/A

BRAVE / ARCHITECTURE

4617 Montrose Blvd., Suite C.230
Houston, Texas 77006
Voice: 713.524.5858
Fax: 713.524.5868
studio@bravearchitecture.com
Contact: Silvana Micolich
smicolich@bravearchitecture.com



F. S. MOORE
4 MAY 2016

FINISH SCHEDULE

N.T.S. 8

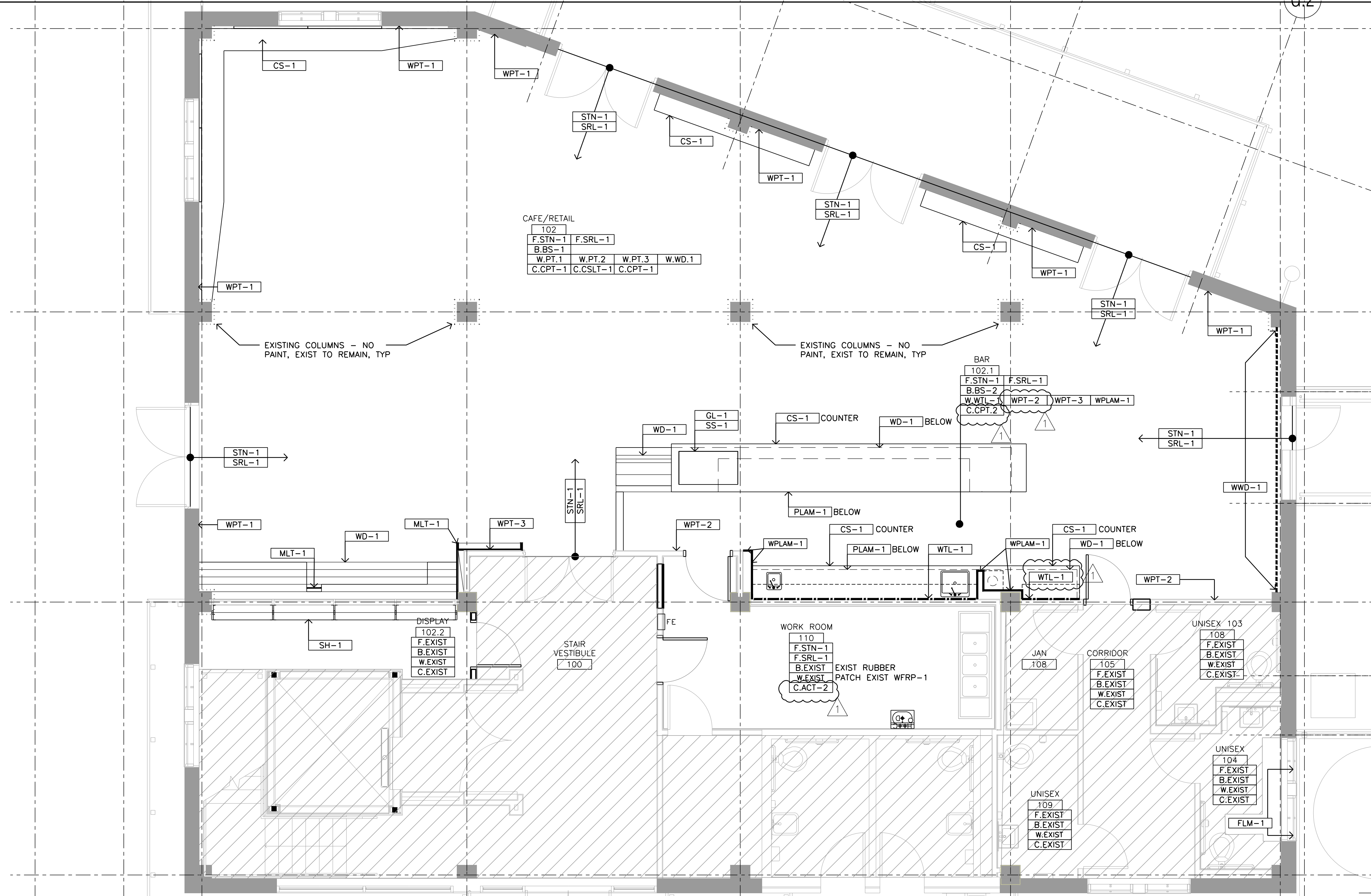

3

- FN1. Refer to General sheets for typical graphic, symbols, abbreviation index, and "Master Keynote" list.
- FN2. All horizontal dimensions are provided on plans, and all vertical dimensions are provided on elevations and/or sections unless otherwise noted.
- FN3. Overall plan indicates exterior building dimensions, room numbers and names, door designations, window designations, exterior elevations designations, exterior plan designations, sign designations, and building section designations. All other plan information is indicated on referenced enlarged plans.
- FN4. Enlarged plans indicate interior building dimensions to face of partition material, interior plan detail designations, interior elevation designations, partition type designations, finish designations, and general building material.
- FN5. All dimensions are to be tied to a column line. Contractor will immediately report any omission of dimensions not tied to a column line to the Architect prior to start of construction.
- FN6. Coordinate all MEP access panels not shown on architectural construction documents with Architect prior to installation.
- FN7. Provide adequate blocking as required at every location where millwork, wall light fixtures, TV brackets, plumbing fixtures, etc., are to be mounted.
- FN8. There are items shown, i.e. outlets, switches, thermostats, on the MEP drawings that are not drawn on the architectural plans. Contractor to coordinate and mount all MEP items per Architectural sheet A.730 unless noted otherwise.
- FN9. All equipment / areas labeled "ADA" are to be accessible, Refer to Texas Accessibility Guidelines sheet(s) and Standard Mounting Locations & Toilet Room Configuration.
- FN10. Provide moisture resistant finish as designated and as required in specifications.
- FN11. Provide non-slip surface finish in wet areas.
- FN12. Exposed interior structural steel to be exterior grade point finish.
- FN13. VCT and carpet tile finishes to be laid in basket weave pattern unless noted otherwise.
- FN14. Provide finishes as scheduled or selected by architect.

Consultants:

MEP:

Collaborative Engineering Group
8904 Fairbanks N. Houston Suite 201
Houston, TX 77064
T: 281.598.1170
F: 281.598.1130

SUNSET COFFEE

1019 Commerce St.
Houston, TX 77002

Ownership of Instruments of Service:
All reports, plans, specifications, computer files, field data, notes & other documents and instruments prepared by BRAVE / ARCHITECTURE as instruments of service shall remain the property of BRAVE / ARCHITECTURE. BRAVE / ARCHITECTURE shall retain all common law, statutory and other reserved rights, including the copyright thereto.

ISSUE:

2016.2.17 OWNER FINAL REVIEW
2016.2.23 PERMIT
2016.5.4 PERMIT COMMENTS

B/A Project No.: 15137
Drawn By: MM
Checked By: SM
Date:
Scale: AS NOTED

FINISH FLOOR PLAN & SCHEDULE

FLOOR PLAN

1/4" = 1'-0" 5

GENERAL NOTES

N.T.S. 1

A.151

FURNITURE SCHEDULE

ITEM NUMBER	ITEM	NAME	MODEL/SIZE	MANUFACTURER	QUANTITY	OBSERVATIONS
1	OUTDOOR TABLES	INOX TABLE, ROUND	SMALL	DESIGN WITHIN REACH	5	- BY OWNER
2	OUTDOOR CHAIRS	CATENA		LANDSCAPE FORMS	20	METALLIC SILVER - BY OWNER
3	BAR CHAIRS	REMY SIDE CHAIR		RESTORATION HARDWARE	34	GUNMETAL
4	BAR STOOLS	VINTAGE TOLEDO BAR STOOL		RESTORATION HARDWARE	16	WOOD SEAT AND GUNMETAL FINISH
5	LOUNGE SOFA	DECONSTRUCTION SHELTER ARM SOFA	7'-0"	RESTORATION HARDWARE	1	FABRIC = PRENNIALS TEXTURED LINEN WEAVE - COLOR: CAFE
6	COFFEE TABLE	MERCER ROUND COFFEE TABLE	30" DIAM., 16"H	RESTORATION HARDWARE	2	ZINC
7	LOUNGE CHAIRS	LIBRARY LEATHER CHAIR	34"W X 34"D X 29"H	RESTORATION HARDWARE	2	ITALIAN BROMPTON - LEATHER WALNUT OR COCOA COLOR
8	OTTOMANS	LIBRARY LEATHER OTTOMAN	26"W X 22"D X 15"H	RESTORATION HARDWARE	2	ITALIAN BROMPTON - LEATHER WALNUT OR COCOA COLOR
9	ROUND TABLES	FLATIRON ROUND DINING TABLE	48" DIAM., 30"H	RESTORATION HARDWARE	3	ESPRESSO ELM AND RUST METAL *1
10	BAR TABLE	FLATIRON BAR	64"W X 24"D X 36"H	RESTORATION HARDWARE	4	ESPRESSO ELM AND RUST METAL *1
11	GROUP TABLE	FLATIRON RECTANGULAR DINING TABLE	112"L X 39"W X 30"H; 198.2 LBS	RESTORATION HARDWARE	2	ESPRESSO ELM AND RUST METAL *1
12	DISPLAYS	WOOD AND STEEL SHELVING	50"W X 19 1/4"D X 78"H	RESTORATION HARDWARE	3	SALVAGED NATURAL FINISH *2
RESTORATION HARDWARE - PURCHASE CONTRACT GRADE, CONTACT RH CONTRACT - JILL PANZER 214.709.5227 JPANZER@RH.COM						
*1 = GC TO APPLY 5 COATS OF CLEAR MATTE POLYURETHANE.						
*2 = REMOVE STEEL RODS ACROSS BACK OF SHELVING UNIT.						

FURNITURE SCHEDULE

N.T.S. 8

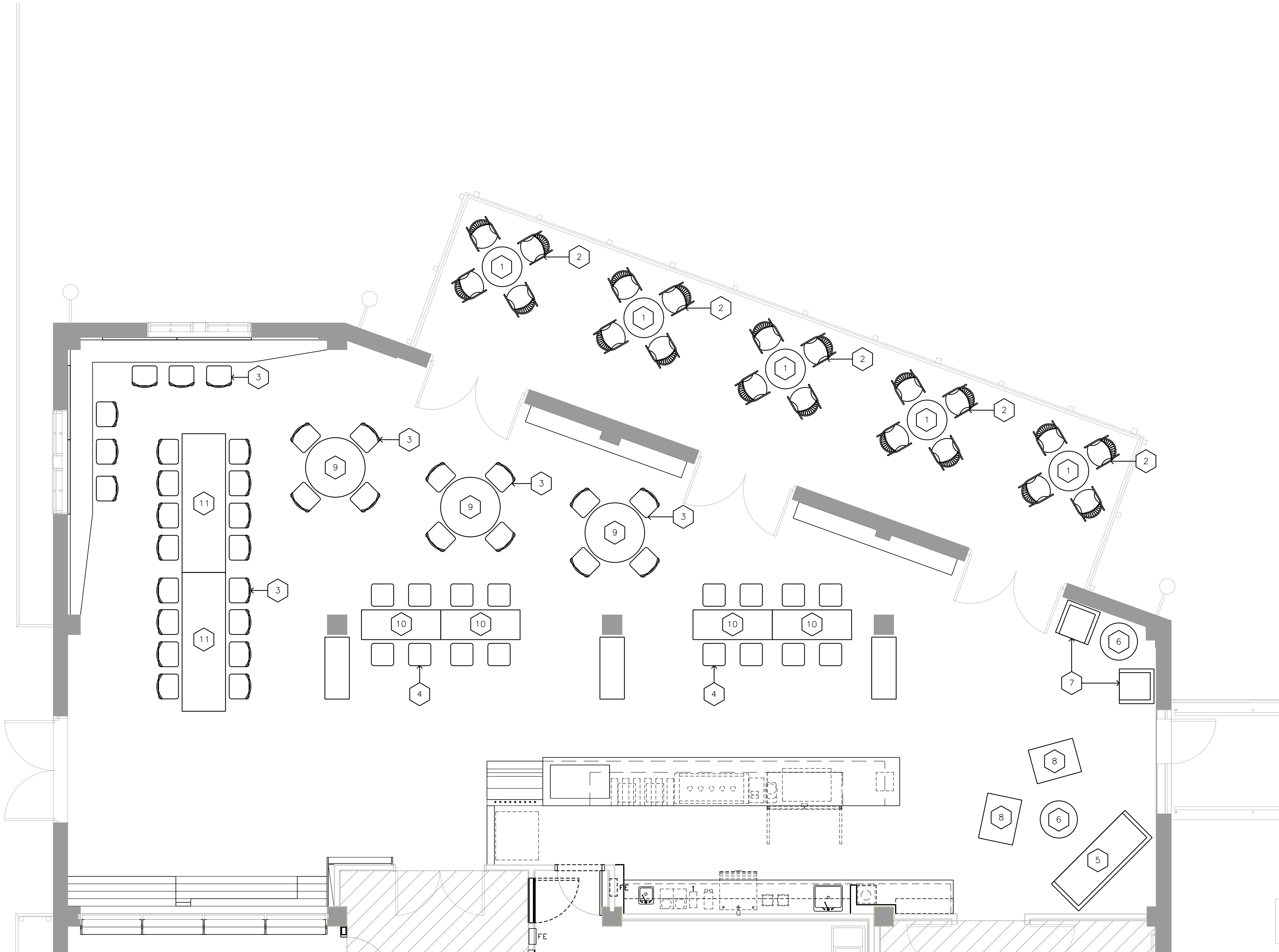

FLOOR PLAN

1/4" = 1'-0" 5

GENERAL NOTES

N.T.S. 1

B/A

BRAVE / ARCHITECTURE

4617 Montrose Blvd., Suite C.230
Houston, Texas 77006
Voice: 713.524.5858
Fax: 713.524.5868
studio@bravearchitecture.com
Contact: Silvana Micolich
smicolich@bravearchitecture.com

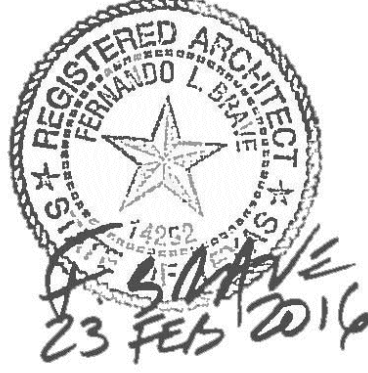

Consultants:

MEP:

Collaborative Engineering Group
8904 Fairbanks N. Houston Suite 201
Houston, TX 77064
T: 281.598.1170
F: 281.598.1130

SUNSET COFFEE

1019 Commerce St.
Houston, TX 77002

Ownership of Instruments of Service:
All reports, plans, specifications, computer files, field data, notes & other documents and instruments prepared by BRAVE / ARCHITECTURE as instruments of service shall remain the property of BRAVE / ARCHITECTURE. BRAVE / ARCHITECTURE shall retain all common law, statutory and other reserved rights, including the copyright thereto.

Issue:

2016.2.17 OWNER FINAL REVIEW
2016.2.23 PERMIT

B/A Project No.: 15137
Drawn By: MM
Checked By: SM
Date:
Scale: AS NOTED

FURNITURE LAYOUT

A.153

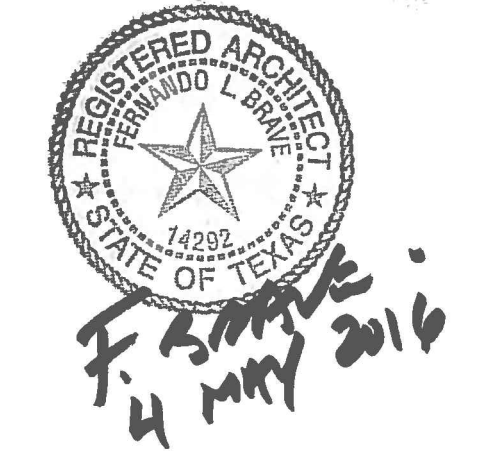

Consultants:

MEP:

Collaborative Engineering Group
8904 Fairbanks N. Houston Suite 201
Houston, TX 77064
T: 281.598.1170
F: 281.598.1130

- D1.01 Remove existing partition/wall. Remove existing finish construction back to existing base building structure. Clean and prepare to receive new construction.
- D1.03 Contractor to maintain structural integrity of building.
- D1.05 Remove and relocate door, hardware and frame where indicated
- D1.12 Existing exit sign to remain.
- D1.13 Remove light fixtures
- D1.14 Remove shelving
- D1.15 Remove and relocate fire extinguisher
- D1.16 Existing column to remain. All existing structure to remain.
- D1.17 Existing storefront to remain.
- D1.18 Existing door and hardware to remain
- D1.25 Existing window to remain.
- D1.26 Existing balcony and railing to remain.
- D1.27 Existing concrete slab to remain.
- D1.28 Existing restrooms to remain.
- D1.29 Existing janitor room to remain.
- D1.30 Existing elevator to remain.
- D1.31 Existing exterior walkway to remain.
- D1.32 Existing light fixture to remain.
- D1.33 Existing stairs to remain.
- 1.03 Scheduled door
- 1.04 Scheduled partition
- 1.05 Custom Millwork. Re: Millwork
- 1.17 Scheduled light fixture: Re: Electrical
- 1.23 Fire extinguisher
- 1.32 Custom glass display. Re: Millwork
- 1.33 Custom rope "screen". Rope by owner, installed by GC. Re: Millwork
- 1.34 Fixed panel with in-counter adjustable cup dispensers.
- 1.04 Dispense-Rite ADJ-2
- 1.35 Furniture - OFOI
- 1.36 Custom Wall Shelf. Re: Millwork
- 1.40 S.S. sink. Re: MEP
- 1.45 S.S. Hand sink. Re: MEP
- 1.48 Existing Structure
- 1.49 Existing three compartment sink
- 1.50 Shelving system.
- 1.51 Steel bracket
- 1.52 Cup dispenser, Dispense Rite ADJ-2 (typ.) S.S.
- 1.53 Knock Chute, S.S. 6" x 5.5" x 4" Espresso Supply Inc.
- 1.54 6" S.S. grommet
- 2.01 2x6 Wood slot ceiling @ 10'-0" A.F.F.
- 2.02 Gyp. board ceiling @ 8'-6" A.F.F.
- 2.03 Salvaged rope installation
- 2.04 Slat wood ceiling hung with Unistrut @ 48" O.C. max.
- 2.05 Stained wood shelves with black steel brackets
- 2.06 Stained wood shelves with internal steel support

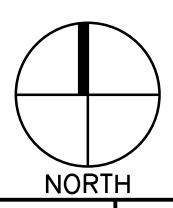
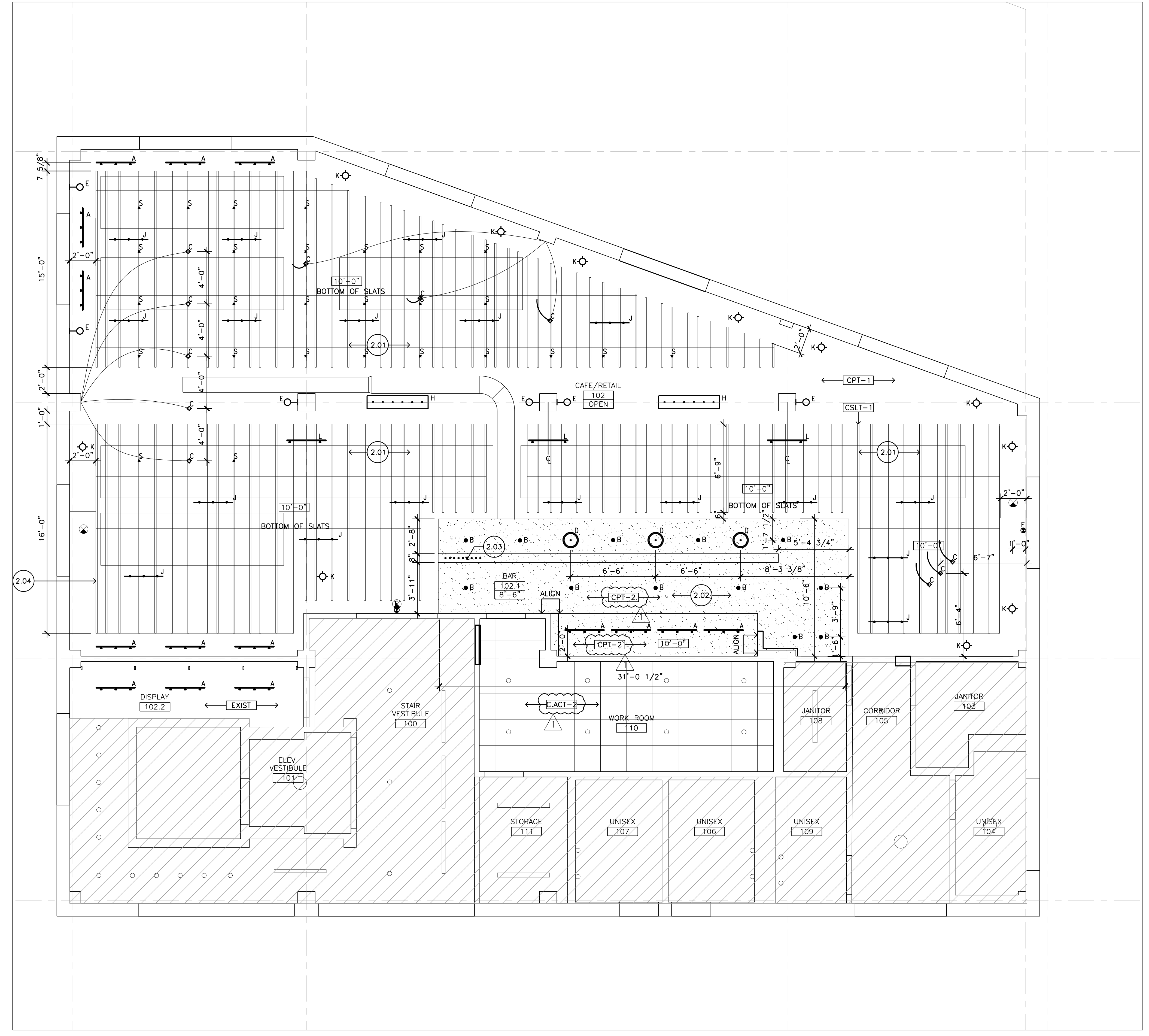

1/4" = 1'-0" 5

KEY NOTES 3

- GYPSUM BOARD CEILING/FURROW. SEE ELEVATIONS AND SECTIONS.
- TRACK LIGHT (3 HEADS)
- RECESSED "CAN" LIGHT FIXTURE. SEE MEP
- PENDANT LIGHT FIXTURE
- PENDANT LIGHT FIXTURE
- WALL SCONCE LIGHT FIXTURE. SEE MEP
- EXISTING EXIT SIGN
- CUSTOM PENDANT BY OWNER
- LINEAR PENDANT FIXTURE
- TRACK LIGHT
- PENDANT ADJUSTABLE MONOPOINT
- TRACK LIGHT (2 HEADS)
- PENDANT FIXTURE SWAG HOOK. INSTALL AT 4'-0" O.C. GRID TO HANG "C" FITURES.

RCP LEGEND 2

- RCP1. Refer to General sheets for typical graphic, symbols, abbreviation index, and "Master Keynote" list.
- RCP2. Refer to interior elevations for furred down heights U.N.O.
- RCP3. Center lay-in acoustical ceiling system in each room with equal tile dimensions on opposite walls unless otherwise noted. Notify architect if any tile abutting the partition is less than 6" in width. Secondary wall angles to support "short" runs will not be accepted.
- RCP4. In lay-in acoustical ceilings locate all MEP items not including supply/return air grilles, emergency lighting, sprinkler heads, etc. in center of tile unless otherwise noted.
- RCP5. In gypsum board ceilings locate all MEP emergency lighting, sprinkler heads in center of space and equal distant apart from each other unless otherwise noted.
- RCP6. Coordinate all MEP ceiling and access panels not shown on the architectural construction documents with architect prior to installation.
- RCP7. In exposed ceilings evenly space all fixtures at or below exposed structure or MEP ductwork. Coordinate with MEP to provide lighting "around" final MEP layout to avoid "dark" spots.

SUNSET COFFEE

1019 Commerce St.
Houston, TX 77002

Ownership of Instruments of Service:
All reports, plans, specifications, computer files, field data, notes & other documents and instruments prepared by BRAVE / ARCHITECTURE as instruments of service shall remain the property of BRAVE / ARCHITECTURE. BRAVE / ARCHITECTURE shall retain all common law, statutory and other reserved rights, including the copyright thereto.

Issue:

2016.2.17 OWNER FINAL REVIEW
2016.2.23 PERMIT
2016.5.4 PERMIT COMMENTS

B/A Project No.: 15137
Drawn By: MM
Checked By: SM
Date:
Scale: AS NOTED

REFLECTED CEILING FLOOR PLAN



LOOSE ANGLE LINTEL SCHEDULE

CLEAR SPAN	STEEL ANGLES FOR 4" MASONARY WALL OPENINGS	NOTES:
4'-0" OR LESS	4" x 4" x 1/4"	1 THRU 8
4'-1" TO 5'-0"	4" x 4" x 1/4"	1 THRU 8
5'-1" TO 6'-0"	6" x 4" x 5/16"	1 THRU 8
6'-1" TO 7'-0"	6" x 4" x 5/16"	1 THRU 8
7'-1" TO 8'-0"	6" x 4" x 5/16"	1 THRU 8
8'-1" OR GREATER		9

- NOTES:
- PROVIDE 8" MIN. BEARING FOR ALL ANGLES.
 - PROVIDE CONTINUOUS LINTELS BETWEEN ADJACENT OPENINGS SEPARATED BY 2'-0" OR LESS
 - THIS SCHEDULE APPLIES ONLY TO NON LOAD BEARING WALLS.
 - ANY AND ALL LINTELS IN LOAD BEARING WALLS SHALL BE SCHEDULED AND DETAILED BY STRUCTURAL
 - IN CASES OF MASONRY VENEER WALLS WITH CMU BACK-UP THE VENEER LINTEL SHALL BE SELECTED PER THIS SCHEDULE. REFER TO STRUCTURAL FOR CMU LINTEL SCHEDULING AND DETAILING.
 - PROVIDE HORIZONTAL EXPANSION JOINTS AT EA. END OF LINTEL
 - PROVIDE END DAMS PER DIVISION SEVEN AND DETAILS
 - MEMBER SIZES INDICATED PER THIS SCHEDULE SHALL ONLY SUPPLEMENT INFORMATION FOUND ELSEWHERE IN THE CONSTRUCTION DOCUMENTS, AND SHALL NOT SUPERSEDE MEMBER SIZES NOTED ON SECTIONS, DETAILS, OR STRUCTURAL DRAWINGS.
 - REFER TO SECTIONS, DETAILS, AND STRUCTURAL DRAWINGS.

OPENING JAMB STUD FRAMING SCHEDULE

CLEAR OPENING WIDTH	MIN. NO. OF STUDS @ EA. JAMB	NOTES:
5'-4" OR LESS	2	1 THRU 4
5'-5" TO 8'-0"	3	1 THRU 4
8'-1" TO 10'-8"	4	1 THRU 4
10'-9" TO 13'-4"	5	1 THRU 4
13'-5" TO 16'-0"	6	1 THRU 4
16'-1" OR GREATER		5

- NOTES:
- BASED ON 16" @ 24" O.C. STUD SPACING
 - THIS SCHEDULE APPLIES ONLY TO CFMF
 - JAMB STUDS ARE TO BE CONNECTED TO EACH OTHER
 - REFER TO PARTITION TYPES FOR SIZING AND SPACING OF WALL STUDS
 - REFER TO STRUCTURAL REINFORCEMENT

GAUGE / THICKNESS SCHEDULE

US STANDARD GAUGE	MINIMUM BASE METAL THICKNESS	
	IN.	MIL.
26	.0179	18
25	.0209	21
24	.0239	24
22	.0299	30
20	.0359	36
18	.0478	48
16	.0598	60
14	.0747	75
12	.1046	105
10	.1345	135

2

- PT1. Refer to index sheet G.001 and G.002 for typical graphical symbols and abbreviation index.
- PT2. Refer to sheet G.020 and G.021 for accessibility guidelines.
- PT3. All partitions in wet or moist locations will receive moisture resistant sheathing. Refer to plans and specifications for locations of wet or moist areas and material required.
- PT4. Refer to the enlarged floor plans for the locations of the partitions unless noted otherwise.
- PT5. Refer to this sheet for standard details pertaining to the partitions types. One or more of the details will pertain to each partition. It is the responsibility of the contractor to coordinate and reference all standard details to each partition. The contractor is to immediately contact the Architect if any questions arise.
- PT6. Refer to door schedules, window types, and details for construction of openings in the partitions.
- PT7. For all smoke and/or fire rated partitions the designated UL design is to be maintained without exception. All penetrations and openings are to be sealed with an approved UL design or designated detail. These drawings do not list all the UL designs necessary to maintain a partition's smoke and/or fire rating. It is the responsibility of the General Contractor to ensure all rated partitions fully meet UL requirements.
- PT8. Adequate blocking is required at every location where millwork, wall light fixtures, TV brackets, plumbing fixtures, etc. are to be mounted. Blocking is in addition to noted partition construction, and is not meant to replace the partition construction. Blocking is not to interfere or degrade a partition's smoke and/or fire rating.
- PT9. Provide corner guard at every corner of exposed gypsum wall board assembly, Re: Finish Plan.
- PT10. Refer to 2/A.630 for drywall partition design limitations.

SUNSET COFFEE

1019 Commerce St.
Houston, TX 77002

Ownership of Instruments of Service:
All reports, plans, specifications, computer files, field data, notes & other documents and instruments prepared by BRAVE / ARCHITECTURE as instruments of service shall remain the property of BRAVE / ARCHITECTURE. BRAVE / ARCHITECTURE shall retain all common law, statutory and other reserved rights, including the copyright thereto.

ISSUE:
2016.2.17 OWNER FINAL REVIEW
2016.2.23 PERMIT

B/A Project No.: 15137
Drawn By: MM
Checked By: SM
Date:
Scale: AS NOTED

PARTITION TYPES

A.630

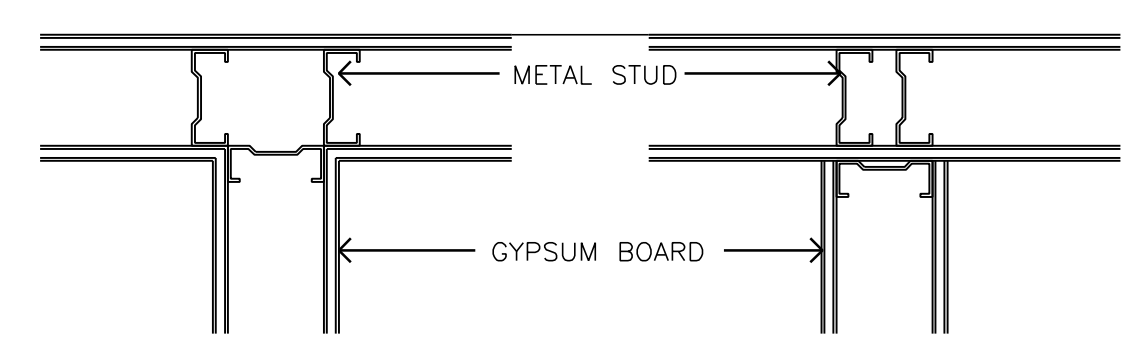

PARTITION TEE
PARTITION TEE @ CORRIDOR OR RATED WALL

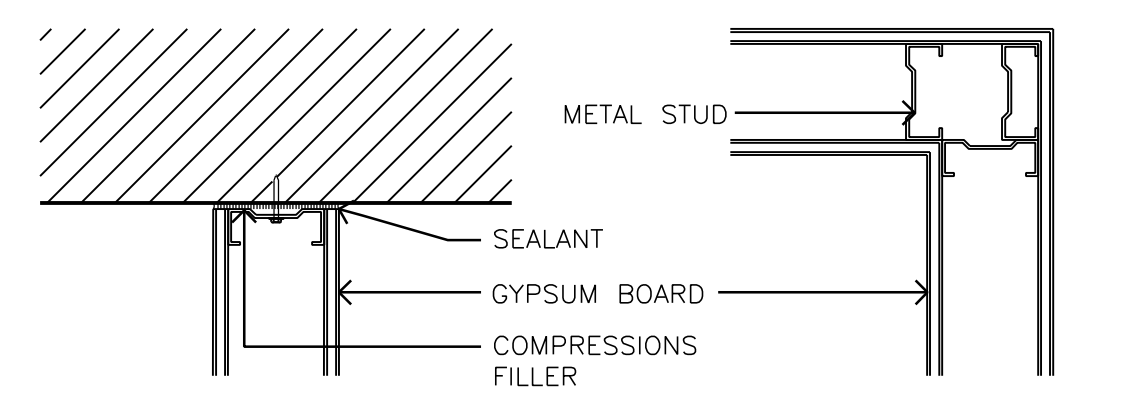

PARTITION TEE @ ADJOINING WALL
TYPICAL CORNER CONDITION

NOTE:
REFER TO PLANS FOR PARTITION TYPE.
REFER TO PARTITION TYPES FOR SIZE AND CONSTRUCTION

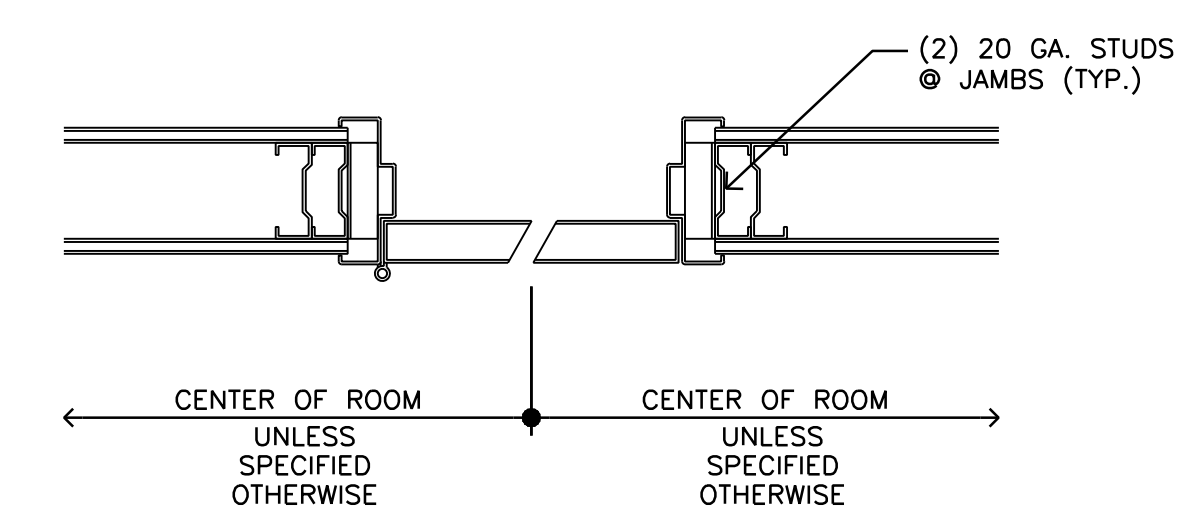

TYPICAL OPENING @ MIDDLE OF ROOM UNLESS NOTED OTHERWISE

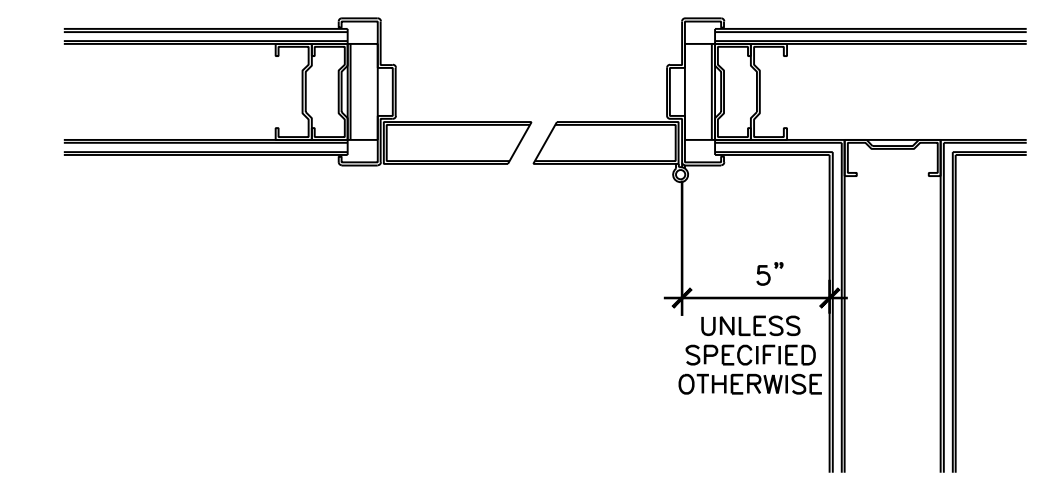

TYPICAL OPENING @ CORNER OF ROOM UNLESS NOTED OTHERWISE

NOTE:
REFER TO DOOR SCHEDULE FOR DOOR SIZE
REFER TO PLANS FOR PARTITION TYPE.
REFER TO PARTITION TYPES FOR SIZE AND CONSTRUCTION

PARTITION TYPE "-"

N.T.S. 11

TYPICAL PARTITION CONNECTIONS

N.T.S. 8

TYPICAL PARTITION OPENINGS

N.T.S. 5

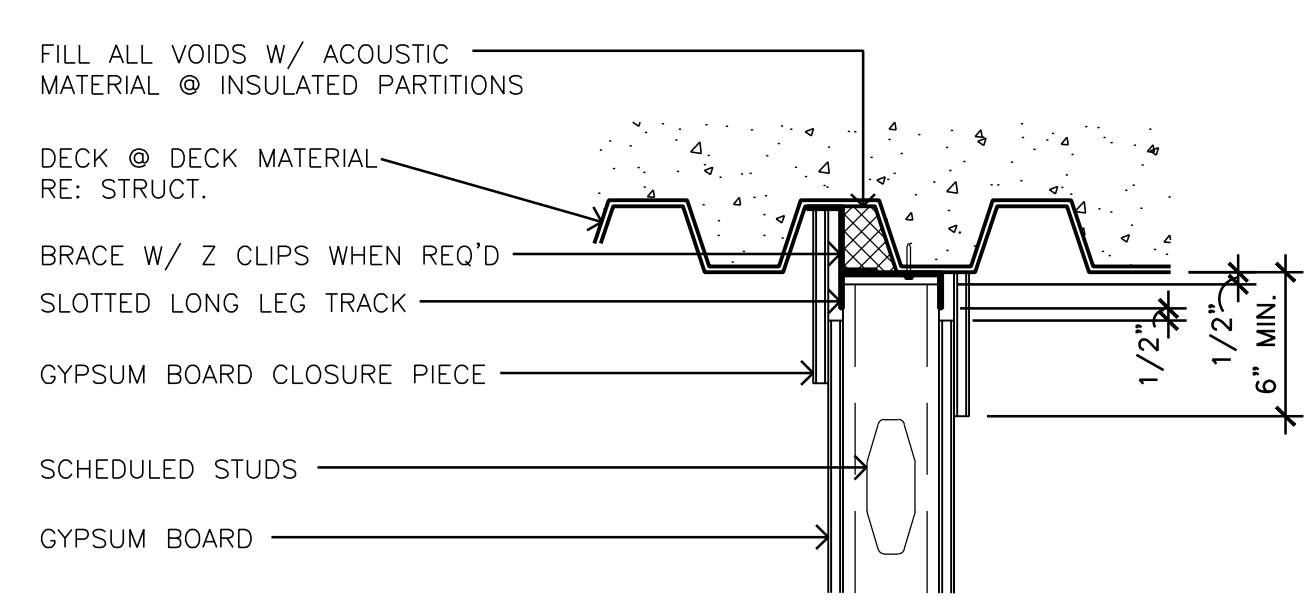

PARTITION @ DECK RUNNING PARALLEL TO RIBS

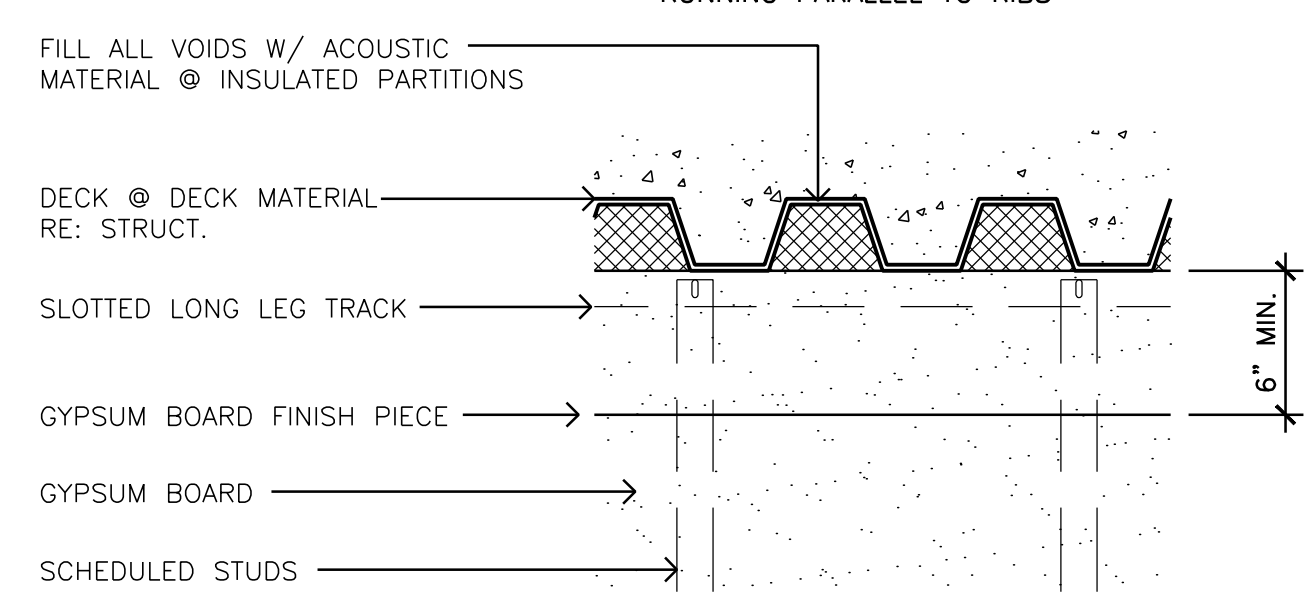

PARTITION @ DECK RUNNING PERPENDICULAR TO RIBS

NOTE:
REFER TO PLANS FOR PARTITION TYPE.
REFER TO PARTITION TYPES FOR SIZE AND CONSTRUCTION

A. BASE LIMITING HEIGHTS FOR PARTITIONS ON A DEFLECTION CRITERIA RATIO (L/360) OF LOAD WHERE FLOOR TO STRUCTURE HEIGHTS OF PARTITION EXCEEDS THE LIMITING HEIGHT. PROVIDE SUPPLEMENTAL BRACING TO THE STRUCTURE OVERHEAD AS REQUIRED TO MAINTAIN DEFLECTION RATIO (L/360) WITHIN LOAD.

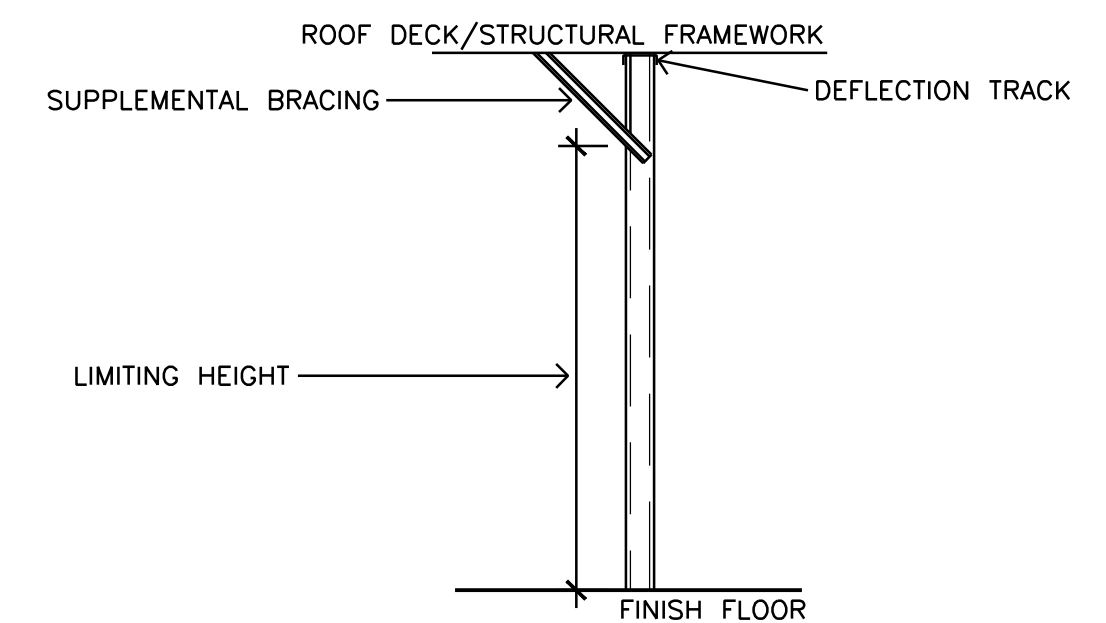

- B. FOR PARTITIONS WITH "BRITTLE" FINISHES SUCH AS PLASTER AND CERAMIC TILE. DESIGN PARTITION SYSTEM TO MAINTAIN DEFLECTION RATIO WITHIN LOAD.
- C. SUSPENDED CEILINGS SHALL NOT BE CONSIDERED AS BRACING.
- D. WHERE GYPSUM WALLBOARD IS THE SUBSTRATE FOR APPLICATION OF CERAMIC TILE. PROVIDE "WATER-RESISTANT, TYPE X" BOARD.
- E. STC RATING SHOWN FOR SOUND WALLS ARE BASED ON LABORATORY TESTED ASSEMBLIES AND DO NOT NECESSARILY INDICATE THE ACTUAL STC RATING OF THE COMPLETED WORK.
- F. PARTITIONS ARE NOT STRUCTURAL ELEMENTS, AND ARE NOT DESIGNED TO CARRY VERTICAL LOADS

PARTITION TYPE "-"

N.T.S. 10

TYPICAL PARTITION @ DECK DETAILS

N.T.S. 7

DRYWALL PARTITION DESIGN CRITERIA

N.T.S. 4

GENERAL NOTES

1

4617 Montrose Blvd., Suite C.230
Houston, Texas 77006
Voice: 713.524.5858
Fax: 713.524.5868
studio@bravearchitecture.com
Contact: Silvana Micolich
smicolich@bravearchitecture.com



Consultants:

MEP: Collaborative Engineering Group
8904 Fairbanks N. Houston Suite 101
Houston, TX 77064
T: 281.598.1170
F: 281.598.1130

SUNSET COFFEE

1019 Commerce St.
Houston, TX 77002

Ownership of Instruments of Service:
All reports, plans, specifications, computer files, field data,
notes & other documents and instruments prepared by
BRAVE / ARCHITECTURE as Instruments of Service shall
remain the property of BRAVE / ARCHITECTURE.
BRAVE / ARCHITECTURE shall retain all common law,
statutory and other reserved rights, including the copyright
thereto.

Issue:

2016.2.17 OWNER FINAL REVIEW
2016.2.23 PERMIT
2016.5.4 PERMIT COMMENTS

B/A Project No.: 15137
Drawn By: MM
Checked By: SM
Date:
Scale: AS NOTED

PARTITION TYPES

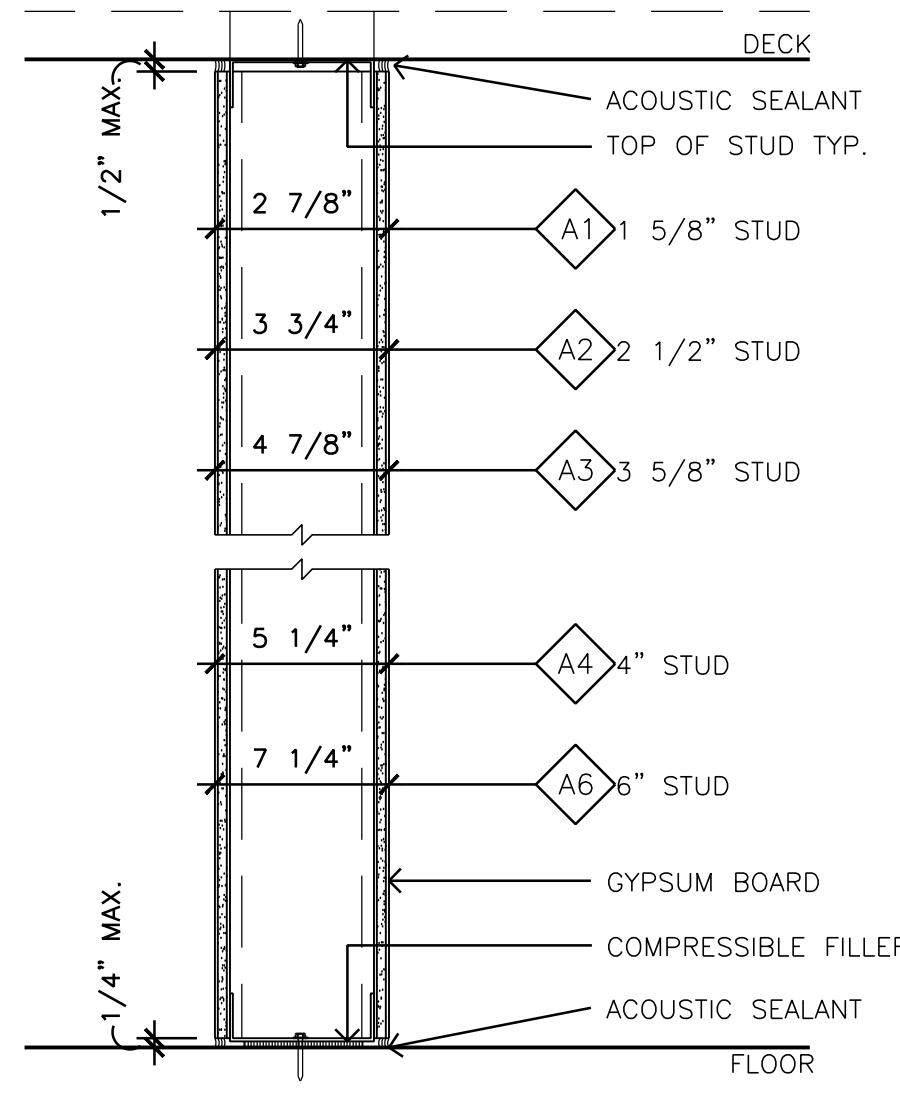

PARTITION TYPE "A"

25ga. METAL STUDS @ 16" O.C. WITH ONE (1) LAYER OF 5/8" THICK GYPSUM BOARD EACH SIDE.

*AT WET WALL LOCATIONS PROVIDE "DENSSHIELD TILE GUARD"

Table with 2 columns: PARTITION TYPE, UNBRACED LIMITING HT. Rows A1 through A6.

N.T.S. 2

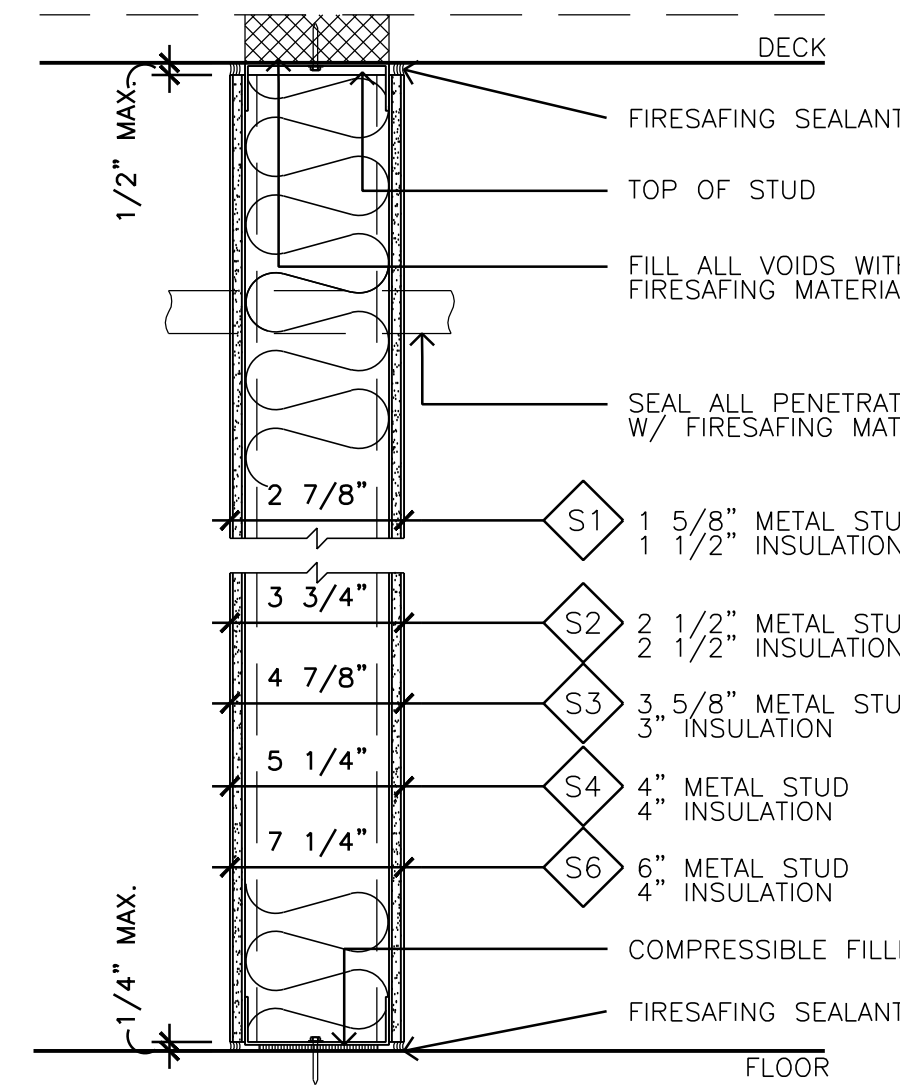

PARTITION TYPE "S" (ONE (1) HOUR FIRE RATING)

25ga. METAL STUDS @ 16" O.C. WITH ONE (1) LAYER OF 5/8" THICK GYPSUM BOARD EACH SIDE.

*AT WET WALL LOCATIONS PROVIDE "DENSSHIELD TILE GUARD"

Table with 4 columns: PARTITION TYPE, UNBRACED LIMITING HT., FIRE RATING @ DESIGNATED PARTITIONS, REFERENCE TO PLANS, MINIMUM SCR REQUIRED. Rows S1 through S6.

PARTITION TYPES

51. Framing Members - Floor and Ceiling Runners - Not Shown - As an alternate to Item 1 - For use with Item 20, proprietary channel shaped runners, min depth to accommodate stud size, galv steel, attached to floor and ceiling with fasteners spaced 24 in. OC max.

PARTITION TYPE "N"

25ga. METAL STUDS @ 16" O.C. WITH ONE (1) LAYER OF 5/8" THICK GYPSUM BOARD.

*AT WET WALL LOCATIONS PROVIDE "DENSSHIELD TILE GUARD"

Table with 2 columns: PARTITION TYPE, UNBRACED LIMITING HT. Rows L1 through L6.

N.T.S. 4

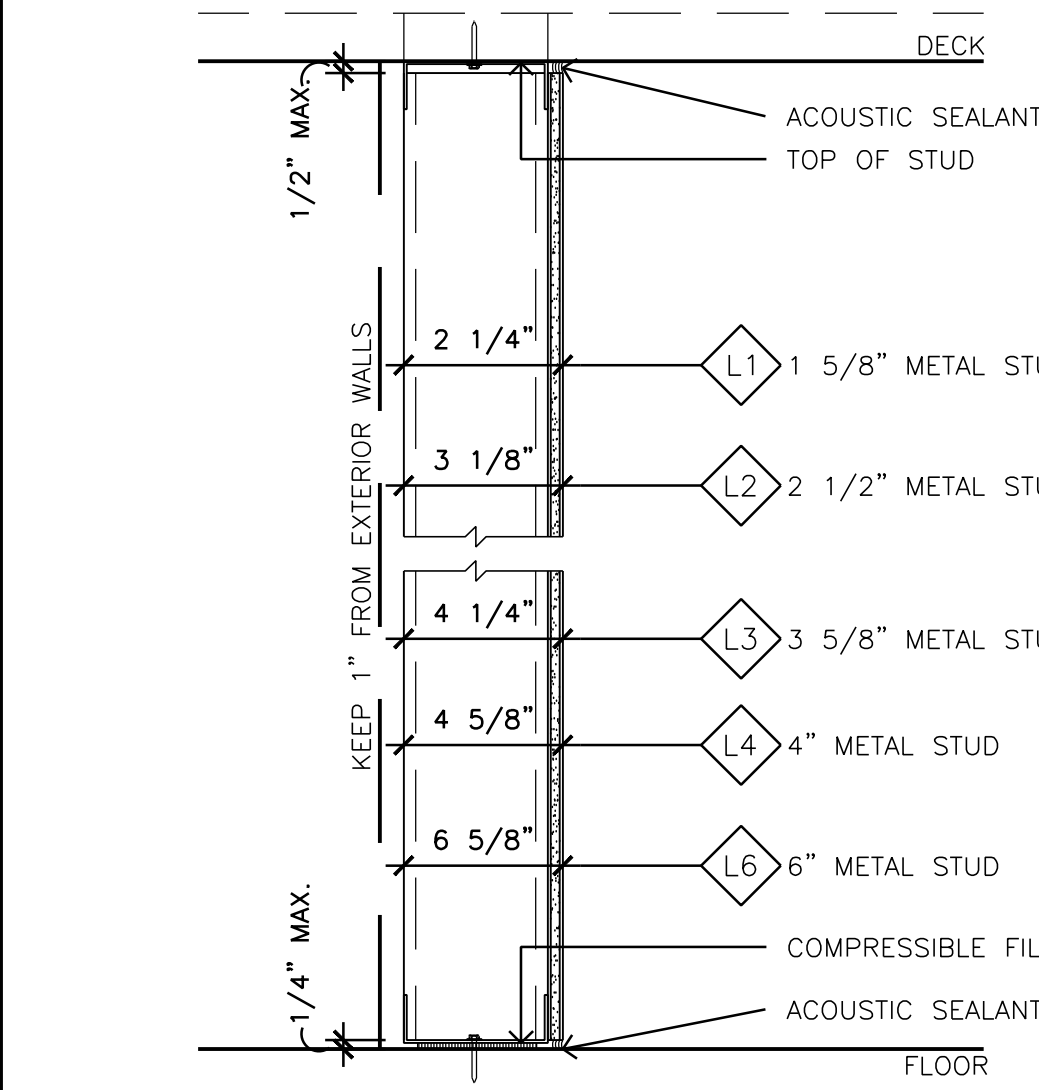

PARTITION TYPE "L"

25ga. METAL STUDS @ 16" O.C. WITH ONE (1) LAYER OF 5/8" THICK GYPSUM BOARD.

*AT WET WALL LOCATIONS PROVIDE "DENSSHIELD TILE GUARD"

Table with 2 columns: PARTITION TYPE, UNBRACED LIMITING HT. Rows L1 through L6.

PARTITION TYPES

PARTITION TYPE "N"

25ga. METAL STUDS @ 16" O.C. WITH ONE (1) LAYER OF 5/8" THICK GYPSUM BOARD.

*AT WET WALL LOCATIONS PROVIDE "DENSSHIELD TILE GUARD"

Table with 2 columns: PARTITION TYPE, UNBRACED LIMITING HT. Rows L1 through L6.

PARTITION TYPE "S"

25ga. METAL STUDS @ 16" O.C. WITH ONE (1) LAYER OF 5/8" THICK GYPSUM BOARD EACH SIDE.

*AT WET WALL LOCATIONS PROVIDE "DENSSHIELD TILE GUARD"

Table with 2 columns: PARTITION TYPE, UNBRACED LIMITING HT. Rows S1 through S6.

N.T.S. 1

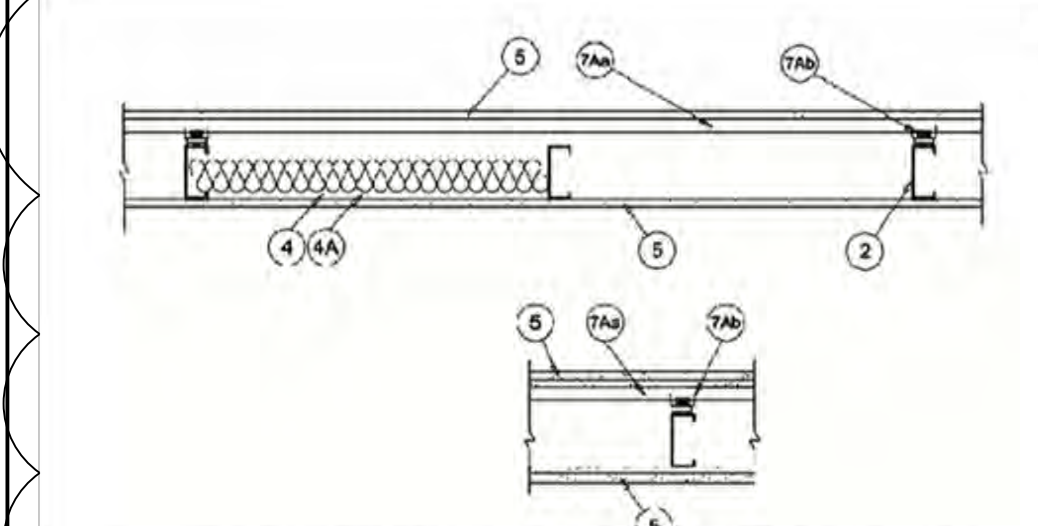

1. Floor and Ceiling Runners - (Not Shown) - For use with Item 2 - Channel shaped, fabricated from min 20 HSG corrosion-protected steel, max depth to accommodate stud size, min 1-1/4 in., long legs, attached to floor and ceiling with fasteners spaced 24 in. OC max.

CRACO HFG INC. - SmartTrack25™

HARINO/WARE, DIV OF WARE INDUSTRIES INC. - Viper20™

18. Framing Members - Floor and Ceiling Runner - Not Shown - In lieu of Item 1 - For use with Item 2C, proprietary channel shaped runners, 1-1/4 in. wide by 3-5/8 in. deep fabricated from min 0.035 in. thick galv steel, attached to floor and ceiling with fasteners spaced 24 in. OC max.

CALIFORNIA EXPANDED METAL PRODUCTS CO. - Viper25™

HARINO/WARE, DIV OF WARE INDUSTRIES INC. - Viper20™

13. Framing Members - Floor and Ceiling Runners - (Not Shown) - In lieu of Item 1 - Channel shaped, attached to floor and ceiling with fasteners 24 in. OC max.

ALLSTEEL & GYPSUM PRODUCTS INC. - Type SUPREME Framing System

CONSOLIDATED FABRICATORS CORP. BUILDING PRODUCTS DIV. - Type SUPREME Framing System

QUAIL RUN BUILDING MATERIALS INC. - Type SUPREME Framing System

SCAFCO STEEL STUD MANUFACTURING CO. - Type SUPREME Framing System

20. Framing Members - Steel Studs - As an alternate to Item 2 - Proprietary channel shaped steel studs, min depth to accommodate stud size, galv steel, attached to floor and ceiling with fasteners spaced 24 in. OC max.

RONDO BUILDING SERVICES PVT LTD. - Rondo Lipped Wall Stud

3. Wood Structural Panel Sheathing - (Optional, For use with Item 5 Only) - (Not Shown) - 4" W.P. wide, 7/16 in. thick oriented strand board (OSB) or 3/32 in. thick structural sheathing (sheetrock) complying with DCC P51 or P52, or AIA Standard P59-100, manufactured with exterior grade, applied horizontally or vertically to the steel studs. Vertical joints centered on studs and staggered one stud cavity on opposite sides of studs. Wallboard secured to studs with 1-1/4 in. long Type S-12 steel screws spaced 16 in. OC, corner and 12 in. OC at perimeter and 12 in. OC in the field. Min. voids gypsum panels attached over OSB or plywood panels and fastener lengths for gypsum panels increased by min. 1/2 in.

4. Batts and Blankets - (Required as indicated under Item 5) - Mineral wool batts, friction fitted between studs and runners. Min non thickness as indicated under Item 5. See Batts and Blankets (BENV or BZZZ) Categories for names of Classified companies.

16. Batts and Blankets - (Optional) - Placed in stud cavities, any min. 3-1/2 in. thick glass fiber insulation bearing the UL Classification Marking as Surface Burning Characteristics and/or Fire Resistance. See Batts and Blankets (BENV or BZZZ) Categories for names of Classified companies.

18. Batts and Blankets - For use with Item 5K. Placed in stud cavities, any min. 3-1/2 in. thick glass fiber insulation bearing the UL Classification Marking as Surface Burning Characteristics and/or Fire Resistance. See Batts and Blankets (BENV or BZZZ) Categories for names of Classified companies.

5. Gypsum Board - Gypsum panels with beveled, square or tapered edges, applied vertically or horizontally. Vertical joints centered over studs and staggered one stud cavity on opposite sides of studs. Wallboard secured to studs with 1-1/4 in. long Type S-12 steel screws spaced 16 in. OC, corner and 12 in. OC in the field. Min. voids gypsum panels attached over OSB or plywood panels and fastener lengths for gypsum panels increased by min. 1/2 in.

Table: Gypsum Board Protection on Each Side of Wall. Columns: Rating, Hr, Min Stud Depth, In, Items 2C, 2D, 2F, 2G, 2H, 2I, 2J, 2K, 2L, 2M, 2N, 2O, 2P, 2Q, 2R, 2S, 2T, 2U, 2V, 2W, 2X, 2Y, 2Z. Rows 1 through 6.

CGC INC. - 1/2 in. thick Type C, IP-X2 or IPC-AR; 5/8 in. thick Type AR, C, IP-AR, IP-X1, IP-X2, IPC-AR, SCA, SHK, or 3/4 in. thick Type IP-X3 or ULTRACODE

UNITED STATES GYPSUM CO. - Type USGX, SXX

USG BORAL ZAWAY DRYWALL L L C SFZ - Type SCX

USG MEXICO S A DE C V - Type SCX

CGC INC. - 1/2 in. thick Type C, IP-X2 or IPC-AR; 5/8 in. thick Type AR, C, IP-AR, IP-X1, IP-X2, IPC-AR, SCA, SHK, or 3/4 in. thick Type IP-X3 or ULTRACODE

UNITED STATES GYPSUM CO. - Type USGX

USG BORAL ZAWAY DRYWALL L L C SFZ - 1/2 in. Type C, 5/8 in. Types C, SCX

51. Gypsum Board - (Not Shown) - (As an alternate to Item 5) - Nom. 5/8 in. thick gypsum panels with beveled, square or tapered edges, applied vertically or horizontally. Vertical joints centered over studs and staggered one stud cavity on opposite sides of studs. Wallboard secured to studs with 1-1/4 in. long Type S-12 steel screws spaced 16 in. OC, corner and 12 in. OC in the field. Min. voids gypsum panels attached over OSB or plywood panels and fastener lengths for gypsum panels increased by min. 1/2 in.

CGC INC. - 1/2 in. thick Type C, IP-X2 or IPC-AR; 5/8 in. thick Type AR, C, IP-AR, IP-X1, IP-X2, IPC-AR, SCA, SHK, or 3/4 in. thick Type IP-X3 or ULTRACODE

UNITED STATES GYPSUM CO. - Type USGX

USG BORAL ZAWAY DRYWALL L L C SFZ - 1/2 in. Type C, 5/8 in. Types C, SCX

51. Gypsum Board - (Not Shown) - (As an alternate to Item 5) when used as the base layer on one or both sides of wall between 1/2 in. or 5/8 in. thick products as specified. For direct attachment only to steel studs Item 2A, not to be used with Item 3. Nom 5/8 in. or 3/4 in. thick lead backed gypsum panels with beveled, square or tapered edges, applied vertically. Vertical joints centered over studs and staggered one stud cavity on opposite sides of studs. Wallboard secured to studs with 1-1/4 in. long Type S-12 steel screws spaced 16 in. OC, corner and 12 in. OC in the field. Min. voids gypsum panels attached over OSB or plywood panels and fastener lengths for gypsum panels increased by min. 1/2 in.

CGC INC. - 1/2 in. thick Type C, IP-X2 or IPC-AR; 5/8 in. thick Type AR, C, IP-AR, IP-X1, IP-X2, IPC-AR, SCA, SHK, or 3/4 in. thick Type IP-X3 or ULTRACODE

UNITED STATES GYPSUM CO. - Type USGX

USG BORAL ZAWAY DRYWALL L L C SFZ - 1/2 in. Type C, 5/8 in. Types C, SCX

51. Gypsum Board - (Not Shown) - (As an alternate to Item 5) when used as the base layer on one or both sides of wall between 1/2 in. or 5/8 in. thick products as specified. For direct attachment only to steel studs Item 2A, not to be used with Item 3. Nom 5/8 in. or 3/4 in. thick lead backed gypsum panels with beveled, square or tapered edges, applied vertically. Vertical joints centered over studs and staggered one stud cavity on opposite sides of studs. Wallboard secured to studs with 1-1/4 in. long Type S-12 steel screws spaced 16 in. OC, corner and 12 in. OC in the field. Min. voids gypsum panels attached over OSB or plywood panels and fastener lengths for gypsum panels increased by min. 1/2 in.

CGC INC. - 1/2 in. thick Type C, IP-X2 or IPC-AR; 5/8 in. thick Type AR, C, IP-AR, IP-X1, IP-X2, IPC-AR, SCA, SHK, or 3/4 in. thick Type IP-X3 or ULTRACODE

UNITED STATES GYPSUM CO. - Type USGX

USG BORAL ZAWAY DRYWALL L L C SFZ - 1/2 in. Type C, 5/8 in. Types C, SCX

51. Gypsum Board - (Not Shown) - (As an alternate to Item 5) when used as the base layer on one or both sides of wall between 1/2 in. or 5/8 in. thick products as specified. For direct attachment only to steel studs Item 2A, not to be used with Item 3. Nom 5/8 in. or 3/4 in. thick lead backed gypsum panels with beveled, square or tapered edges, applied vertically. Vertical joints centered over studs and staggered one stud cavity on opposite sides of studs. Wallboard secured to studs with 1-1/4 in. long Type S-12 steel screws spaced 16 in. OC, corner and 12 in. OC in the field. Min. voids gypsum panels attached over OSB or plywood panels and fastener lengths for gypsum panels increased by min. 1/2 in.

CGC INC. - 1/2 in. thick Type C, IP-X2 or IPC-AR; 5/8 in. thick Type AR, C, IP-AR, IP-X1, IP-X2, IPC-AR, SCA, SHK, or 3/4 in. thick Type IP-X3 or ULTRACODE

UNITED STATES GYPSUM CO. - Type USGX

USG BORAL ZAWAY DRYWALL L L C SFZ - 1/2 in. Type C, 5/8 in. Types C, SCX



Consultants:

MEP:

Collaborative Engineering Group
8904 Fairbanks N. Houston Suite 201
Houston, TX 77064
T: 281.598.1170
F: 281.598.1130

SUNSET COFFEE

1019 Commerce St.
Houston, TX 77002

Ownership of Instruments of Service:
All reports, plans, specifications, computer files, field data, notes & other documents and instruments prepared by BRAVE / ARCHITECTURE as instruments of service shall remain the property of BRAVE / ARCHITECTURE. BRAVE / ARCHITECTURE shall retain all common law, statutory and other reserved rights, including the copyright thereto.

Issue:

2016.2.17 OWNER FINAL REVIEW
2016.2.23 PERMIT

B/A Project No.: 15137
Drawn By: MM
Checked By: SM
Date:
Scale: AS NOTED

INTERIOR & MILLWORK ELEVATIONS

A.702

- D1.01 Remove existing partition/wall. Remove existing finish construction back to existing base building structure. Clean and prepare to receive new construction. Contractor to maintain structural integrity of building.
- D1.03 Remove and relocate door, hardware and frame where indicated.
- D1.05 Existing exit sign to remain.
- D1.12 Remove light fixtures
- D1.13 Remove shelving
- D1.14 Remove and relocate fire extinguisher
- D1.15 Existing column to remain. All existing structure to remain.
- D1.16 Existing storefront to remain.
- D1.17 Existing door and hardware to remain
- D1.18 Existing window to remain.
- D1.25 Existing balcony and railing to remain.
- D1.26 Existing concrete slab to remain.
- D1.27 Existing restrooms to remain.
- D1.28 Existing janitor room to remain.
- D1.29 Existing elevator to remain.
- D1.30 Existing exterior walkway to remain.
- D1.31 Existing light fixture to remain.
- D1.32 Existing stairs to remain.
- 1.03 Scheduled door
- 1.04 Scheduled partition
- 1.05 Custom Millwork, Re: Millwork
- 1.17 Scheduled light fixture, Re: Electrical
- 1.23 Fire extinguisher
- 1.32 Custom glass display, Re: Millwork
- 1.33 Custom rope "screen". Rope by owner, installed by GC. Re: Millwork
- 1.34 Fixed panel with in-counter adjustable cup dispensers. Dispense-Rite ADJ-2
- 1.35 Furniture - OFOI
- 1.36 Custom Wall Shelf, Re: Millwork
- 1.40 S.S. sink, Re: MEP
- 1.45 S.S. Hand sink, Re: MEP
- 1.48 Existing Structure
- 1.49 Existing three compartment sink
- 1.50 Shelving system.
- 1.51 Steel bracket
- 1.52 Cup dispenser, Dispense Rite ADJ-2 (typ.) S.S.
- 1.53 Knock Chute, S.S. 6" x 5.5" x 4" Espresso Supply Inc. 6" S.S. grammet
- 1.54 2x6 Wood slot ceiling @ 10'-0" A.F.F.
- 2.01 Gyp. board ceiling @ 8'-6" A.F.F.
- 2.02 Salvaged rope installation
- 2.03 Slat wood ceiling hung with Unistrut @ 48" O.C. max.
- 2.04 Stained wood shelves with black steel brackets
- 2.05 Stained wood shelves with internal steel support
- 2.06

KEY NOTES

- IE1. Refer to General sheets for typical graphic, symbols, abbreviation index, and "Master Keynote" list.
- IE2. Refer to Texas Accessibility Guidelines sheet(s).
- IE3. All horizontal dimensions are provided on plans, and all vertical dimensions are provided on elevations and/or sections unless otherwise noted.
- IE4. Provide adequate blocking as required at every location where millwork, wall light fixtures, TV brackets, plumbing fixtures, etc., are to be mounted. Item are required to resist 250 pound point load.
- IE5. There are items shown, i.e. outlets, switches, thermostats, on the MEP drawings that are not drawn on the architectural elevations. Contractor to coordinate and mount all MEP items per architectural sheet A.730 unless noted otherwise.
- IE6. Refer to finish schedule and plans for all finishes unless noted otherwise.
- IE7. All custom millwork, if in scope of work, is shown in elevation and designed per designated details. Refer to interior elevations, millwork details, and specifications divisions 06000 and/or division 12000.
- IE8. All manufacturer casework, if in scope of work, is designated on enlarged floor plans. Refer to casework schedule and specifications division 12000 for detailed information. Contractor is to follow the scheduled manufacturer's specifications, instructions, and recommendations unless directed otherwise by the contract manual.
- IE9. Refer to the equipment schedule for all installed equipment. Equipment is designed on enlarged floor plans.

GENERAL NOTES

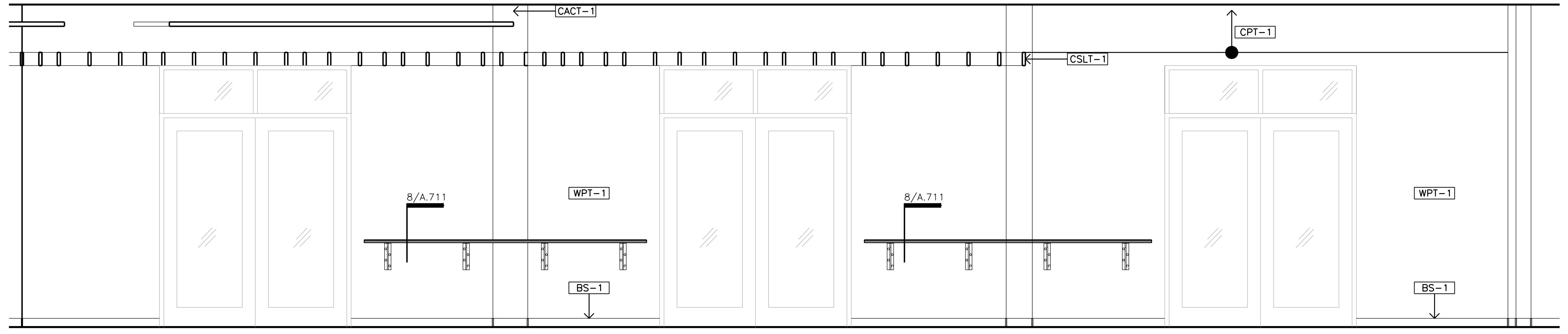
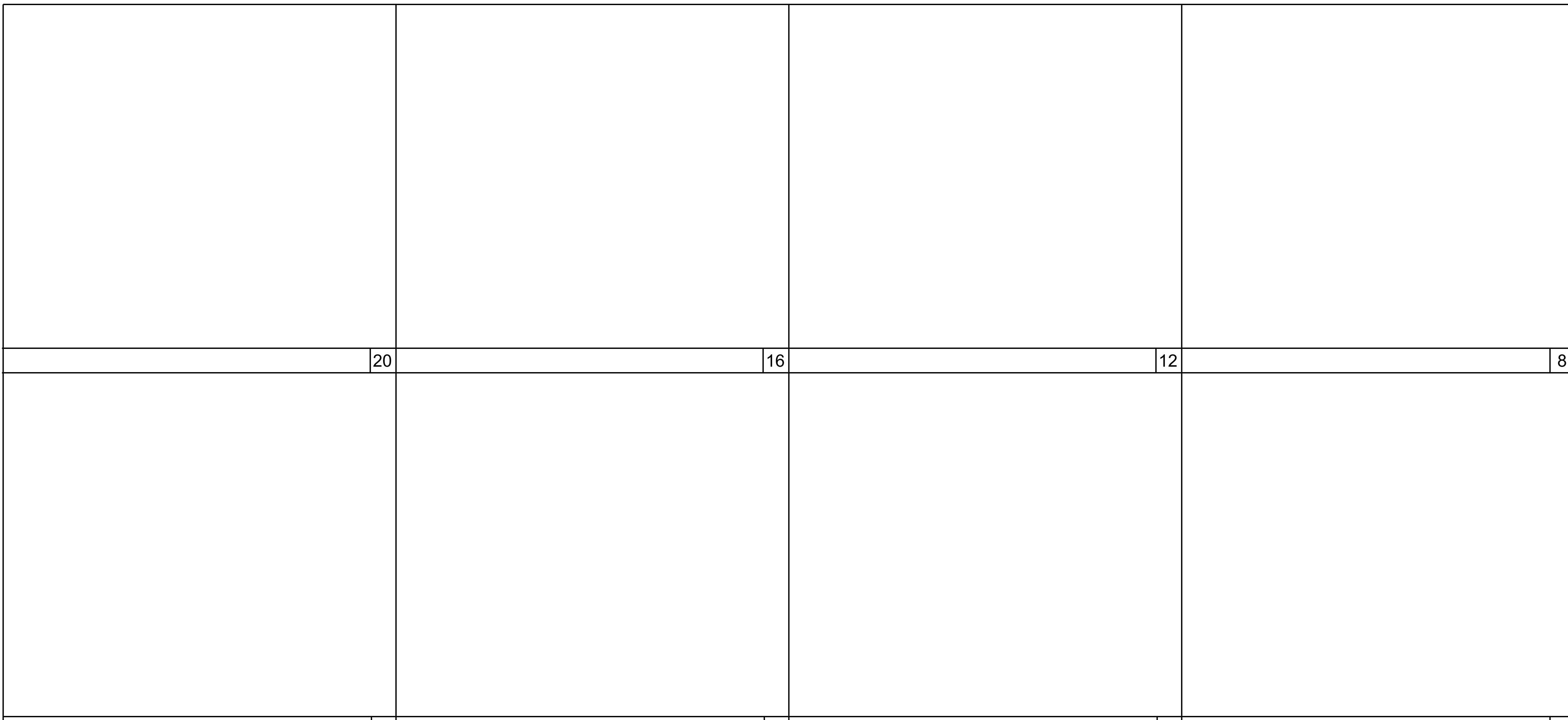

INTERIOR ELEVATION

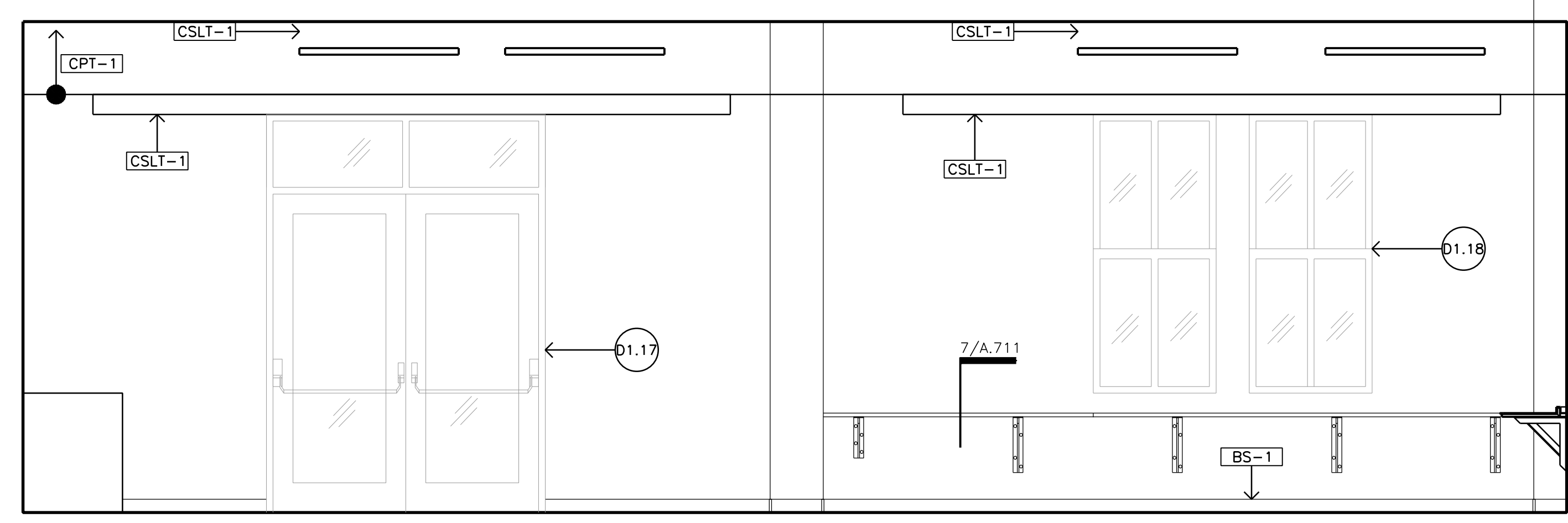

INTERIOR ELEVATION

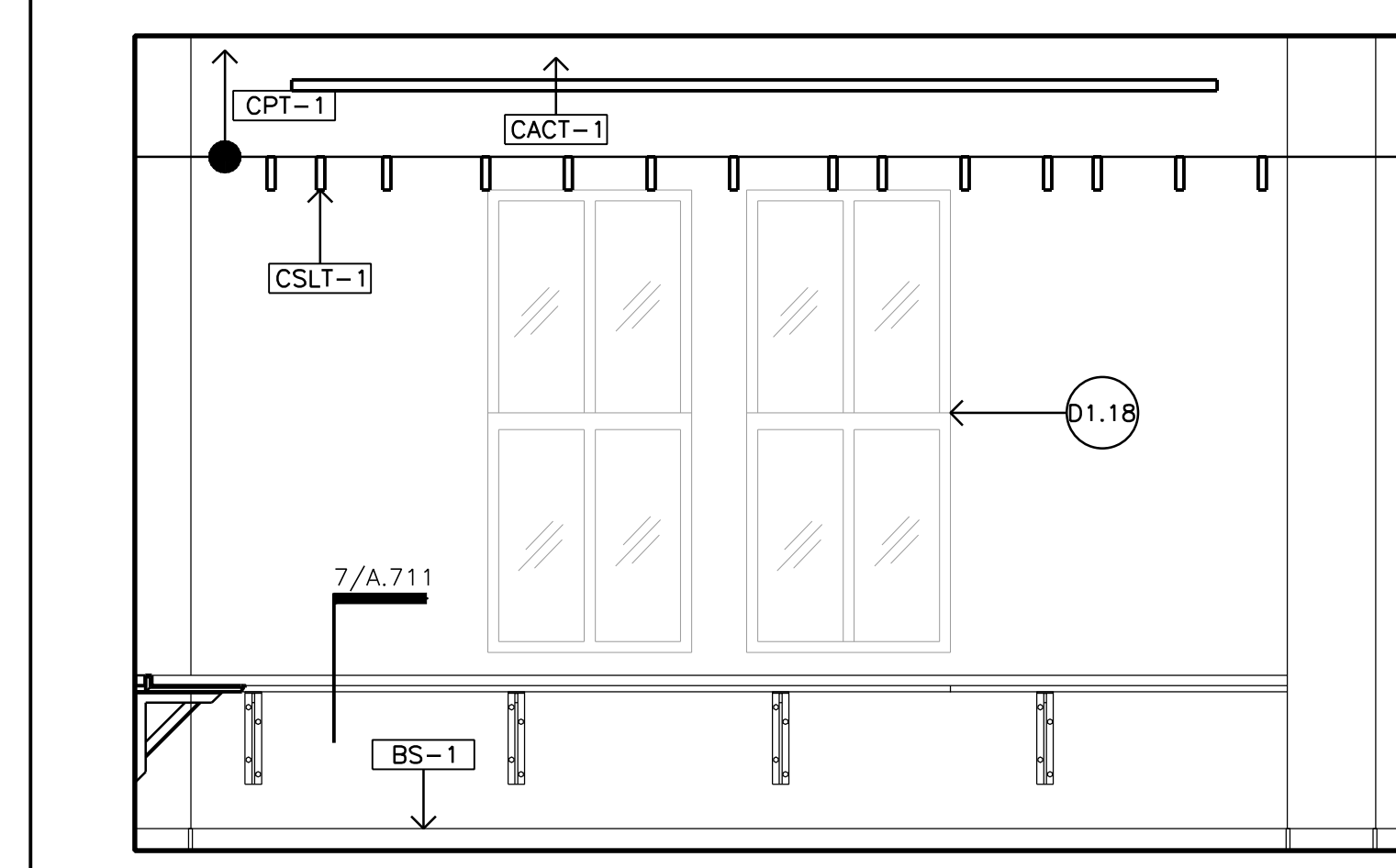

INTERIOR ELEVATION

GENERAL NOTES

MILLWORK HARDWARE				
ACCESSORIES	LOCATION	MANUFACTURER	TYPE	DESCRIPTION
STYLING DRAWERS	ACCURIDE	ACCURIDE	3832TR touch release	
DRAWERS	ACCURIDE	ACCURIDE	3640A	
ALL MILLWORK	IVES	IVES	CL-11 OR CL-12	ADD CL-14 TO ALL LARGE DOORS
STYLING DRAWERS	DOCKING DRAWER	STYLE DRAWER SE		BUILT-IN POWER OUTLET FOR STYLISTS' DRAWERS
CLOSET	KC STORE FIXTURE	-	-	-
CLOSET	KC STORE FIXTURE	-	-	-

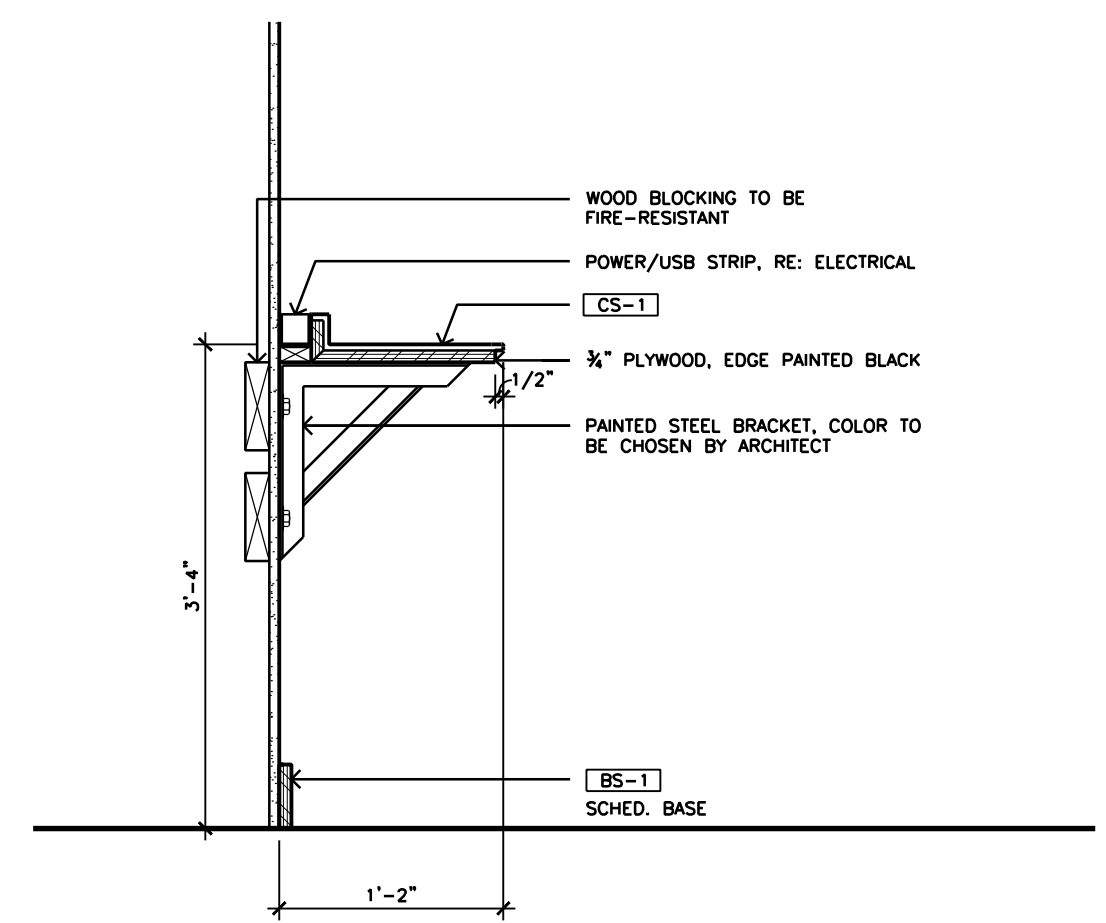

B/A

BRAVE / ARCHITECTURE
 4617 Montrose Blvd., Suite C.230
 Houston, Texas 77006
 Voice: 713.524.5858
 Fax: 713.524.5868
 studio@bravearchitecture.com
 Contact: Silvana Micolich
 smicolich@bravearchitecture.com



XXX N.T.S. 12 MILLWORK DETAIL 1"=1'-0" 8 XXX N.T.S. 4

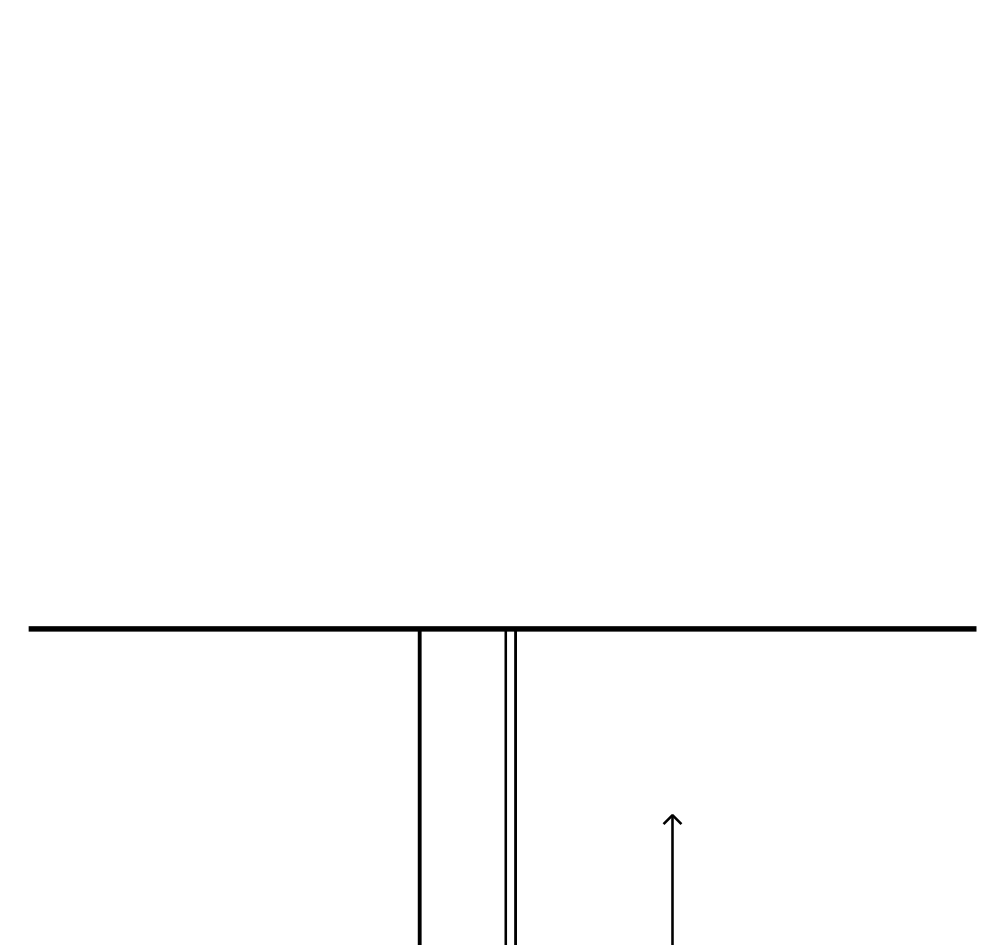
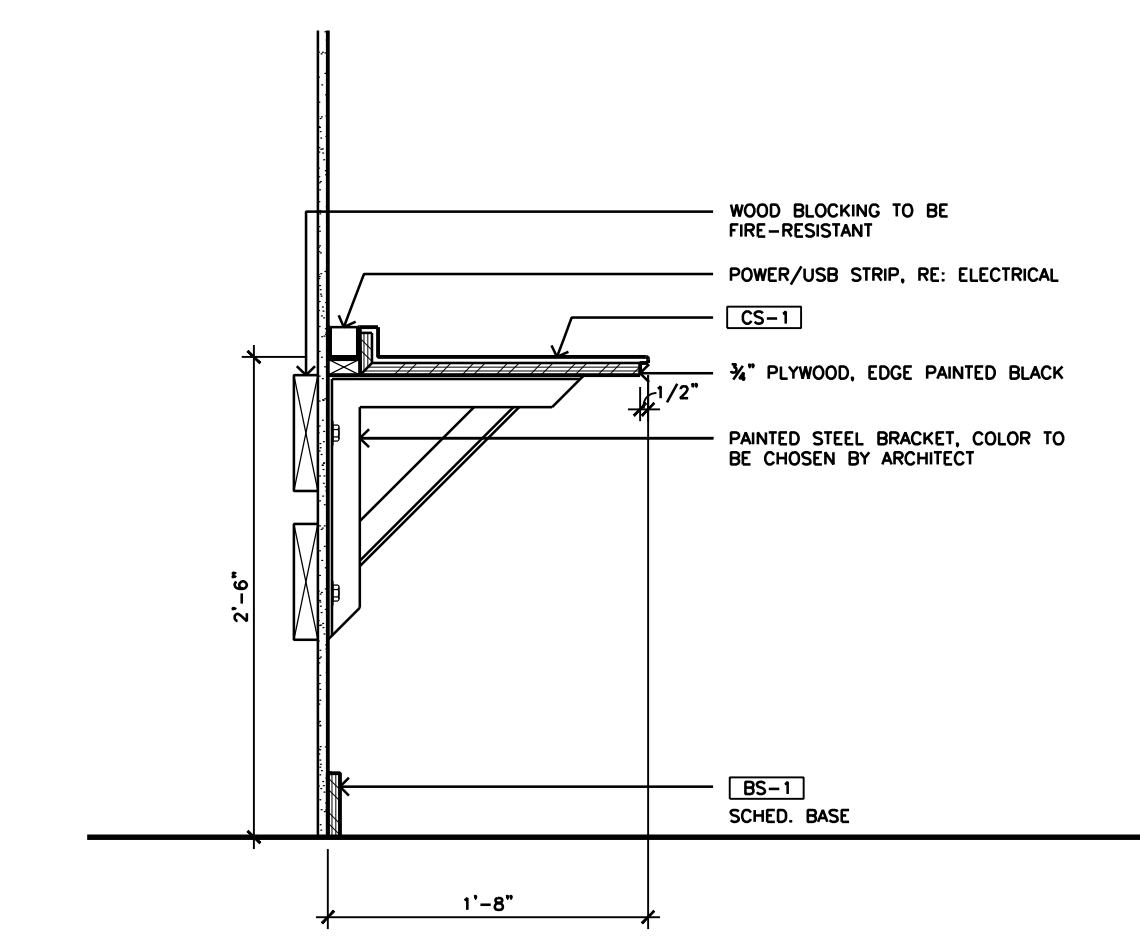
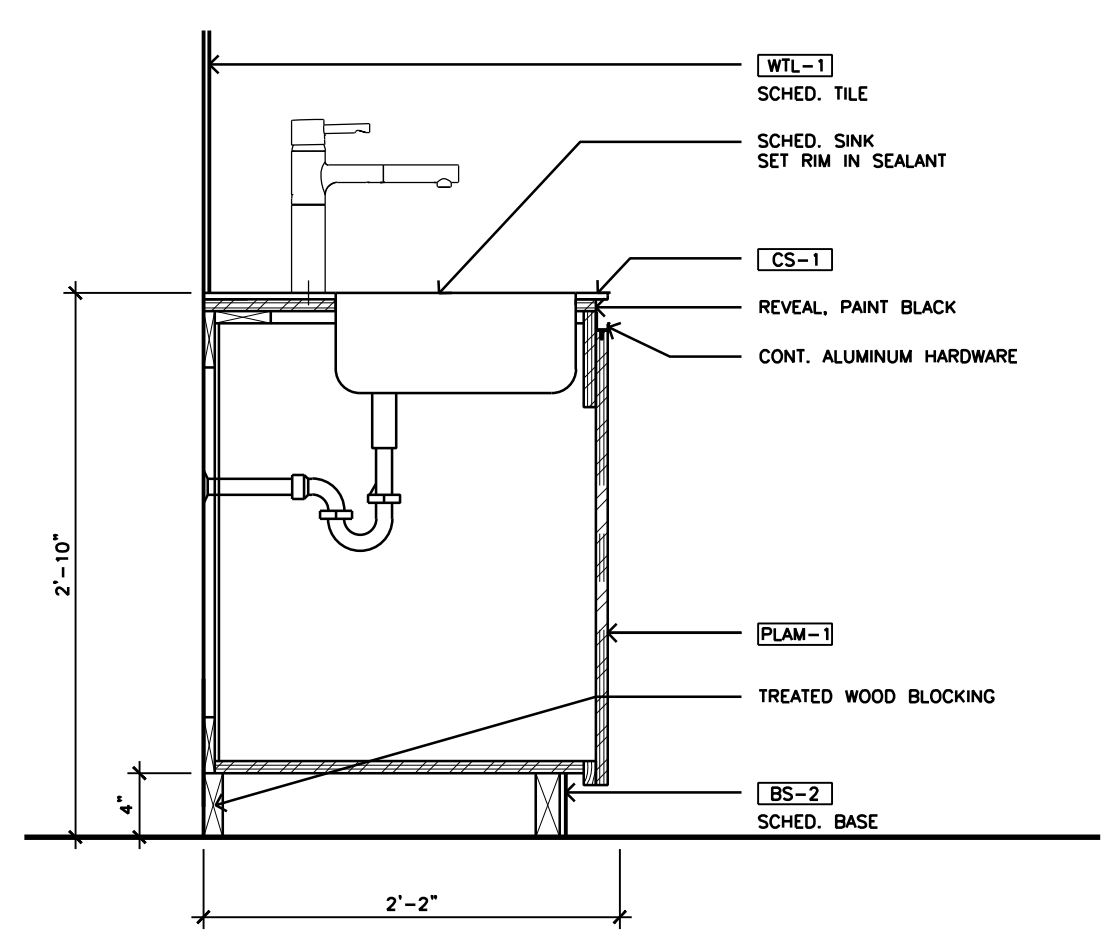
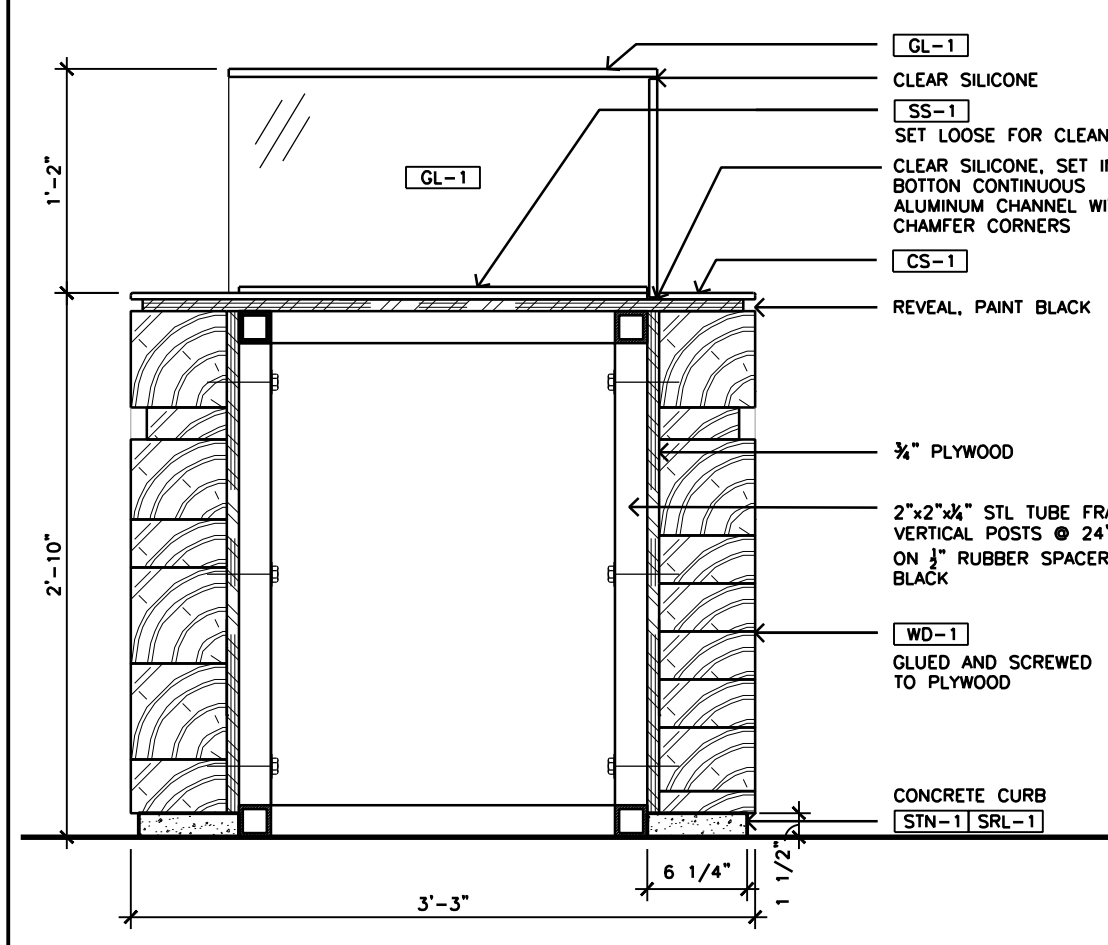

Consultants:
 MEP:
 Collaborative Engineering Group
 8904 Fairbanks N. Houston Suite 201
 Houston, TX 77064
 T: 281.598.1170
 F: 281.598.1130

XXX N.T.S. 19 MILLWORK DETAIL 1"=1'-0" 15 MILLWORK DETAIL 1"=1'-0" 11 MILLWORK DETAIL 1"=1'-0" 7

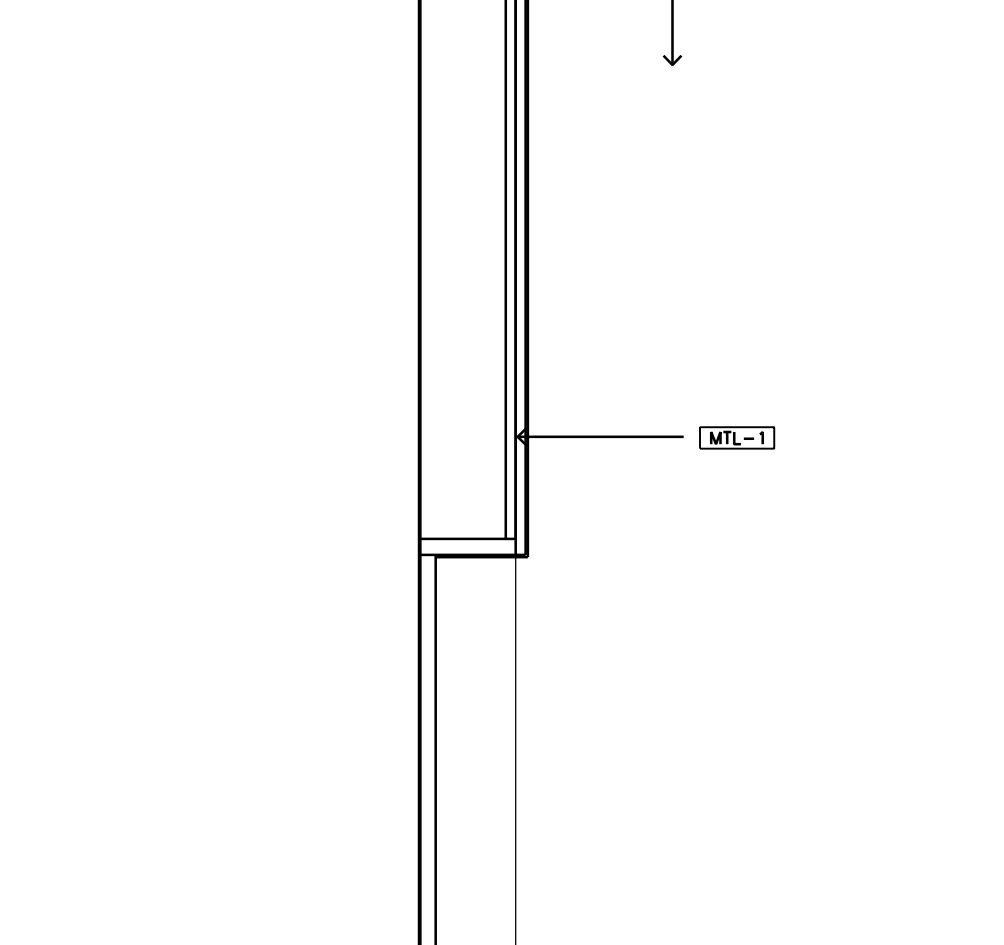
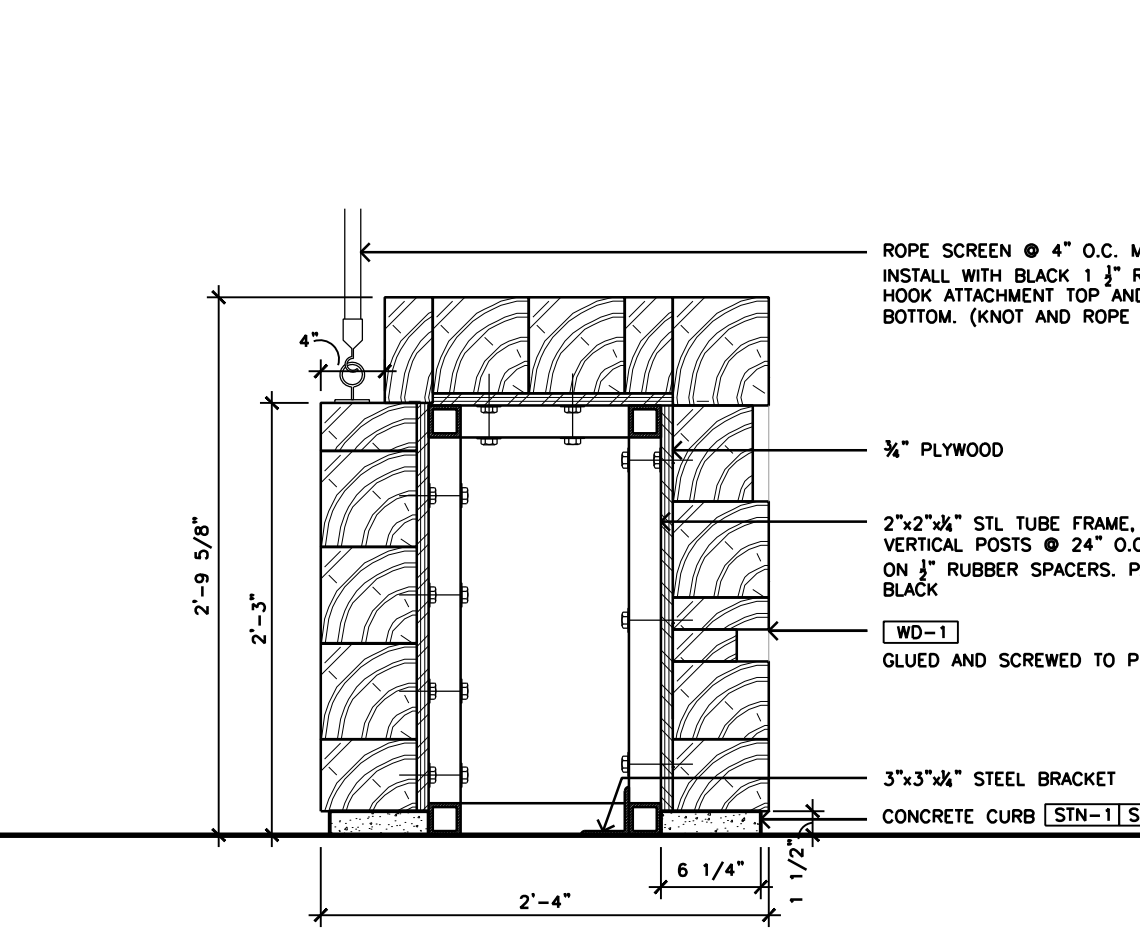
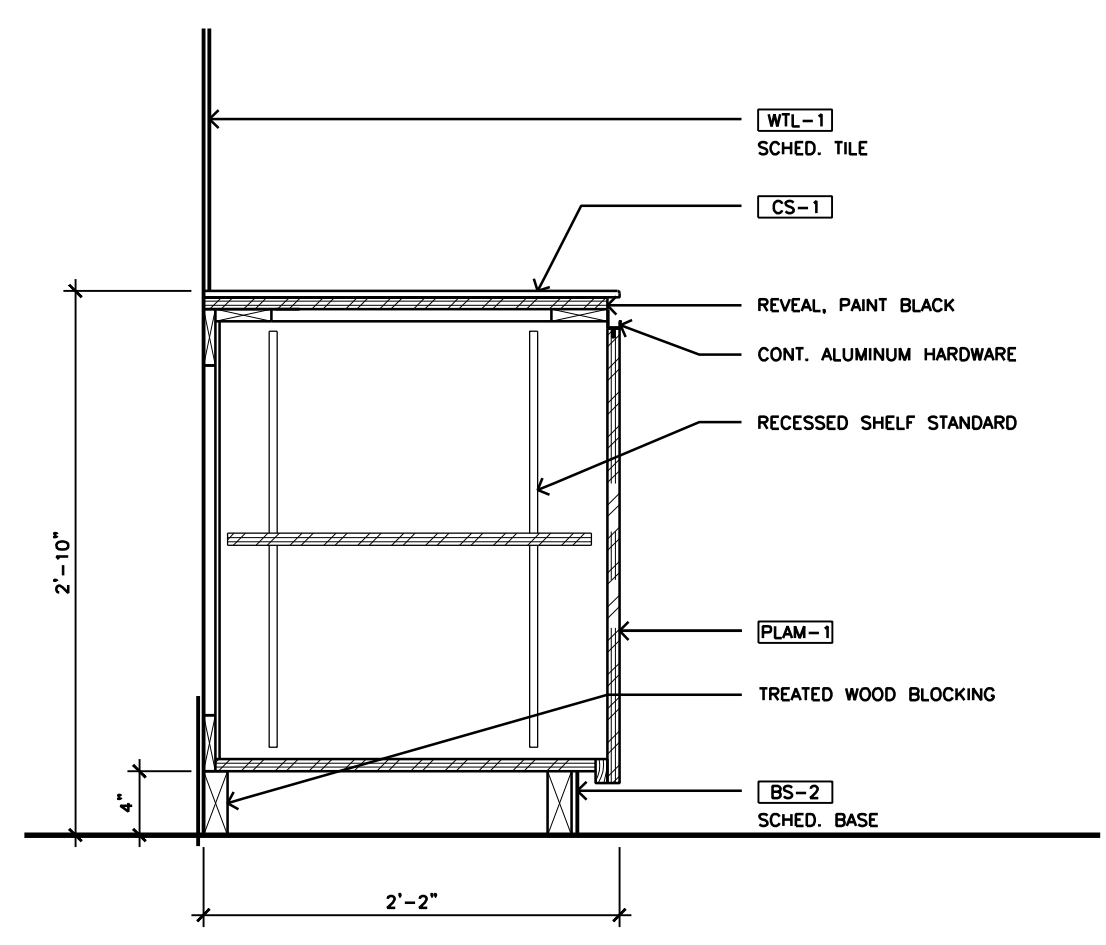
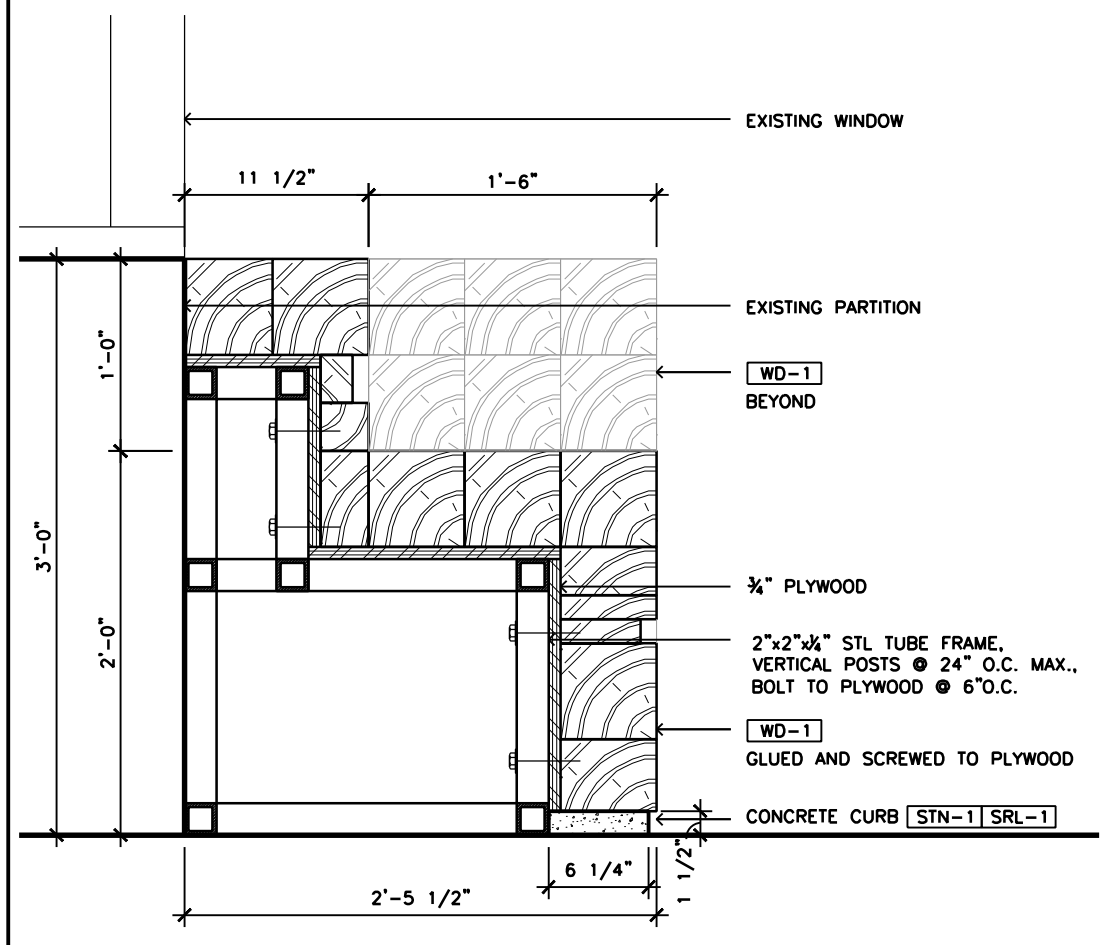

SUNSET COFFEE
 1019 Commerce St.
 Houston, TX 77002

Ownership of Instruments of Service:
 All reports, plans, specifications, computer files, field data, notes & other documents and instruments prepared by BRAVE / ARCHITECTURE as instruments of service shall remain the property of BRAVE / ARCHITECTURE. BRAVE / ARCHITECTURE shall retain all common law, statutory and other reserved rights, including the copyright thereto.

XXX N.T.S. 18 MILLWORK DETAIL 1"=1'-0" 14 MILLWORK DETAIL 1"=1'-0" 10 MILLWORK DETAIL 1"=1'-0" 6

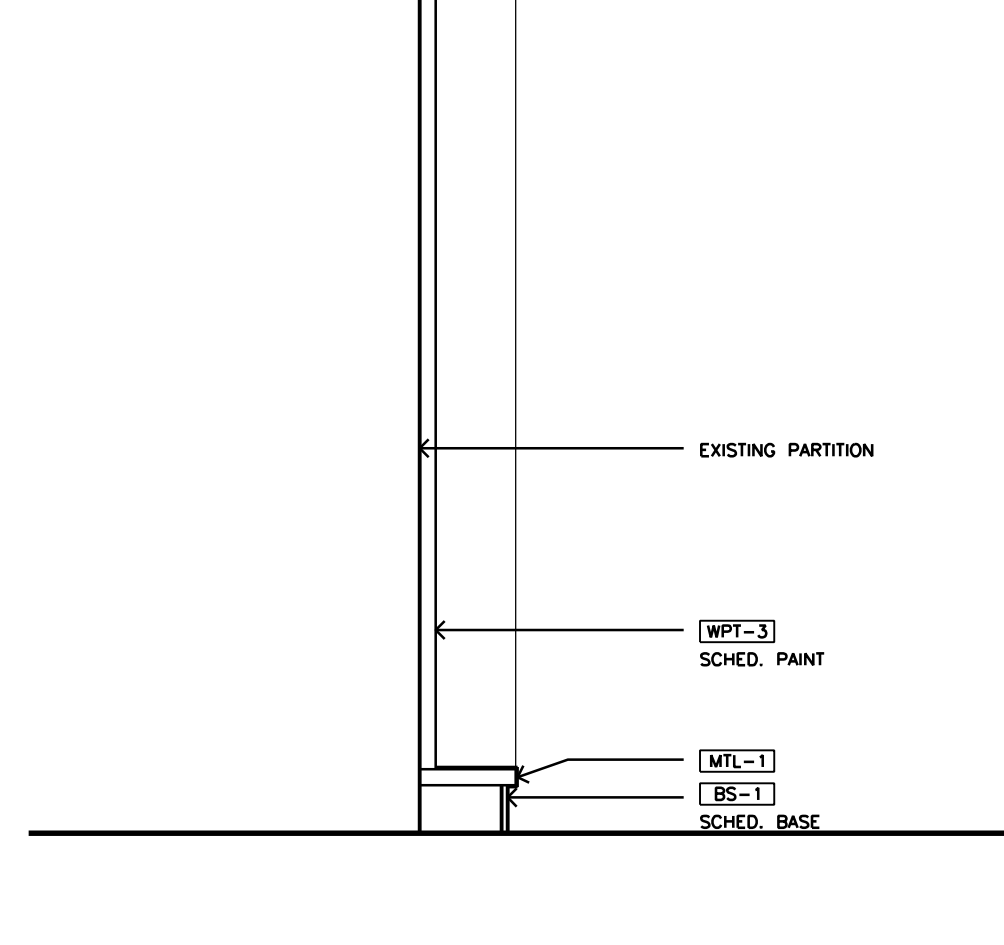
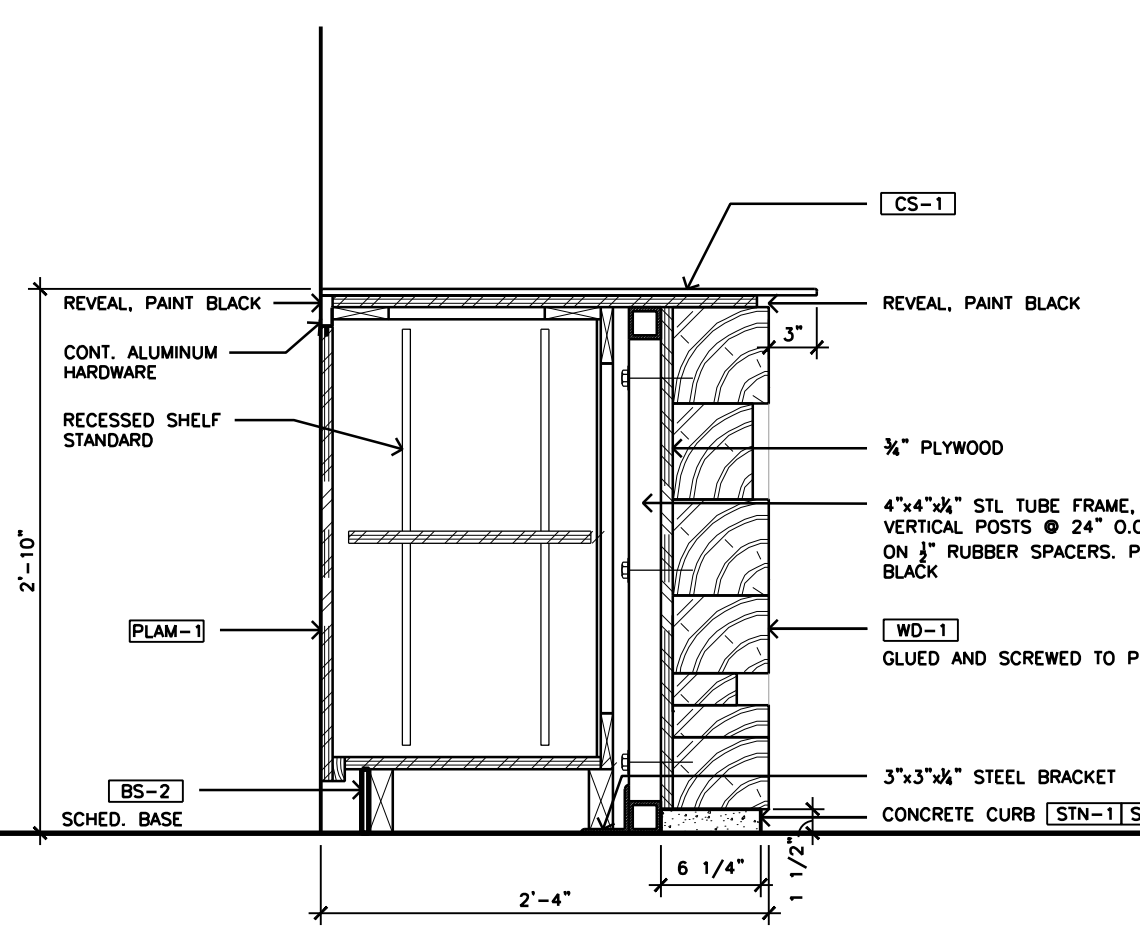
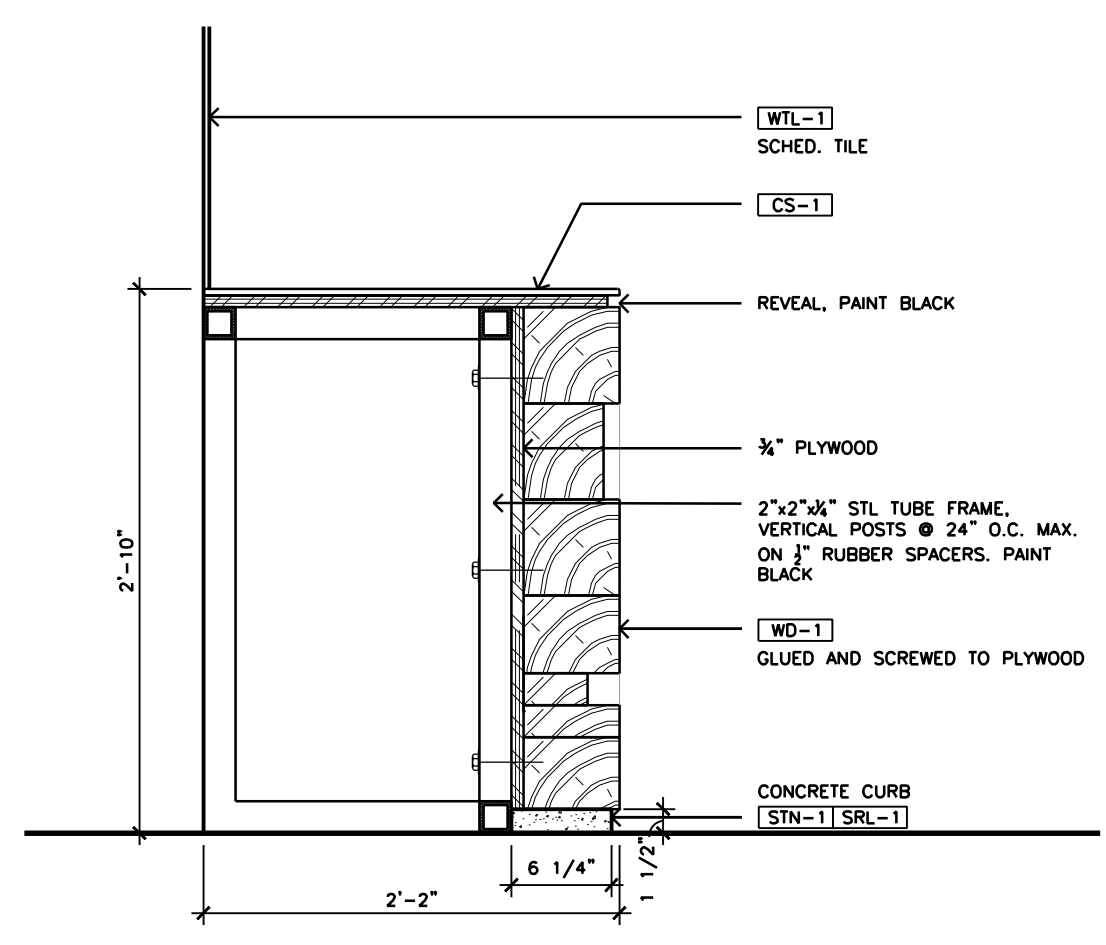
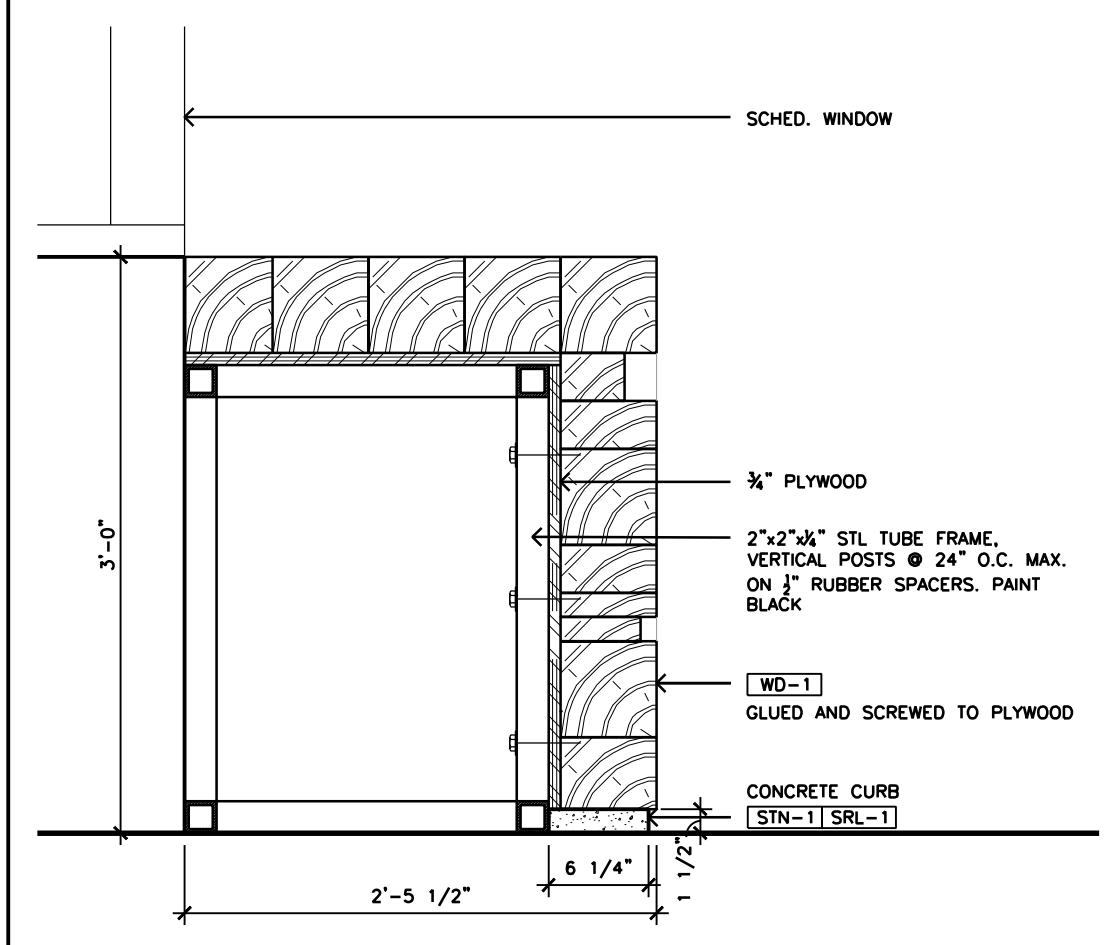
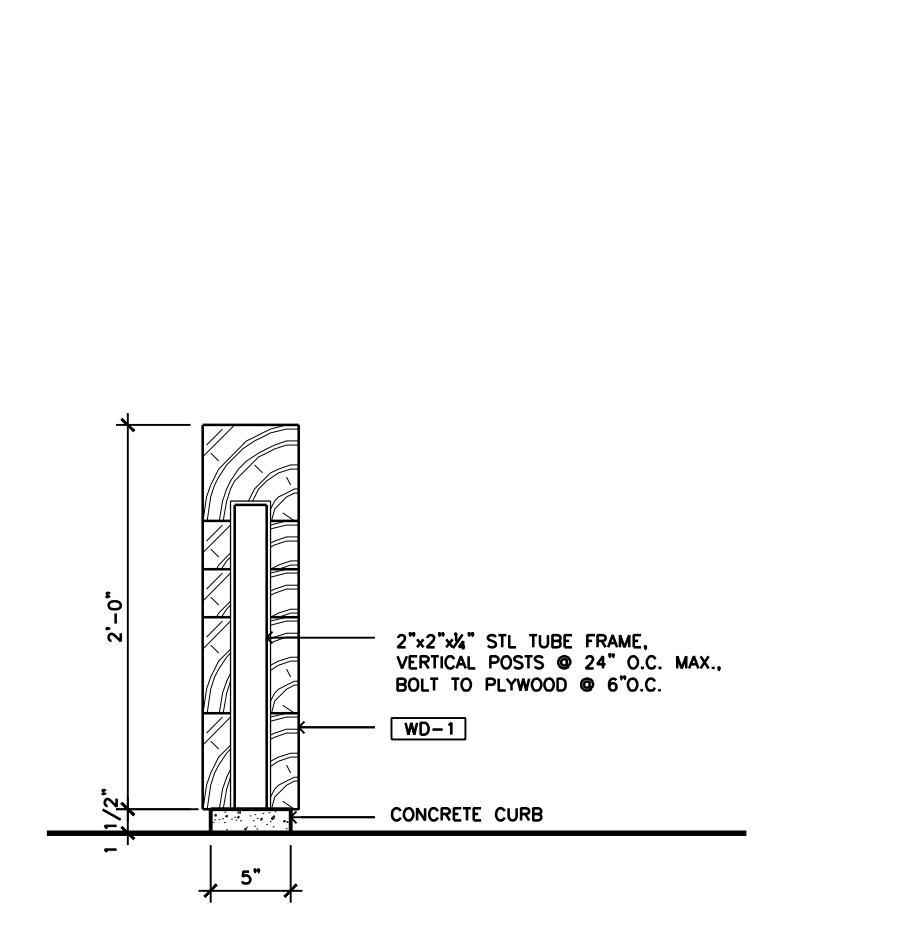

Issue:
 2016.2.17 OWNER FINAL REVIEW
 2016.2.23 PERMIT

B/A Project No.: 15137
 Drawn By: MM
 Checked By: SM
 Date:
 Scale: AS NOTED

MILLWORK DETAIL 1"=1'-0" 17 MILLWORK DETAIL 1"=1'-0" 13 MILLWORK DETAIL 1"=1'-0" 9 MILLWORK DETAIL 1"=1'-0" 5 MILLWORK DETAIL 1"=1'-0" 1

MILWORK DETAILS

A.711



F. Brava
4 MAY 2016

Consultants:

MEP:

Collaborative Engineering Group
8904 Fairbanks N. Houston Suite 201
Houston, TX 77064
T: 281.598.1170
F: 281.598.1130

SUNSET COFFEE

1019 Commerce St.
Houston, TX 77002

Ownership of Instruments of Service:
All reports, plans, specifications, computer files, field data, notes & other documents and instruments prepared by BRAVE / ARCHITECTURE as instruments of service shall remain the property of BRAVE / ARCHITECTURE. BRAVE / ARCHITECTURE shall retain all common law, statutory and other reserved rights, including the copyright thereto.

Issue:

2016.2.17 OWNER FINAL REVIEW
2016.2.23 PERMIT
2016.5.4 PERMIT COMMENTS

B/A Project No.: 15137
Drawn By: MM
Checked By: SM
Date:
Scale: AS NOTED

DOOR TYPES, SCHEDULE & DETAILS

NOT USED		NOT USED		NOT USED		NOT USED		NOT USED																																																																																		
NOT USED	20	NOT USED	16	NOT USED	12	NOT USED	8	NOT USED	4																																																																																	
		<p>20 20 MINUTE RATING HC HOLLOW CORE HM HOLLOW METAL</p> <p>A CLASS A (3 HOUR) LE LOW-E FLOAT GLASS LG LAMINATED GLASS LT LOW-E TEMP. GLASS</p> <p>B CLASS B (1 1/2 HOUR) LE LOW-E FLOAT GLASS LG LAMINATED GLASS LT LOW-E TEMP. GLASS</p> <p>C CLASS C (3/4 HOUR) NL NARROW LITE</p> <p>AL ALUMINUM PF PRE-FINISHED BR BRONZE PL PLASTIC LAMINATE PT PAINTED</p> <p>CA CLEAR ANODIZED SP SPANDREL GLASS CB CEMENT BOARD SS STAINLESS STEEL CD CEDAR ST STAINED STEEL</p> <p>ED ELEVATOR DOOR THR THRESHOLD ET ETCHED</p> <p>FG FULL GLAZED W W FR FROSTED GLASS - FROSTED & TEMP. WOOD FT GLASS - FROSTED & TEMP. WSTR WEATHER STRIP WD WOOD GL GLASS - FLOAT, CLEAR WDHC WOOD HOLLOW CORE GR GLASS-RATED WDC WOOD SOLID CORE GT GLASS - TEMPERED, CLEAR GSTL GALVANIZED STEEL</p> <p>HW SET: 01 DOOR NUMBERS: D.002 EACH TO HAVE: 4 EA HINGE 5BB1 4.5 X 4.5 626 IVE 1 EA MULTI-FUNCTION LOCK 70-MLB205 LP 626 SAR 1 EA MORTISE CYLINDER 1E74 X RP3 626 BES 1 EA HOLDER/STOP 690 SERIES SAR 1 EA KICK PLATE 8400 10" X 2" LDW 630 IVE 4 EA SILENCER SR 64 GRY IVE</p> <p>HW SET: 02 DOOR NUMBERS: D.003 EACH TO HAVE: 4 EA HINGE 5BB1 4.5 X 4.5 626 IVE 1 EA MULTI-FUNCTION LOCK 70-MLB205 LP 626 SAR 1 EA MORTISE CYLINDER 1E74 X RP3 626 BES 1 EA HOLDER/STOP 690 SERIES SAR 1 EA KICK PLATE 8400 10" X 2" LDW 630 IVE 4 EA SILENCER SR 64 GRY IVE</p> <p>HW SET: 03 DOOR NUMBERS: D.004 EACH TO HAVE: 4 EA HINGE 5BB1 4.5 X 4.5 626 IVE 1 EA CLOSER 1460 SERIES LCN 1 EA KICK PLATE 8400 10" X 2" LDW 630 IVE 1 EA PUSH PLATE 8200 6"x16" 630 IVE 1 EA PULL PLATE 8300 6"x16" 630 IVE 1 EA PULL 8102 10" CENTERS 630 IVE 4 EA SILENCER SR 64 GRY IVE</p> <p>ALL LOCKS TO RECEIVE SEVEN PIN CORE LOCKING FUNCTION. GC TO COORDINATE WITH OWNER.</p>		<p>19 TYP. HM DOOR HEAD</p>		<p>15 DOOR SCHEDULE ABBREVIATIONS</p>		<p>11 DOOR HARDWARE SCHEDULE</p>		3																																																																																
		<p>18 TYP. HM DOOR JAMB</p>		<p>14</p>		<p>10 DOOR TYPES, HEIGHTS, & CLEARANCES</p>		N.T.S. 2																																																																																		
		<p>17 TYP. HM DOOR JAMB</p>		<p>13 DOOR AND FRAME SCHEDULE</p> <table border="1"> <thead> <tr> <th rowspan="2">DOOR MARK</th> <th rowspan="2">DOOR LOCATION</th> <th rowspan="2">DOOR SIZE (W x H)</th> <th rowspan="2">DOOR ELEV.</th> <th rowspan="2">DOOR MAT.</th> <th rowspan="2">DOOR FINISH</th> <th rowspan="2">FRAME SIZE (W x H)</th> <th rowspan="2">RATING</th> <th rowspan="2">FRAME MATL.</th> <th rowspan="2">FRAME FINISH</th> <th colspan="3">DETAILS</th> <th rowspan="2">HW SET</th> <th rowspan="2">GLASS TYPE</th> <th rowspan="2">NOTE(S)</th> </tr> <tr> <th>HEAD</th> <th>JAMB</th> <th>SILL</th> </tr> </thead> <tbody> <tr> <td>D.001</td> <td>WORK ROOM</td> <td>EXISTING</td> <td>-</td> <td>-</td> <td>-</td> <td>-</td> <td>60 MIN</td> <td>-</td> <td>-</td> <td>-</td> <td>-</td> <td>-</td> <td>EXIST.</td> <td>-</td> <td>RELOCATE EXISTING</td> </tr> <tr> <td>D.002</td> <td>DISPLAY</td> <td>3'-0" x 7'-0"</td> <td>A</td> <td>HM</td> <td>D.PT.1</td> <td>3'-4" x 7'-2"</td> <td>-</td> <td>HM</td> <td>D.PT.1</td> <td>15/A.820</td> <td>14/A.820</td> <td>-</td> <td>01</td> <td>-</td> <td>MATCH EXISTING DOORS</td> </tr> <tr> <td>D.003</td> <td>BAR</td> <td>3'-0" x 7'-0"</td> <td>A</td> <td>HM</td> <td>D.PT.1</td> <td>3'-4" x 7'-2"</td> <td>-</td> <td>HM</td> <td>D.PT.1</td> <td>15/A.820</td> <td>14/A.820</td> <td>-</td> <td>02</td> <td>-</td> <td>MATCH EXISTING DOORS</td> </tr> <tr> <td>D.004</td> <td>CORRIDOR</td> <td>3'-0" x 7'-0"</td> <td>B</td> <td>HM</td> <td>D.PT.1</td> <td>3'-4" x 7'-2"</td> <td>-</td> <td>HM</td> <td>D.PT.1</td> <td>15/A.820</td> <td>14/A.820</td> <td>-</td> <td>03</td> <td>GL.1</td> <td>MATCH EXISTING DOORS</td> </tr> </tbody> </table> <p>GL-1: 1/4" TEMPERED CLEAR GLASS</p>		DOOR MARK	DOOR LOCATION	DOOR SIZE (W x H)	DOOR ELEV.	DOOR MAT.	DOOR FINISH	FRAME SIZE (W x H)	RATING	FRAME MATL.	FRAME FINISH	DETAILS			HW SET	GLASS TYPE	NOTE(S)	HEAD	JAMB	SILL	D.001	WORK ROOM	EXISTING	-	-	-	-	60 MIN	-	-	-	-	-	EXIST.	-	RELOCATE EXISTING	D.002	DISPLAY	3'-0" x 7'-0"	A	HM	D.PT.1	3'-4" x 7'-2"	-	HM	D.PT.1	15/A.820	14/A.820	-	01	-	MATCH EXISTING DOORS	D.003	BAR	3'-0" x 7'-0"	A	HM	D.PT.1	3'-4" x 7'-2"	-	HM	D.PT.1	15/A.820	14/A.820	-	02	-	MATCH EXISTING DOORS	D.004	CORRIDOR	3'-0" x 7'-0"	B	HM	D.PT.1	3'-4" x 7'-2"	-	HM	D.PT.1	15/A.820	14/A.820	-	03	GL.1	MATCH EXISTING DOORS	1	
DOOR MARK	DOOR LOCATION	DOOR SIZE (W x H)	DOOR ELEV.	DOOR MAT.	DOOR FINISH											FRAME SIZE (W x H)	RATING	FRAME MATL.				FRAME FINISH	DETAILS			HW SET	GLASS TYPE	NOTE(S)																																																														
						HEAD	JAMB	SILL																																																																																		
D.001	WORK ROOM	EXISTING	-	-	-	-	60 MIN	-	-	-	-	-	EXIST.	-	RELOCATE EXISTING																																																																											
D.002	DISPLAY	3'-0" x 7'-0"	A	HM	D.PT.1	3'-4" x 7'-2"	-	HM	D.PT.1	15/A.820	14/A.820	-	01	-	MATCH EXISTING DOORS																																																																											
D.003	BAR	3'-0" x 7'-0"	A	HM	D.PT.1	3'-4" x 7'-2"	-	HM	D.PT.1	15/A.820	14/A.820	-	02	-	MATCH EXISTING DOORS																																																																											
D.004	CORRIDOR	3'-0" x 7'-0"	B	HM	D.PT.1	3'-4" x 7'-2"	-	HM	D.PT.1	15/A.820	14/A.820	-	03	GL.1	MATCH EXISTING DOORS																																																																											

HVAC ABBREVIATIONS

%	PERCENT
A/C	AIR CONDITIONING
ABV	ABOVE
AD	AUTOMATIC DAMPER
ADR	ACCESS DOOR
AFF	ABOVE FINISHED FLOOR
AFG	ABOVE FINISHED GRADE
AMB	AMBIENT
AMCA	AIR MOVING AND CONDITIONING ASSOC., INC.
AP	ACCESS PANEL
AUX	AUXILIARY
AV	AIR VENT
AVG	AVERAGE
B & S	BELL-AND-SPIGOT
BAS	BUILDING AUTOMATION SYSTEM
BD	BACK DRAFT DAMPER
BOD	BOTTOM OF DUCT
BOP	BOTTOM OF PIPE
BTU	BRITISH THERMAL UNIT(S)
CAP	CAPACITY
CD	CONDENSATE DRAIN
CFH	CUBIC FEET PER HOUR
CFM	CUBIC FEET PER MINUTE
CO	CLEANOUT
CR	CONDENSER RETURN
CS	CONDENSER SUPPLY
CU FT	CUBIC FEET
D	DRAIN
DB	DRY BULB
dB	DECIBEL
DC	DIRECT CURRENT/DRAIN COCK
DDC	DIRECT DIGITAL CONTROL
DEF	DEFLECTION
DEG	DEGREE
DIM	DIGITAL INTERFACE MODULE/DIMENSION
DN	DOWN
DR	DRAIN
EA	EXHAUST AIR
EAT	ENTERING AIR TEMPERATURE
EDB	ENTERING DRY BULB
EER	ENERGY EFFICIENCY RATIO
EFF	EFFICIENCY
EJ	EXPANSION JOINT
ENT	ENTERING
EQ	EQUAL
EQUIP	EQUIPMENT
ER	EXHAUST REGISTER
ESP	EXTERNAL STATIC PRESSURE
EVAP	EVAPORATOR
EWB	ENTERING WET BULB
EWG	ELECTRIC WATER COOLER
EWI	ENTERING WATER TEMPERATURE
EXH	EXHAUST
EXST	EXISTING
EXT	EXTERNAL
FCO	FLOOR CLEANOUT
FIG	FIGURE
FIN. FLR.	FINISH FLOOR
FLA	FULL LOAD AMP
FLR	FLOOR
FM	FLOW METER
FO	FAIL-OPEN
FOB	FLAT ON BOTTOM
FOT	FLAT ON TOP
FPI	FINS PER INCH
FPM	FEET PER MINUTE
FPS	FEET PER SECOND
FRH	FLOOR RADIANT HEATER
FS	FLOW SWITCH
FT	FEET
FT H2O	FEET OF WATER
FT HD	FEET OF HEAD
FT WC	FEET WATER COLUMN
FTR	FIN TUBE RADIATOR
FV	FLOW VALVE
FVNR	FULL VOLTAGE-NON REVERSING
GA	GAUGE
GALV	GALVANIZED
GPH	GALLONS PER HOUR
GPM	GALLONS PER MINUTE
GPS	GALLONS PER SECOND
H	HEIGHT
H2O	WATER
HC	HEATING COIL
HP	HORSEPOWER
HR	HOUR
HTG	HEATING
HTR	HEATER
HVAC	HEATING, VENTILATING AND AIR CONDITIONING
HZ	HERTZ
ID	INSIDE DIAMETER
IN	INCHES
IN H2O	INCHES OF WATER
IN WC	INCHES WATER COLUMN
INC	INCORPORATED
INHg	INCHES OF MERCURY
INSUL	INSULATION
KVA	KILVOLT AMPS
KW	KILOWATT
L	LENGTH
LAT	LEAVING AIR TEMPERATURE
LB	POUND
LBS	POUNDS
LBS/HR	POUNDS PER HOUR
LF	LINEAR FEET
LP	LOW PRESSURE
LV	LEVEL VALVE
LWT	LEAVING WATER TEMPERATURE
MAN	MANUAL
MAT	MIXED AIR TEMPERATURE
MAX	MAXIMUM
MBH	THOUSAND BRITISH THERMAL UNITS PER HOUR
MD	MOTOR DAMPER
MD	MANUAL DAMPER
MFG	MANUFACTURER
MIN	MINIMUM

HVAC ABBREVIATIONS

NC	NORMALLY CLOSED
NF	NON-FUSED
NIC	NOT IN CONTRACT
NK	NECK
NO	NORMALLY OPEN
NOM	NOMINAL
NPHP	NAME PLATE HORSEPOWER
NPS	NOMINAL PIPE SIZE
NPSH	NET POSITIVE SUCTION HEAD
NTS	NOT TO SCALE
O	OXYGEN
OA	OUTDOOR AIR
OAI	OUTDOOR AIR INTAKE
OAT	OUTDOOR AIR TEMPERATURE
OBD	OPPOSED BLADE DAMPER
OC	ON CENTER
OD	OUTSIDE DIAMETER
OZ	OUNCE
PBD	PARALLEL BLADE DAMPER
PD	PRESSURE DROP
PF	POWER FACTOR
PG	PRESSURE GAUGE
PH	PHASE
PL	PLATE
PNEU	PNEUMATIC
POS	POSITION
PRESS	PRESSURE
PROP	PROPELLER
PRV	PRESSURE REDUCING VALVE/PRESSURE REGULATING VALVE
PS	PIPE SUPPORT
PSID	POUNDS PER SQUARE INCH DIFFERENTIAL
PSIG	POUNDS PER SQUARE INCH GAUGE
PV	PLUG VALVE
R	RISE
RA	RETURN AIR
RAD	RADIUS
RAG	RETURN AIR GRILLE
RAO	RETURN AIR OPENING
RAR	RETURN AIR REGISTER
RCP	REFLECTED CEILING PLAN
RE	REFER
REF	REFERENCE
REQD	REQUIRED
REV	REVISION
RH	RELATIVE HUMIDITY
RL	REFRIGERANT LIQUID
RLA	RUNNING LOAD AMPS
RM	ROOM
ROT	ROTATION
RPM	ROTATIONS PER MINUTE
RS	REFRIGERANT SUCTION
RTR	RETURN
RV	RELIEF VALVE
SA	SUPPLY AIR
SAT	SUPPLY AIR TEMPERATURE
SDT	STANDARD
SEC	SECTION
SENS	SENSIBLE
SEQ	SEQUENCE
SERV	SERVICE
SF	SERVIE FACTOR
SHT	SHEET
SI	INTERNATIONAL SYSTEMS OF UNITS
SOL	SOLENOID
SP	STATIC PRESSURE
SPD	STATIC PRESSURE DROP
SPEC	SPECIFICATIONS
SQ.	SQUARE
SQ. FT.	SQUARE FOOT/FEET
SS	STAINLESS STEEL
STD	STANDARD
STH	STAIC TOTAL HEAD
STL	STEEL
STRUC	STRUCTURE/STRUCTURAL
SUCT	SUCTION
SVH	STATIC VELOCITY HEAD
SW	SWITCH
SWS	SERVICE WATER
T	THROAT
TDH	TOTAL DYNAMIC HEAD
TEMP	TEMPERATURE/TEMPORARY
TEW	TOTAL ENERGY WHEEL
TG	TRANSFER GRILLE
TH	THERMOMETER
THK	THICK
TOE	TOP OF EQUIPMENT
TOP	TOP OF PIPE
TP	TOTAL PRESSURE
TSP	TOTAL STATIC PRESSURE
TYP	TYPICAL
UF	UNDER FLOOR
UH	UNIT HEATER
UNO	UNLESS NOTED OTHERWISE
V	VENT/VOLT
VAC	VACUUM
VEL	VELOCITY
VERT	VERTICAL
VFD	VARIABLE FREQUENCY DRIVE
VOL	VOLUME
VP	VELOCITY PRESSURE
W	WATT/WIDE/WIDTH
W	WITH
W/O	WITHOUT
WB	WET BULB
WC	WATER COLUMN
WG	WATER GAUGE
WMS	WIRE MESH SCREEN
WPD	WATER PRESSURE DROP
WTR	WATER
-	DEGREES
°C	DEGREES CELCIUS
°F	DEGREES FAHRENHEIT
ø	DIAMETER
ΔT	TEMPERATURE DIFFERENCE

HVAC EQUIP. ABBREVIATIONS

AC	AIR CURTAIN
AFMS	AIR FLOW MEASURING STATION
AHU	AIR HANDLING UNIT
B	BOILER
CH	CHILLED WATER
CHP	CHILLED WATER PUMP
CP	CONDENSATE PUMP
CRAC	COMPUTER ROOM AIR CONDITIONER
CT	COOLING TOWER
CVB	CONSTANT VOLUME BOX
CWP	CONDENSER WATER PUMP
DC	DRY COIL
DS	DUCT SILENCER
EF	EXHAUST FAN
ERV	ENERGY RECOVERY VENTILATOR
HC	HEATING COIL
HC-E	HEATING COIL - ELECTRIC
HC-S	HEATING COIL - STEAMER
HC-W	HEATING COIL - WATER
HVU	HEATING AND VENTILATING UNIT
HWP	HOT WATER PUMP
HX	HEAT EXCHANGER
L	LOUVER
MUA	MAKE UP AIR
OAHU	OUTDOOR AIR HANDLING UNIT
PHC	PREHEAT COIL
PTAC	PACKAGED TERMINAL AIR CONDITIONER
RF	RETURN FAN
RFH	RADIANT FLOOR HEAT
RTU	ROOF TOP UNIT
SAF	SUPPLY AIR FAN
SEF	SMOKE EXHAUST FAN
SPF	STAIR PRESSURIZATION FAN
UH	UNIT HEATER
VAV	VARIABLE AIR VOLUME

LEGEND

SYMBOL	DESCRIPTION	SYMBOL	DESCRIPTION
AIR DIFFUSERS GRILLES			
	SUPPLY AIR DIFFUSER		RETURN AIR DIFFUSER
	SUPPLY AIR DIFFUSER (1 - WAY THROW)		EXHAUST AIR GRILLE
	SUPPLY AIR DIFFUSER (2 - WAY THROW)		SUPPLY AIR SIDEWALL DIFFUSER
	SUPPLY AIR DIFFUSER (3 - WAY THROW)		RETURN/EXHAUST AIR SIDEWALL GRILLE
	LINEAR SLOT DIFFUSER		
MISCELLANEOUS HVAC			
	FIRE DAMPER		BACK DRAFT DAMPER
	SMOKE DAMPER		MOTORIZED DAMPER
	FIRE SMOKE DAMPER		SMOKE DETECTOR
	VOLUME DAMPER		THERMOSTAT
	SUPPLY FLOW ARROW		RETURN FLOW ARROW
DUCTWORK			
	EXISTING DUCTWORK TO BE REMOVED		EXISTING DUCTWORK TO REMAIN
	NEW DUCTWORK		FLEXIBLE DUCTWORK
	BRANCH DUCT TAKE OFF		MANUAL VOLUME DAMPER
	RADIUS ELBOW		MITERED ELBOW WITH TURNING VANES
	RECTANGULAR DUCT RADIUS ELBOW		ROUND DUCT ELBOW TURNING UP
	RECTANGULAR DUCT MITERED ELBOW		ROUND DUCT ELBOW TURNING DOWN
	RECTANGULAR SUPPLY DUCT UP/DOWN		ROUND SUPPLY DUCT UP/DOWN
	RECTANGULAR RETURN DUCT UP/DOWN		ROUND RETURN DUCT UP/DOWN
	RECTANGULAR EXHAUST DUCT UP/DOWN		ROUND EXHAUST DUCT UP/DOWN
	DUCT TRANSITION - ONE SIDED		DUCT TRANSITION - TWO SIDED
	TRANSITION (RECTANGULAR TO ROUND)		TRANSITION IN VERTICAL (RECTANGULAR TO ROUND)
	RECTANGULAR DUCT WITH SIZE IN INCHES		ROUND DUCT WITH SIZE IN INCHES

MECHANICAL GENERAL NOTES

- SCOPE OF WORK
 - THE CONTRACTOR IS RESPONSIBLE FOR ALL WORK, MATERIALS, AND LABOR TO SATISFY A COMPLETE WORKING SYSTEM WHETHER SPECIFIED OR IMPLIED.
 - ALL WORK IS TO BE PERFORMED IN STRICT COMPLIANCE WITH 2012 UNIFORM MECHANICAL CODE WITH HOUSTON AMENDMENTS, 2009 INTERNATIONAL ENERGY CONSERVATION CODE, ALL LOCAL CODES, AND ALL OTHER REGULATIONS GOVERNING WORK OF THIS NATURE.
 - THE CONTRACTOR SHALL, BEFORE SUBMITTING ANY PROPOSAL, EXAMINE THE PROPOSED SITE AND SHALL DETERMINE FOR HIMSELF THE CONDITIONS THAT MAY AFFECT THE WORK. NO ALLOWANCE SHALL BE MADE IF THE CONTRACTOR FAILS TO MAKE SUCH EXAMINATIONS.
 - ALL EQUIPMENT AND MATERIALS SHALL BE AS SPECIFIED OR "APPROVED EQUAL" BY THE ENGINEER OR ARCHITECT.
- PERMITS
 - THE CONTRACTOR SHALL SECURE ALL PERMITS OR APPLICATIONS AND PAY ANY AND ALL FEES.
- SHOP DRAWINGS
 - SUBMIT MATERIAL LIST AND SHOP DRAWINGS FOR MAJOR EQUIPMENT TO THE ARCHITECT/ENGINEER FOR APPROVAL. THE CONTRACTOR SHALL SUBMIT ELECTRONIC SHOP DRAWINGS AND THEY SHALL BE CLEARLY LABELED.
- FLEXIBLE TYPE DUCT
 - SHALL BE OF TWO ELEMENT SPIRAL CONSTRUCTION COMPOSED OF A CORROSIVE RESISTANT METAL SUPPORTING SPIRAL AND COATED FABRIC WITH A MINERAL BASE. FLEXIBLE DUCT CONNECTORS SHALL BE LISTED BY UL CLASS 1 DUCTS, AND SHALL HAVE A FLAME SPREAD RATING NOT EXCEEDING 25 AND A SMOKE DEVELOPED RATING NOT EXCEEDING 50.
 - USE OF FLEXIBLE DUCTWORK SHALL BE LIMITED TO NO MORE THAN 6 FEET PER RUN. CONTRACTOR SHALL BE CAREFUL SO AS NOT TO KINK OR COLLAPSE FLEXIBLE DUCT.
- REFRIGERANT PIPING
 - CONTRACTOR SHALL PROVIDE AND INSTALL REFRIGERANT PIPING IN ACCORDANCE WITH THE MANUFACTURER'S RECOMMENDATIONS AND IN SUCH A WAY AS TO BE INCONSPICUOUS AND FREE FROM ANY POSSIBLE CONDENSATION.
- DUCTWORK
 - THE DUCTWORK SHALL BE CONSTRUCTED IN ACCORDANCE WITH THE "SMACNA" APPLICABLE MANUALS. ALL DUCTWORK SHALL BE THE LOW VELOCITY TYPE, UNLESS SPECIFIED OTHERWISE.
 - ALL BRANCH DUCTS TO HAVE VOLUME DAMPERS.
 - ALL DUCT JOINTS TO BE SEALED IN ACCORDANCE WITH "SMACNA" STANDARDS AND ACCEPTED GOOD PRACTICE.
 - ALL DUCT DIMENSIONS SHOWN ARE NET INSIDE VALUES.
- DRAINAGE PIPING (CONDENSATE)
 - SHALL BE ROUTED TO FLOOR DRAIN OR INDIRECT WASTE DRAIN.
- HVAC CONTROLS
 - CONTRACTOR TO SUPPLY AND INSTALL ALL CONTROL WIRING AND 7-DAY PROGRAMMABLE THERMOSTATS AS REQUIRED.
- ELECTRICAL
 - CONTRACTOR TO COORDINATE WITH ELECTRICAL CONTRACTOR FOR LOCATION OF WIRING FOR EACH HVAC UNIT.
- PIPE SUPPORTS
 - ALL PIPE SHALL BE SUPPORTED FROM THE BUILDING STRUCTURE IN A NEAT AND WORKMANLIKE MANNER. THE USE OF WIRE OR METAL STRAP TO SUPPORT PIPES WILL NOT BE PERMITTED. SPACING OF PIPE SUPPORTS SHALL NOT EXCEED 8 FEET FOR ALL PIPING, PLASTIC PIPING TO BE SUPPORTED EVERY 4 FEET.
- MISCELLANEOUS
 - ALL EXTERIOR OPENINGS TO BE PROPERLY CAULKED AND SEALED WITH A SEALANT OF HIGH QUALITY AND LONG LIFE, TO PREVENT INFILTRATION OF OUTSIDE AIR INTO CONDITIONED SPACE.
 - COORDINATE INSTALLATION OF ALL ROOF FLASHING AT ROOF PENETRATION.
 - DO NOT SCALE THIS DRAWING FOR EXACT DIMENSIONS. VERIFY ALL FIGURES, CONDITIONS, AND DIMENSIONS AT THE JOB SITE.
 - THE MECHANICAL PLANS ARE INTENDED TO BE DIAGRAMMATIC AND ARE BASED ON ONE MANUFACTURER'S EQUIPMENT. THEY ARE NOT INTENDED TO SHOW EVERY ITEM IN ITS EXACT LOCATION, THE EXACT DIMENSIONS, OR ALL THE DETAILS OF THE EQUIPMENT. THE CONTRACTOR SHALL VERIFY THE ACTUAL DIMENSIONS OF THE EQUIPMENT PROPOSED TO ENSURE THAT THE EQUIPMENT WILL FIT IN THE AVAILABLE SPACE.
- TESTING AND BALANCING
 - THE HVAC SYSTEM SHALL BE TESTED AND BALANCED BY AN INDEPENDENT AGENCY, UNDER THE SUPERVISION OF A LICENSED PROFESSIONAL ENGINEER. A SEALED TYPE WRITTEN REPORT SHALL BE SUBMITTED TO THE ARCHITECT/ENGINEER FOR REVIEW AND APPROVAL.
- GUARANTEE
 - MATERIALS, EQUIPMENT AND INSTALLATION SHALL BE GUARANTEED FOR A PERIOD OF ONE (1) YEAR FROM DATE OF ACCEPTANCE. DEFECTS WHICH APPEAR DURING THAT PERIOD SHALL BE CORRECTED AT THIS CONTRACTOR'S EXPENSE.
 - FOR THE SAME PERIOD, THE MECHANICAL CONTRACTOR SHALL BE RESPONSIBLE FOR ANY DAMAGE TO PREMISES CAUSED BY DEFECTS IN WORKMANSHIP OR IN THE WORK OR EQUIPMENT FURNISHED AND/OR INSTALLED BY MECHANICAL CONTRACTOR.

LEGEND

SYMBOL	DESCRIPTION	SYMBOL	DESCRIPTION
PLAN TAGS/INDICATORS			
	SECTION INDICATOR SECTION NUMBER ON SHEET SHEET REFERENCE NUMBER		CALLOUT INDICATOR CALLOUT NUMBER ON SHEET SHEET REFERENCE NUMBER
	DIFFUSER/GRILLE TAG M = DIFFUSER DESIGNATION S = SIZE IN INCHES C = AIRFLOW (CFM)		MECHANICAL EQUIPMENT TAG MMM = EQUIPMENT DESIGNATION L = LEVEL X = EQUIPMENT NUMBER
	REVISION TAG		CONNECT NEW TO EXISTING



4617 Montrose Blvd., Suite C.230
Houston, Texas 77006
Voice: 713.524.5858
Fax: 713.524.5868
studio@bravearchitecture.com
Contact: Silvana Micolich
smicolich@bravearchitecture.com



Consultants:

MEP:

Collaborative Engineering Group
8904 Fairbanks N. Houston Suite 201
Houston, TX 77064
T: 281.598.1170
F: 281.598.1130

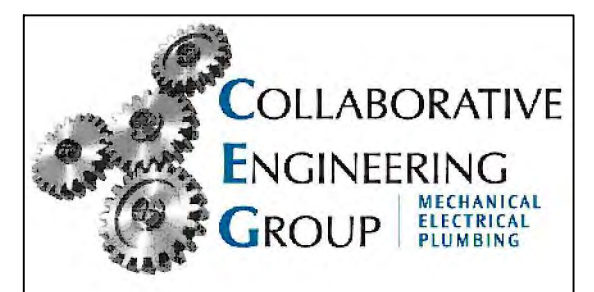

8904 Fairbanks N. Houston, Suite 201
Houston, Texas 77064
281.598.1170
www.collaborative-engr.com
Firm No. F12678

SUNSET COFFEE

1019 Commerce St.
Houston, TX 77002

Ownership of Instruments of Service:
All reports, plans, specifications, computer files, field data, notes & other documents and instruments prepared by BRAVE / ARCHITECTURE as instruments of service shall remain the property of BRAVE / ARCHITECTURE. BRAVE / ARCHITECTURE shall retain all common law, statutory and other reserved rights, including the copyright thereto.

ISSUE:
ISSUE FOR PERMIT 02.25.2016

B/A Project No.: 15137
Drawn By: XX
Checked By: XX
Date:
Scale: AS NOTED

MECHANICAL
SYMBOLS &
ABBREVIATIONS

MO.00

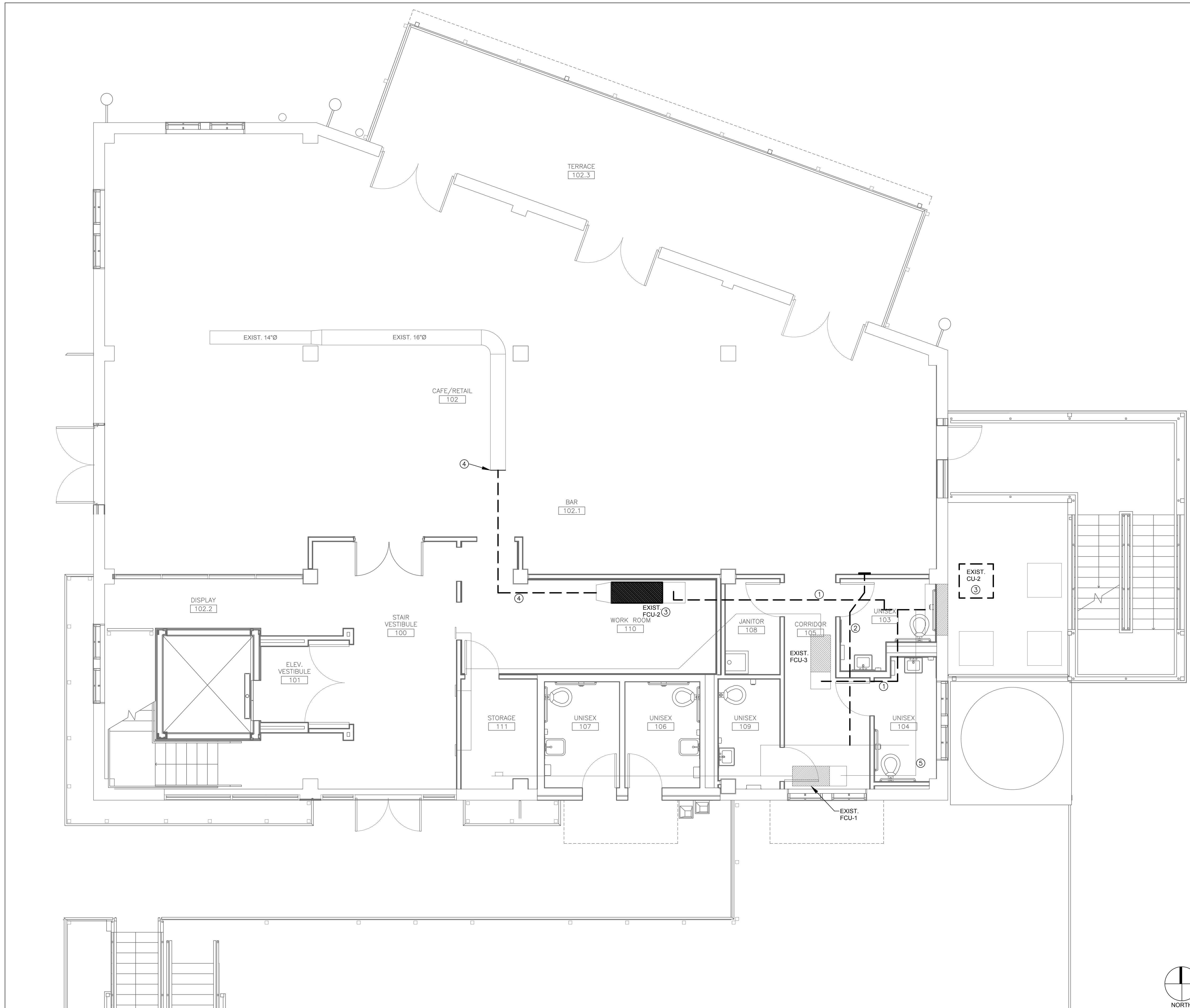

GENERAL NOTES

GENERAL NOTES

KEY NOTES

1. REMOVE EXISTING OUTSIDE AIR DUCT, REMOVE EXISTING SUPPLY AIR DUCTWORK AND ASSOCIATED SIDEWALL GRILLE.
2. REMOVE EXISTING FAN COIL UNIT AND ASSOCIATED CONDENSING UNIT. REMOVE ASSOCIATED REFRIGERANT PIPING. OWNER SHALL RETAIN SALVAGE RIGHTS TO DEMOLISHED EQUIPMENT. CONDENSATE PIPING IS EXISTING TO BE REUSED.
3. REMOVE EXISTING SUPPLY AIR DUCTWORK FROM FAN COIL UNIT CONNECTION TO THIS POINT AS INDICATED.
4. EXISTING OUTSIDE AIR DUCTWORK TO REMAIN.



BRAVE / ARCHITECTURE

4617 Montrose Blvd., Suite C.230
Houston, Texas 77006
Voice: 713.524.5858
Fax: 713.524.5868
studio@bravearchitecture.com
Contact: Silvana Micolich
smicolich@bravearchitecture.com



Consultants:

MEP:

Collaborative Engineering Group
8904 Fairbanks N. Houston Suite 201
Houston, TX 77064
T: 281.598.1170
F: 281.598.1130

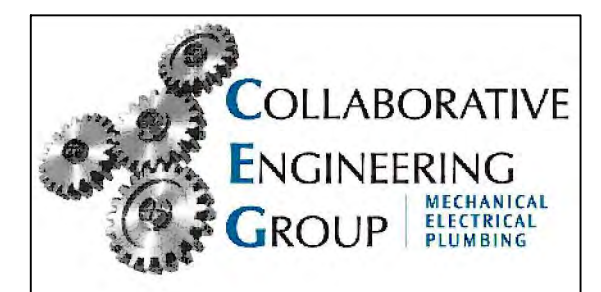

8904 Fairbanks N. Houston, Suite 201
Houston, Texas 77064
281.598.1170
www.collaborative-engr.com
Firm No. F12678

SUNSET COFFEE

1019 Commerce St.
Houston, TX 77002

Ownership of Instruments of Service:
All reports, plans, specifications, computer files, field data, notes & other documents and instruments prepared by BRAVE / ARCHITECTURE as instruments of service shall remain the property of BRAVE / ARCHITECTURE. BRAVE / ARCHITECTURE shall retain all common law, statutory and other reserved rights, including the copyright thereto.

ISSUE FOR PERMIT 02.25.2016

B/A Project No.: 15137
Drawn By: XX
Checked By: XX
Date:
Scale: AS NOTED

MECHANICAL DEMOLITION FLOOR PLAN

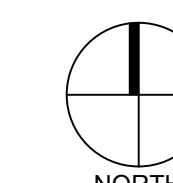

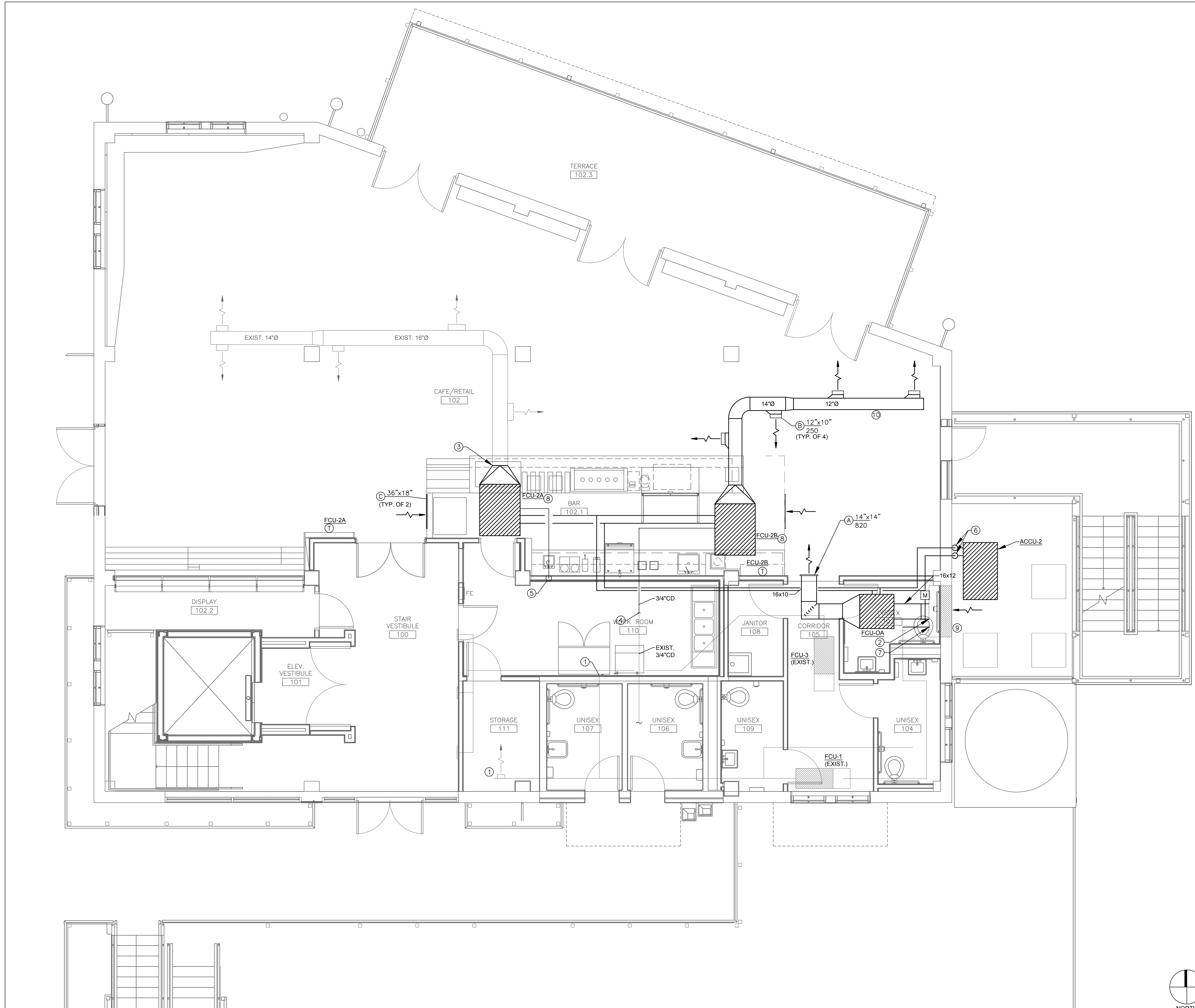

GENERAL NOTES

KEY NOTES

1. BALANCE EXISTING SUPPLY AIR GRILLE TO 175 CFM. BALANCE EXISTING FCU-1 TO 845 CFM.
2. CONNECT NEW 16"x10" OUTSIDE AIR DUCT TO EXISTING OUTSIDE AIR PLENUM.
3. CONNECT NEW FAN COIL UNIT TO EXISTING 16"Ø SUPPLY DUCT.
4. CONNECT NEW 3/4" CONDENSATE PIPE TO EXISTING 3/4" CONDENSATE.
5. ROUTE 3/4" CONDENSATE DOWN WALL TO TAIL PIECE OF DRAIN PIPE.
6. ROUTE REFRIGERANT PIPING FROM CONDENSING UNIT UP TO ABOVE THE CEILING THEN TURN AND ROUTE TO FAN COIL UNITS.
7. CONNECT EXISTING 6"Ø OUTSIDE AIR DUCT SERVING FCU-1 TO EXISTING OUTSIDE AIR PLENUM WITH BALANCING DAMPER.
8. INSTALL FAN COIL UNIT AS HIGH AS POSSIBLE TIGHT TO STRUCTURE.
9. LOUVER IS EXISTING TO REMAIN.
10. INTERNALLY LINED DUCTWORK. REFER TO ARCHITECT FOR FINISH OF DUCTWORK.

B/A
BRAVE / ARCHITECTURE
 4617 Montrose Blvd., Suite C.230
 Houston, Texas 77006
 Voice: 713.524.5858
 Fax: 713.524.5868
 studio@bravearchitecture.com
 Contact: Silvana Micolich
 smicolich@bravearchitecture.com



Consultants:
 MEP:
 Collaborative Engineering Group
 8904 Fairbanks N. Houston Suite 201
 Houston, TX 77064
 T: 281.598.1170
 F: 281.598.1130

COLLABORATIVE ENGINEERING GROUP
 MECHANICAL ELECTRICAL PLUMBING
 8904 Fairbanks N. Houston, Suite 201
 Houston, Texas 77064
 281.598.1170
 www.collaborative-engr.com
 Firm No. F12678

SUNSET COFFEE

1019 Commerce St.
 Houston, TX 77002

Ownership of Instruments of Service:
 All reports, plans, specifications, computer files, field data, notes & other documents and instruments prepared by BRAVE / ARCHITECTURE as instruments of service shall remain the property of BRAVE / ARCHITECTURE. BRAVE / ARCHITECTURE shall retain all common law, statutory and other reserved rights, including the copyright thereto.

ISSUE FOR PERMIT 02.25.2016

B/A Project No.: 15137
 Drawn By: XX
 Checked By: XX
 Date:
 Scale: AS NOTED

MECHANICAL FLOOR PLAN

MECHANICAL FLOOR PLAN

1/4" = 1'-0" 1

P:\Projects\01012016\0202-000 Sunset Coffee Shop\M1.01.dwg, 2/25/2016 11:39:50 AM, Arch, ARCHT full Med D (6.00 x 26.00 Inches), 1:1

FAN COIL UNIT SCHEDULE

EQUIPMENT NO.	SERVICE	SUPPLY CFM	FAN MOTOR HP	FAN MOTOR ESP	ELECTRICAL V/ø/Hz	COOLING COIL MBH (TH/SH)	COOLING COIL EAT (DB/WB)	COOLING COIL NO. OF ROWS	HEATING CAPACITY (MBH)	MANUFACTURER AND MODEL	NOTES
FCU-2A	CAFE	1000	1/2	0.5	208/1/60	30.9/23.4	76.1/63.5	1	-	DAIKIN FXMQ36PBVJU	1-3,6
FCU-2B	CAFE	1000	1/2	0.5	208/1/60	30.9/23.4	76.1/63.5	1	-	DAIKIN FXMQ36PBVJU	1-3,6
FCU-0A	CAFE	950	1/2	0.5	208/1/60	72	105/97.02	2	38.6	DAIKIN FXMQ72MFVJU	1-6

NOTES:

- PROVIDE MERV 8 FILTERS WITH FILTER HOUSING PROVIDED BY MECHANICAL CONTRACTOR.
- PROVIDE SINGLE POINT ELECTRICAL CONNECTION.
- PROVIDE MODEL SPECIFIED OR APPROVED EQUAL.
- PROVIDE UNIT WITH WRAP AROUND HEAT PIPE.
- INTERLOCK FAN COIL UNIT WITH TIMESWITCH. UNIT SHALL ENERGIZE "ON" DURING OCCUPIED HOURS AND DE-ENERGIZE "OFF" DURING UNOCCUPIED HOURS.
- PROVIDE FLOAT SWITCH IN CONDENSATE DRAIN PAN TO DE-ENERGIZE UNIT TO PREVENT OVERFLOW.

AIR COOLED CONDENSING UNIT SCHEDULE

EQUIPMENT NO.	SERVICE	COOLING CAPACITY (TONS)	MIN EER (ACTUAL/ARI)	AMBIENT TEMP (°F)	ELECTRICAL V/ø/Hz	FANS	REFRIGERANT	MANUFACTURER AND MODEL	NOTES
ACCU-2	FCU-2A/2B	12	11.5	105	460/3/60	2	R410A	DAIKIN RXYQ144TYDN	1-3

NOTES:

- PROVIDE THERMAL EXPANSION VALVE.
- TEN YEAR WARRANTY.
- PROVIDE MODEL SPECIFIED OR APPROVED EQUAL.

GRILLE - REGISTER - DIFFUSER SCHEDULE

NO.	SIZE	TYPE	MANUFACTURER AND MODEL	FINISH	DESCRIPTION	NOTES
A	AS SHOWN	GRILLE	TITUS 301FL	SEE NOTE 1	SINGLE DEFLECTION GRILLE, 3/4" BLADE SPACING, ALUMINUM CONSTRUCTION, WALL MOUNTING, BLADES PARALLEL IN LONG DIMENSION	1
B	AS SHOWN	GRILLE	TITUS 301FL	SEE NOTE 1	SINGLE DEFLECTION GRILLE, 3/4" BLADE SPACING, ALUMINUM CONSTRUCTION, DUCT MOUNTING, BLADES PARALLEL IN LONG DIMENSION	1
C	AS SHOWN	GRILLE	TITUS 355FL	SEE NOTE 1	3/4" BLADE SPACING, ALUMINUM CONSTRUCTION, 35 DEG. DEFLECTION, WALL MOUNTING, BLADES PARALLEL IN LONG DIMENSION	1

NOTES:

- GRILLE COLOR TO MATCH SURROUNDING WALL OR MATCH DUCTWORK WHEN DUCTWORK/GRILLE ARE EXPOSED.

OUTSIDE AIR CALCULATION

2012 UMC WITH CITY OF HOUSTON AMENDMENTS (TABLE 402.1)

ROOM	ZONE AREA	OUTDOOR AIR RATE CFM/SQ. FT.	CFM REQUIRED	COMMENTS
FCU-2A/2B				
CAFE/RETAIL	2221	0.18	400	
	7.5 CFM PER PERSON	60 PEOPLE	450	
		0.05		
		0.05		
TOTAL O.A. REQUIRED			850	950 CFM O.A. PROVIDED

NOTE:

OUTDOOR AIR REQUIREMENT FOR RESTROOMS PROVIDED BY TRANSFER AIR (TABLE 4-1, FOOTNOTE 4)

DUCT & PIPING MATERIAL & INSULATION SCHEDULE

SYSTEM	DUCT/PIPING MATERIAL	INSULATION MATERIAL
SUPPLY & RETURN DUCT	GALVANIZED SHEET METAL LINER	JOHNS MANVILLE PERMACOTE LINACOUSTIC OR EQUAL, 1-1/2" THICK, 1-1/2 LB/CU FT., NFPA 25/50 FLAME SPREAD AND SMOKE DEVELOPED RATING. MINIMUM R-6 INSIDE AND R-8 OUTSIDE BUILDING ENVELOPE.
SUPPLY, RETURN & OUTSIDE AIR DUCT	GALVANIZED SHEET METAL DUCT WRAP	2" THICK, 1-1/2 LB/CU FT DENSITY FIBERGLASS FOIL-BACK, FLAME SPREAD RATING 25 OR LESS, SMOKE DEVELOPED RATING 50 OR LESS. MINIMUM R-6 INSIDE AND R-8 OUTSIDE BUILDING ENVELOPE.
REFRIGERANT PIPING	TYPE "L" HARD DRAWN COPPER	ARMAFLEX 1" THICKNESS MINIMUM FOR LIQUID LINE
CONDENSATE PIPING	TYPE "L" HARD DRAWN COPPER	ARMAFLEX 200 (25/50 RATED), 3/4" THICKNESS MINIMUM, THICKER IF REQUIRED TO PREVENT CONDENSATION AT 85°F AND 70% RELATIVE HUMIDITY

NOTES:

- FIRST 20 FT OF SUPPLY AND RETURN AIR DUCTWORK DOWNSTREAM OF AIR HANDLING EQUIPMENT SHALL BE LINED. REMAINING DUCTWORK SHALL BE WRAPPED UNLESS OTHERWISE NOTED.
- DUCT AND PLENUMS SHALL BE SEALED IN ACCORDANCE WITH THE MECHANICAL CODE AND SMACNA METHOD A.

DUCT CONSTRUCTION MINIMUM SHEET METAL THICKNESS

RECTANGULAR DUCTS			
MAXIMUM SIZE (INCHES)	STEEL (MINIMUM THICKNESS, NORMAL)	ALUMINUM (MINIMUM THICKNESS, NORMAL)	
THROUGH 12	0.022 INCH (26 GAGE, GALV.)	0.020 INCH (NO. 24 B&S GAGE)	
13 THROUGH 30	0.028 INCH (24 GAGE, GALV.)	0.025 INCH (NO. 22 B&S GAGE)	
31 THROUGH 54	0.034 INCH (22 GAGE, GALV.)	0.032 INCH (NO. 20 B&S GAGE)	
ROUND DUCTS			
MAXIMUM SIZE (INCHES)	SPIRAL SEAM DUCT	LONGITUDINAL SEAM DUCT	FITTINGS
	STEEL (MINIMUM THICKNESS, NORMAL)	STEEL (MINIMUM THICKNESS, NORMAL)	STEEL (MINIMUM THICKNESS, NORMAL)
THROUGH 12	0.019 INCH (28 GAGE, GALV.)	0.022 INCH (26 GAGE, GALV.)	0.022 INCH (26 GAGE, GALV.)
13 THROUGH 18	0.022 INCH (26 GAGE, GALV.)	0.028 INCH (24 GAGE, GALV.)	0.028 INCH (24 GAGE, GALV.)

ENERGY CODE COMPLIANCE REQUIREMENTS

- DRAWINGS:** CONSTRUCTION DOCUMENTS SHALL REQUIRE THAT WITHIN 90 DAYS AFTER THE DATE OF SYSTEM ACCEPTANCE RECORD DRAWINGS OF THE ACTUAL INSTALLATION BE PROVIDED TO THE BUILDING OWNER OR THE DESIGNATED REPRESENTATIVE OF THE BUILDING OWNER. RECORD DRAWINGS SHALL INCLUDE AS A MINIMUM THE LOCATION AND PERFORMANCE DATA ON EACH PIECE OF EQUIPMENT, GENERAL CONFIGURATION OF DUCT AND PIPE DISTRIBUTION SYSTEM INCLUDING SIZES, AND THE TERMINAL AIR OR WATER DESIGN FLOW RATES.
- MANUALS:** CONSTRUCTION DOCUMENTS SHALL REQUIRE THAT AN OPERATING MANUAL AND A MAINTENANCE MANUAL BE PROVIDED TO THE BUILDING OWNER OR THE DESIGNATED REPRESENTATIVE OF THE BUILDING OWNER WITHIN 90 DAYS AFTER THE DATE OF SYSTEM ACCEPTANCE. THESE MANUALS SHALL BE IN ACCORDANCE WITH INDUSTRY-ACCEPTED STANDARDS (SEE APPENDIX E) AND SHALL INCLUDE, AT A MINIMUM THE FOLLOWING:
 - SUBMITTAL DATA STATING EQUIPMENT SIZE AND SELECTED OPTIONS FOR EACH PIECE OF EQUIPMENT REQUIRING MAINTENANCE.
 - OPERATION MANUALS AND MAINTENANCE MANUALS FOR EACH PIECE OF EQUIPMENT REQUIRING MAINTENANCE, EXCEPT EQUIPMENT NOT FURNISHED AS PART OF THE PROJECT. REQUIRED ROUTINE MAINTENANCE ACTIONS SHALL BE CLEARLY IDENTIFIED.
 - NAMES AND ADDRESSES OF AT LEAST ONE SERVICE AGENCY.
 - HVAC CONTROLS SYSTEM MAINTENANCE AND CALIBRATION INFORMATION, INCLUDING WIRING DIAGRAMS, SCHEMATICS, AND CONTROL SEQUENCE DESCRIPTIONS. DESIRED OR FIELD-DETERMINED SET-POINTS SHALL BE PERMANENTLY RECORDED ON CONTROL DRAWINGS AT CONTROL DEVICES OR FOR DIGITAL CONTROL SYSTEMS IN PROGRAMMING COMMENTS.
 - A COMPLETE NARRATIVE OF HOW EACH SYSTEM IS INTENDED TO OPERATE, INCLUDING SUGGESTED SET-POINTS.



BRAVE / ARCHITECTURE

4617 Montrose Blvd., Suite C.230
Houston, Texas 77006
Voice: 713.524.5858
Fax: 713.524.5868
studio@bravearchitecture.com
Contact: Silvana Micolich
smicolich@bravearchitecture.com



Consultants:

MEP:

Collaborative Engineering Group
8904 Fairbanks N. Houston Suite 201
Houston, TX 77064
T: 281.598.1170
F: 281.598.1130

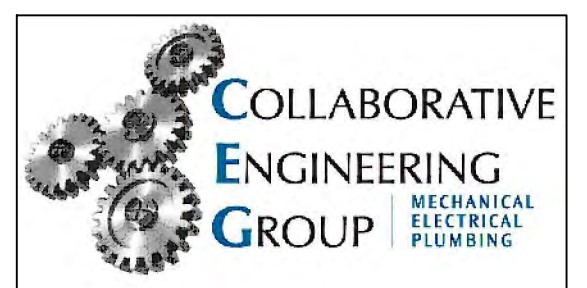

8904 Fairbanks N. Houston, Suite 201
Houston, Texas 77064
281.598.1170
www.collaborative-engr.com
Firm No. F12678

SUNSET COFFEE

1019 Commerce St.
Houston, TX 77002

Ownership of Instruments of Service:
All reports, plans, specifications, computer files, field data, notes & other documents and instruments prepared by BRAVE / ARCHITECTURE as instruments of service shall remain the property of BRAVE / ARCHITECTURE. BRAVE / ARCHITECTURE shall retain all common law, statutory and other reserved rights, including the copyright thereto.

ISSUE:
ISSUE FOR PERMIT 02.25.2016

B/A Project No.: 15137
Drawn By: XX
Checked By: XX
Date:
Scale: AS NOTED

MECHANICAL SCHEDULES

M4.00

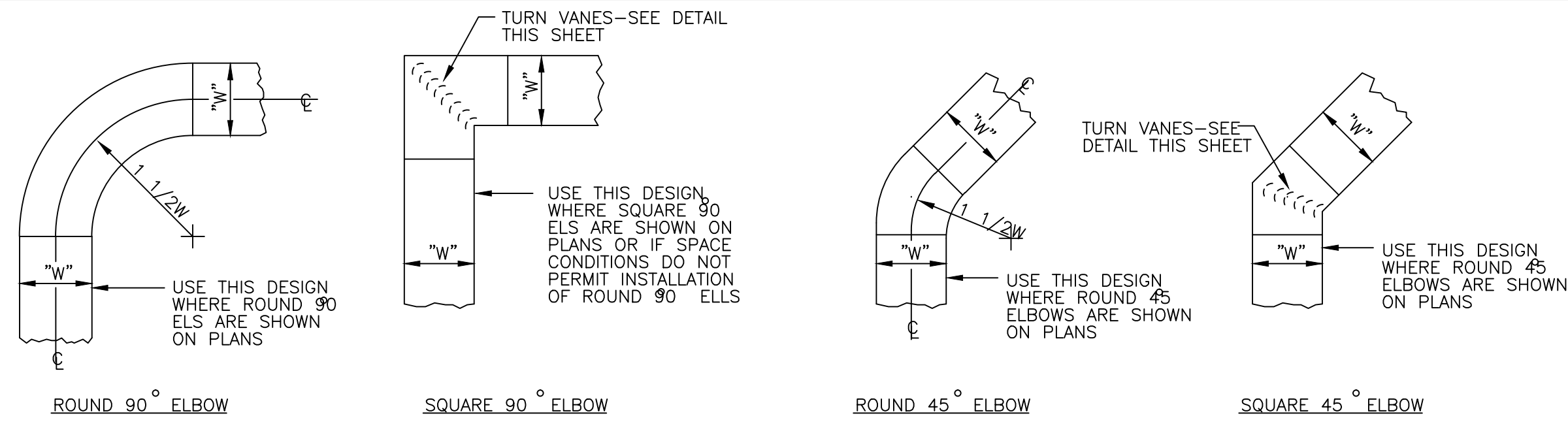

CONSTRUCTION OF 90° ELBOWS

CONSTRUCTION OF 45° ELBOWS

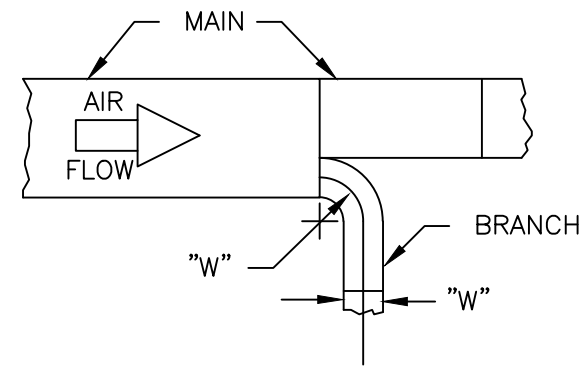

ROUND BRANCH TAKEOFF

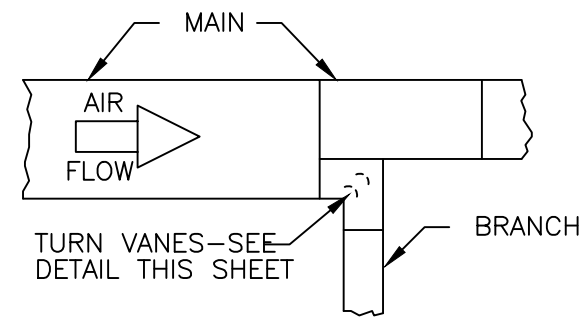

SQUARE BRANCH TAKEOFF

CONSTRUCTION OF BRANCH TAKEOFFS FROM MAIN

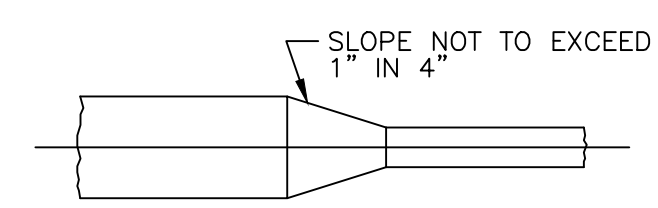

TYPICAL RECTANGULAR TRANSITION

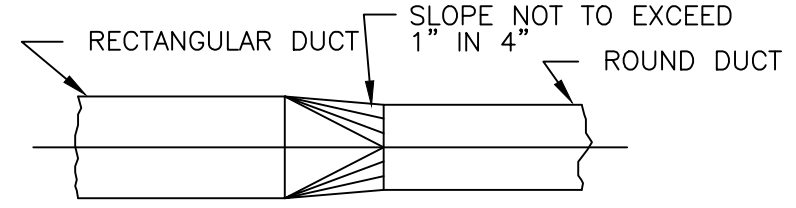

TYPICAL RECTANGULAR TO ROUND TRANSITION

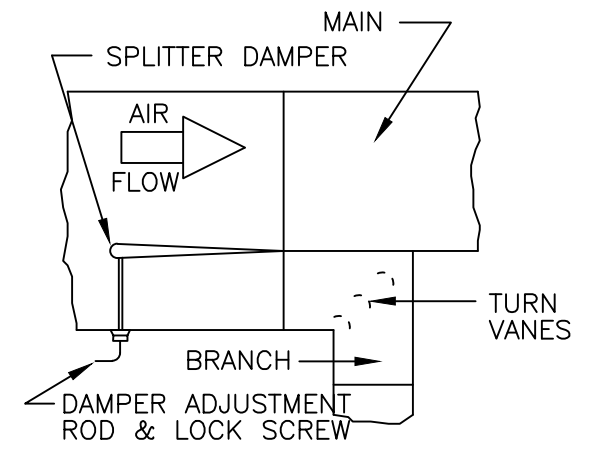

TYPICAL SPLITTER DAMPER

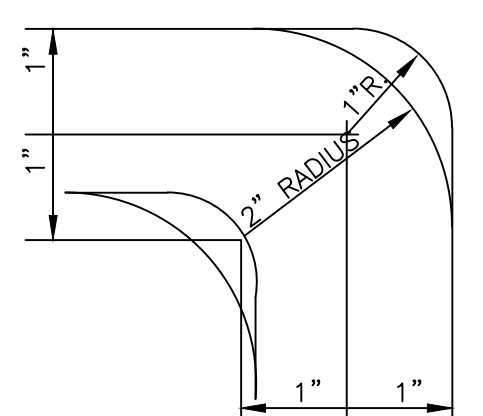

DETAIL OF TURN VANES

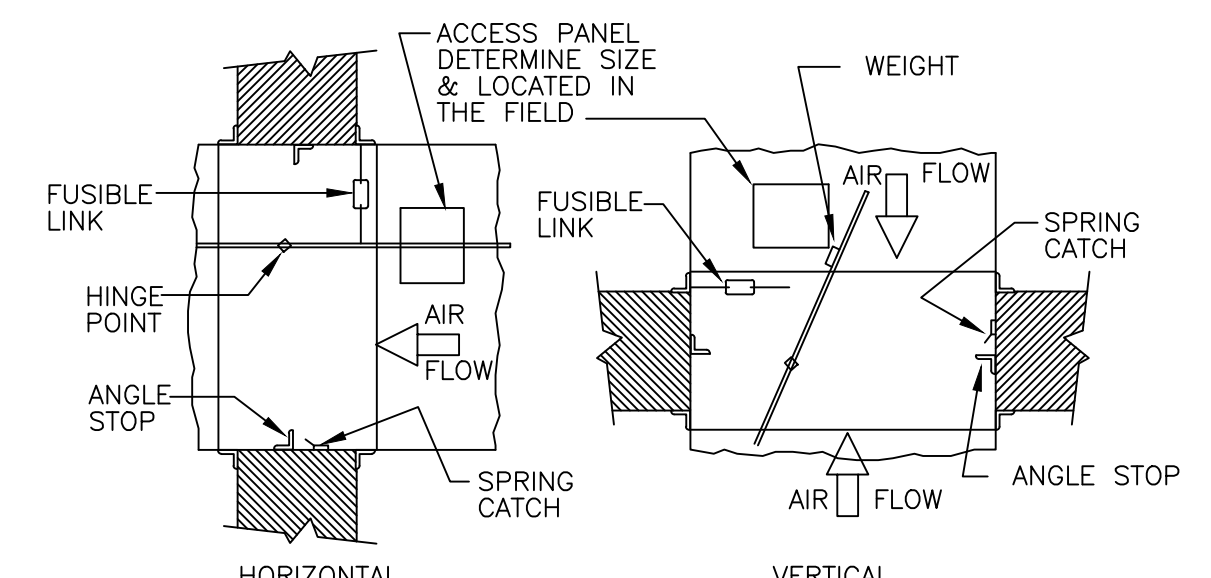

DETAILS OF THE LOW VELOCITY DUCT LAYOUT

NOT TO SCALE

- INSTALLATION NOTES**
1. ALL DUCTS SHALL BE CONSTRUCTED AND ERECTED IN A NEAT AND WORKMANLIKE MANNER.
 2. DUCTS SHALL BE CONSTRUCTED OF THE WEIGHTS, GAGES AND MATERIAL SHOWN IN THE SCHEDULE ON THESE DRAWINGS.
 3. THE DIMENSION SHOWN FOR ALL DUCTS SHOWN IN PLAN GIVE THE WIDTH FIRST AND THEN THE HEIGHT.
 4. DUCT RISERS SHOULD BE SUPPORTED BY ANGLES AT EVERY FLOOR.
 5. AIR TURN SHALL BE INSTALLED IN ALL ABRUPT ELBOWS TO PREVENT TURBULENCE.
 6. DUCTS SHALL BE SECURELY ATTACHED TO THE BUILDING CONSTRUCTION IN AN APPROVED MANNER.
 7. DIVERGING TRANSITION PIECES SHALL BE MADE AS GRADUAL AS POSSIBLE.
 8. INSTALL FIRE DAMPERS IN ACCORDANCE WITH UL 555.
 9. ACCESS PANELS SHOULD BE PLACED BEFORE AND/OR AFTER EQUIPMENT INSTALLED IN THE DUCT.
 10. DUCT AREA SHOULD NOT BE DECREASED MORE THAN 10 PERCENT WHEN OBSTRUCTIONS CANNOT BE AVOIDED, AND THEN A STREAMLINED FITTING SHOULD BE USED.
 11. FLEXIBLE FABRIC CONNECTIONS (OR EQUAL) SHOULD BE USED ON BOTH INLETS AND OUTLETS OF ALL FANS AND AIR HANDLING UNITS.
 12. JOINTS AND SEAMS OF SUPPLY DUCTS SHALL BE FASTENED SECURELY AND MADE AIR TIGHT.

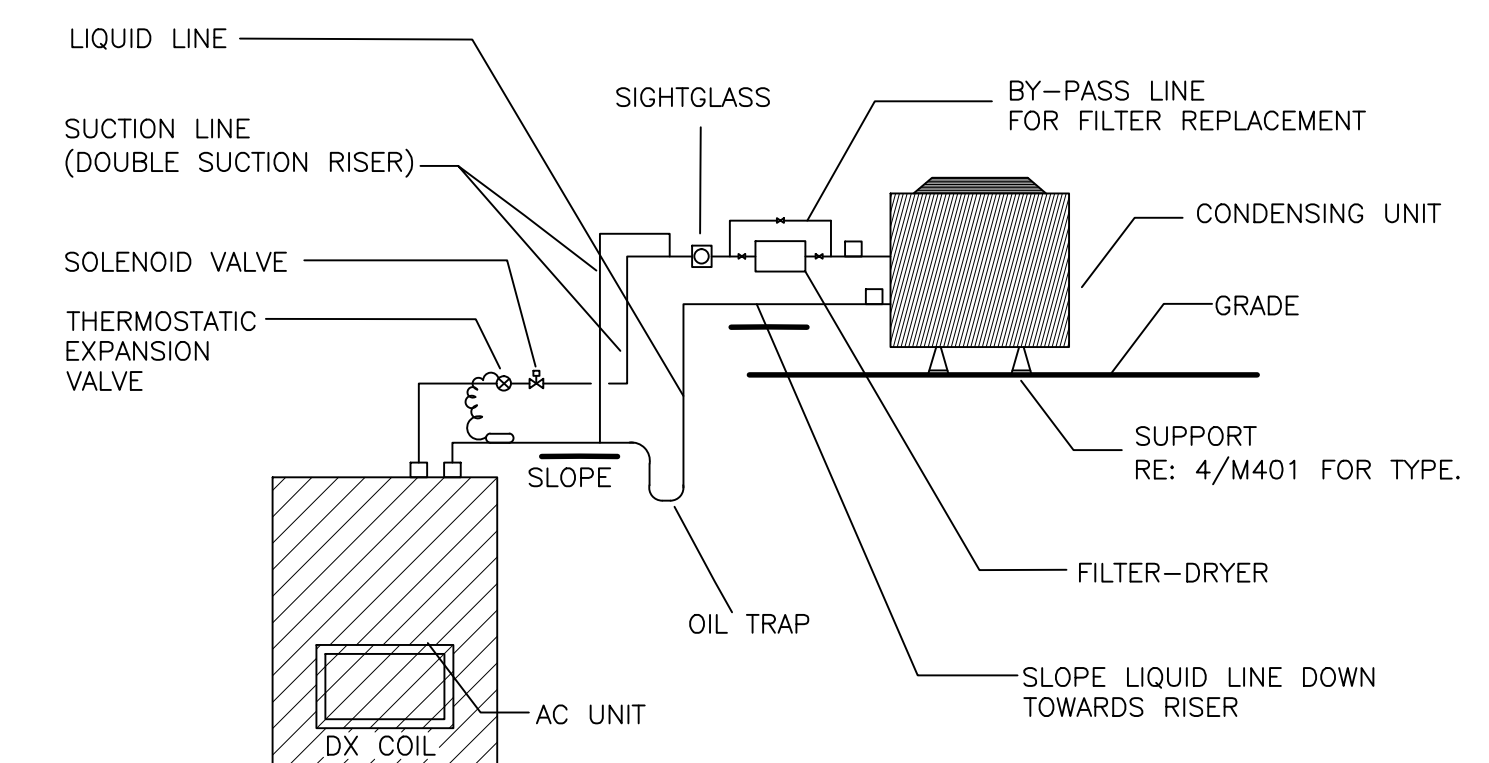

REFRIGERANT PIPING SYSTEM

NOT TO SCALE

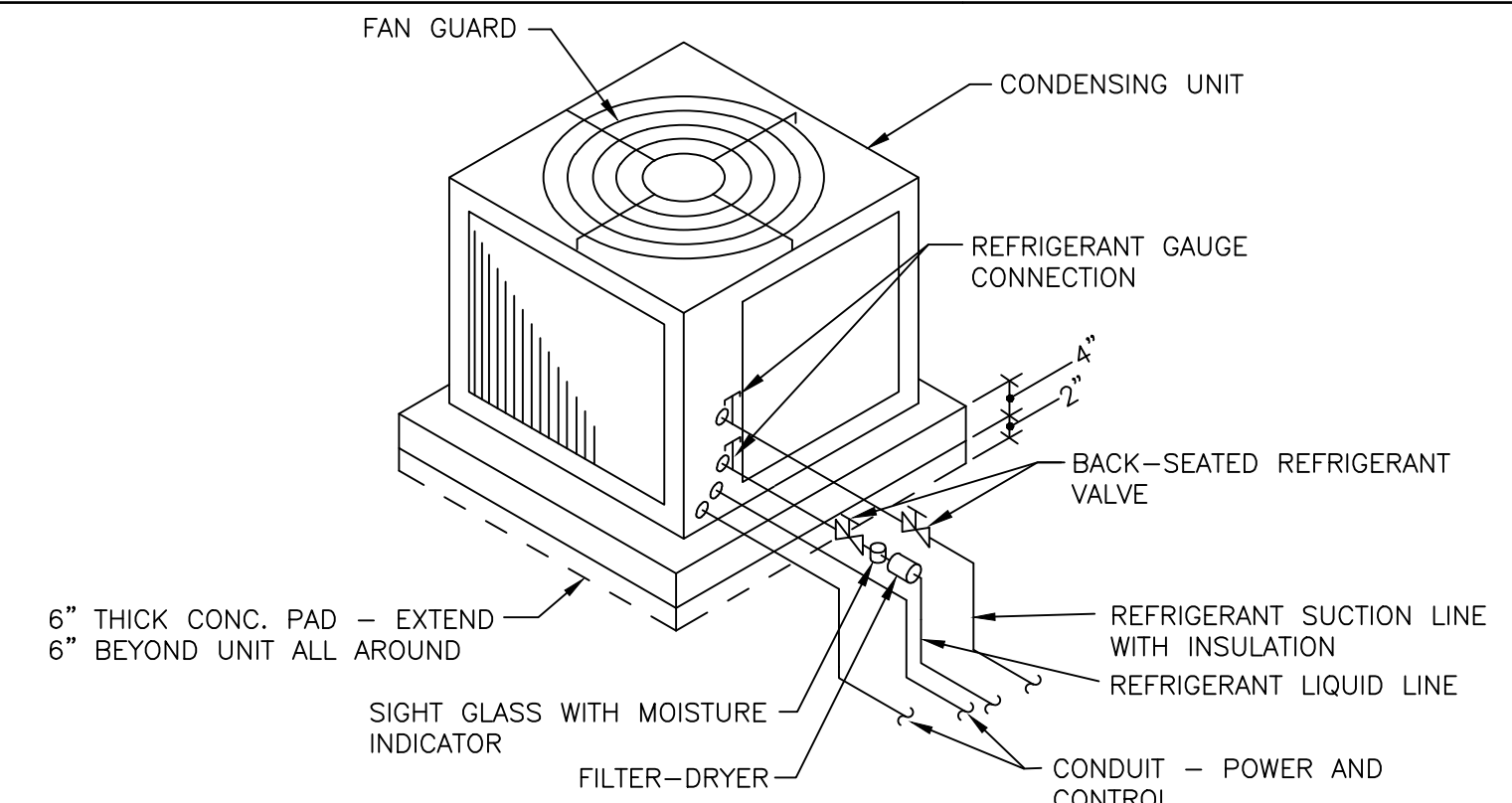

AIR-COOLED CONDENSING UNIT - SLAB MOUNTED AT GRADE

NOT TO SCALE



BRAVE / ARCHITECTURE

4617 Montrose Blvd., Suite C.230
Houston, Texas 77006
Voice: 713.524.5858
Fax: 713.524.5868
studio@bravearchitecture.com
Contact: Silvana Micolich
smicolich@bravearchitecture.com

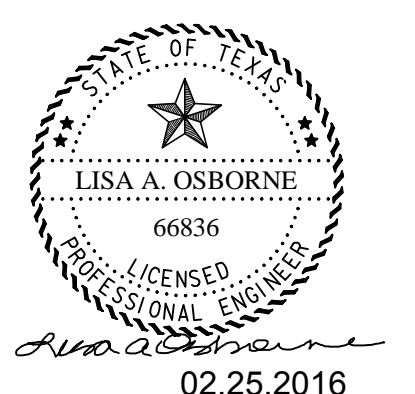

02.25.2016

Consultants:

MEP:

Collaborative Engineering Group
8904 Fairbanks N. Houston Suite 201
Houston, TX 77064
T: 281.598.1170
F: 281.598.1130



8904 Fairbanks N. Houston, Suite 201
Houston, Texas 77064
281.598.1170
www.collaborative-engr.com
Firm No. F12678

SUNSET COFFEE

1019 Commerce St.
Houston, TX 77002

Ownership of Instruments of Service:
All reports, plans, specifications, computer files, field data, notes & other documents and instruments prepared by BRAVE / ARCHITECTURE as instruments of service shall remain the property of BRAVE / ARCHITECTURE. BRAVE / ARCHITECTURE shall retain all common law, statutory and other reserved rights, including the copyright thereto.

ISSUE FOR PERMIT 02.25.2016

B/A Project No.: 15137
Drawn By: XX
Checked By: XX
Date:
Scale: AS NOTED

MECHANICAL DETAILS

M5.00

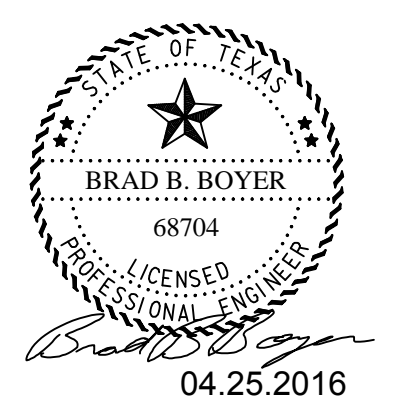

Consultants:

MEP:

Collaborative Engineering Group
8904 Fairbanks N. Houston Suite 201
Houston, TX 77064
T: 281.598.1170
F: 281.598.1130

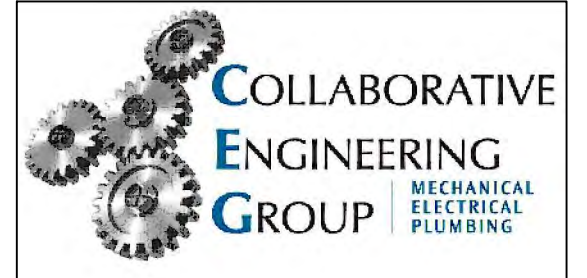

8904 Fairbanks N. Houston, Suite 201
Houston, Texas 77064
281.598.1170
www.collaborative-engr.com
Firm No. F12678

SUNSET COFFEE

1019 Commerce St.
Houston, TX 77002

Ownership of Instruments of Service:
All reports, plans, specifications, computer files, field data, notes & other documents and instruments prepared by BRAVE / ARCHITECTURE as instruments of service shall remain the property of BRAVE / ARCHITECTURE. BRAVE / ARCHITECTURE shall retain all common law, statutory and other reserved rights, including the copyright thereto.

ISSUE:
ISSUE FOR PERMIT 02.25.2016
PERMIT RESPONSES 04.25.2016

B/A Project No.: 15137
Drawn By: TLK
Checked By: BBB
Date:
Scale: AS NOTED

ELECTRICAL SYMBOLS & ABBREVIATIONS

ELECTRICAL DRAWING LIST	
Sheet Number	Sheet Name
E0.00	ELECTRICAL SYMBOLS AND ABBREVIATIONS
E0.01	ELECTRICAL SPECIFICATIONS
E1.01	ELECTRICAL LIGHTING FLOOR PLAN
E1.11	ELECTRICAL LIGHTING DEMOLITION PLAN
E2.01	ELECTRICAL POWER FLOOR PLAN
E2.11	ELECTRICAL POWER DEMOLITION PLAN
E6.00	ELECTRICAL ONE LINE, LOAD ANALYSIS & FAULT ANALYSIS
E8.00	ELECTRICAL SCHEDULES
E8.01	ELECTRICAL SCHEDULES
E9.00	ELECTRICAL DETAILS

ELECTRICAL ABBREVIATIONS			
ABBR.	DEFINITION	ABB	DEFINITION
A	AMPERE	KW	KILOWATT
ABC	ABOVE COUNTER	LC	LOCKABLE COVER
AC	ALTERNATING CURRENT	LTG	LIGHTING
ADO	AUTOMATIC DOOR OPENER	MAX	MAXIMUM
AF	AMPERE FUSE	MCB	MAIN CIRCUIT BREAKER
AFF	ABOVE FINISHED FLOOR	MCC	MOTOR CONTROL CENTER
AFG	ABOVE FINISHED GROUND	KCMIL	KILO-CIRCULAR MILS
AHU	AIR HANDLING UNIT	MECH	MECHANICAL
KAIC	AMPS INTERRUPTING CAPACITY X1000	MFR	MANUFACTURER
AT	AMPERE TRIP	MGAP	MEDICAL GAS ALARM PANEL
ANN	ANNUNCIATOR	MLO	MAIN LUGS ONLY
APRX.	APPROXIMATE	MTD	MOUNTED
ARCH	ARCHITECT	MTG	MOUNTING
ATS	AUTOMATIC TRANSFER SWITCH	NEC	NATIONAL ELECTRICAL CODE
AWG	AMERICAN WIRE GAUGE	NTS	NOT TO SCALE
BLDG	BUILDING	PNL	PANEL
BSMT	BASEMENT	PH	PHASE
C	CENTER	P	POLE
CAB	CABINET	PFB	PROVISIONS FOR BREAKING
CB	CIRCUIT BREAKER	PA	PUBLIC ADDRESS
CKT	CIRCUIT	POE	POWER OVER ETHERNET
CLG	CEILING	RECP	RECEPTACLE
CL	CENTER LINE	REFRIG	REFRIGERATOR
CU	COPPER	REQD	REQUIRED
DN	DOWN	SN	SOLID NEUTRAL
DWG	DRAWING	SPKR	SPEAKER
EA	EACH	SPEC	SPECIFICATION
EF	EXHAUST FAN	SWBD	SWITCHBOARD
ELEV	ELEVATOR/ELEVATION	SWGR	SWITCHGEAR
EQPT	EQUIPMENT	TC	TIME CLOCK
EXTG	EXISTING	TEL	TELEPHONE
FA	FIRE ALARM	TTB	TELEPHONE TERMINAL BOARD
FACP	FIRE ALARM CONTROL PANEL	TV	TELEVISION
FCU	FAN COIL UNIT	TVSS	TRANSIENT VOLT. SURGE SUPPRESSOR
FLA	FULL LOAD AMPACITY	TYP	TYPICAL
GFI	GROUND FAULT INTERRUPTER	UC	UNDER COUNTER
GND	GROUND	UH	UNIT HEATER
HTR	HEATER	V	VOLT
HP	HORSEPOWER	VA	VOLTAMPERE
HW	HOT WATER	W	WATT
IG	ISOLATED GROUND	WH	WATER HEATER
INCAND	INCANDESCENT	W/	WITH
JB	JUNCTION BOX	W/O	WITHOUT
KV	KILOVOLT	XFMR	TRANSFORMER
KVA	KILOVOLT-AMPERE	XFR	TRANSFER

- GENERAL ELECTRICAL CONSTRUCTION NOTES:**
- DRAWINGS ARE SCHEMATIC IN NATURE AND MAY NOT BE DRAWN EXACTLY TO SCALE. CONTRACTOR IS RESPONSIBLE FOR COORDINATING EXACT ROUTING OF ALL SERVICES WITH EXISTING CONDITIONS AND WITH ALL OTHER TRADES.
 - PROVIDE TYPED DIRECTORY CARDS UNDER PLASTIC DOORS OF BRANCH CIRCUIT PANELBOARDS. DIRECTORIES SHALL INDICATE DEVICES BEING SERVED INCLUDING SPACE NUMBERS IN WHICH DEVICES OR FIXTURES ARE LOCATED. SPACE NAMES AND NUMBERS SHALL MATCH GRAPHICS INSTALLED IF DIFFERENT FROM THE SPACE NAMES AND NUMBERS ON THE DRAWINGS.
 - ALL RECEPTACLES SHALL BE 20A. ALL SWITCHES SHALL BE 20A QUIET TYPE.
 - REFER TO THE ELECTRICAL SPECIFICATIONS FOR ADDITIONAL DESIGN STANDARDS. THE ELECTRICAL SPECIFICATIONS ARE A BINDING PART OF THE CONSTRUCTIONS DOCUMENTS.
 - PROVIDE CODE COMPLIANT PENETRATIONS FOR ALL CONDUITS ENTERING/EXITING FIRE RATED WALLS. REFER TO ARCHITECTURAL DRAWINGS FOR LOCATIONS OF ALL FIRE RATED WALLS.
 - REFER TO MECHANICAL PLANS FOR EQUIPMENT REQUIRING ELECTRICAL CONNECTIONS.
 - REFER TO ARCHITECTURAL PLANS FOR RATED WALLS AND UL LISTED FIRE RATED DETAILS.
 - ELECTRICAL WORK SHALL BE IN ACCORDANCE WITH TEXAS DEPARTMENT OF LICENSING AND REGULATION (TDLR) AND LOCAL CODES.
 - FOR ALL WORK INSIDE THE CITY OF HOUSTON LIMITS, PROVIDE FAULT CURRENT LABELING AS SPECIFIED IN SECTION 804.1.1 OF THE CITY OF HOUSTON ELECTRICAL CODE. PROVIDE A 2"x3" LABEL WITH BLUE LETTERING ON A CONTRASTING BACKGROUND. LABEL IS TO SHOW AVAILABLE FAULT CURRENT AT TIME OF INSTALLATION AND TO INCLUDE THE DATE OF THE CALCULATION.

RECEPTACLES		
SYMBOL	DESCRIPTION	MOUNTING HEIGHT
	120V. DUPLEX RECEPTACLE - (REFER TO RECEPTACLE ABBREVIATIONS FOR EXCEPTIONS)	1'-6" AFF TO CL. U.N.O.
	120V. QUADPLEX RECEPTACLE - (REFER TO RECEPTACLE ABBREVIATIONS FOR EXCEPTIONS)	1'-6" AFF TO CL. U.N.O.
	120V. GFI RECEPTACLE	1'-6" AFF TO CL. U.N.O.
	120V. GFI ABOVE COUNTER RECEPTACLE	REFER TO ARCHITECTURAL
	120V. DUPLEX RECEPTACLE W/ INTEGRATED 5.0V, 2.0A OUTLETS	1'-6" AFF TO CL. U.N.O.
	120. DUPLEX HALF SWITCHED RECEPTACLE	1'-6" AFF TO CL. U.N.O.
	120V. DUPLEX FLOOR RECEPTACLE	1'-6" AFF TO CL. U.N.O.
	SINGLE RECEPTACLE (TYPE AS NOTED ON PLANS) REFER TO RECEPTACLE ABBREVIATIONS FOR EXCEPTIONS)	1'-6" AFF TO CL. U.N.O.
	120V. DUPLEX RECEPTACLE - CRITICAL (REFER TO RECEPTACLE ABBREVIATIONS FOR EXCEPTIONS)	1'-6" AFF TO CL. U.N.O.
	120V. QUADPLEX RECEPTACLE - CRITICAL (REFER TO RECEPTACLE ABBREVIATIONS FOR EXCEPTIONS)	1'-6" AFF TO CL. U.N.O.
	120. GFI RECEPTACLE - CRITICAL	1'-6" AFF TO CL. U.N.O.
	SINGLE RECEPTACLE - CRITICAL - (TYPE AS NOTED ON PLANS) (REFER TO RECEPTACLE ABBREVIATIONS FOR EXCEPTIONS)	1'-6" AFF TO CL. U.N.O.

SWITCHES		
SYMBOL	DESCRIPTION	MOUNTING HEIGHT
	SINGLE POLE SWITCH	3'-10" AFF TO CL. UNLESS NOTED OTHERWISE
	DOUBLE POLE SWITCH - CENTER OFF	3'-10" AFF TO CL. UNLESS NOTED OTHERWISE
	THREE WAY SWITCH	3'-10" AFF TO CL. UNLESS NOTED OTHERWISE
	FOUR WAY SWITCH	3'-10" AFF TO CL. UNLESS NOTED OTHERWISE
	SINGLE POLE SWITCH KEY OPERATED	3'-10" AFF TO CL. UNLESS NOTED OTHERWISE
	DIMMER SWITCH	3'-10" AFF TO CL. UNLESS NOTED OTHERWISE
	VARIABLE INTENSITY CONTROL	3'-10" AFF TO CL. UNLESS NOTED OTHERWISE
	INTERVAL TIMER CONTROL SWITCH	3'-10" AFF TO CL. UNLESS NOTED OTHERWISE
	SINGLE POLE SWITCH WITH PILOT LIGHT	3'-10" AFF TO CL. UNLESS NOTED OTHERWISE
	OCCUPANCY SENSOR SWITCH	3'-10" AFF TO CL. UNLESS NOTED OTHERWISE
	JOG SWITCH	3'-10" AFF TO CL. UNLESS NOTED OTHERWISE
	MOTOR RATED SWITCH	
	PUSH BUTTON SWITCH (MUSHROOM BUTTON)	3'-10" AFF TO CL. UNLESS NOTED OTHERWISE
	ROOM OCCUPANCY SENSOR - 360° FIELD OF VIEW	CEILING

NOTICE

FIRE ALARM SYSTEM IS EXISTING TO REMAIN.

COMMUNICATION		
SYMBOL	DESCRIPTION	MOUNTING HEIGHT
	DATA OUTLET	18" AFF OR MATCH POWER OUTLET
	DATA OUTLET(PHONE AND DATA)	ABC, AS NOTED, OR PER ARCH. ELEVATIONS
	DATA OUTLET(FLOOR - FLUSH OR BELOW FLOOR) SUB - SCRIPT REPRESENTS NUMBER OF OUTLETS IN FACEPLATE)	FLUSH FLOOR OR SURFACE MOUNT BOX
	DATA OUTLET (CEILING - FLUSH OR ABOVE CEILING) (SUB - SCRIPT REPRESENTS NUMBER OF OUTLETS IN FACEPLATE)	FLUSH CEILING OR ABOVE CEILING (ACO)
	WIRELESS CISCOR REPEATER	WALL, CEILING OR ABOVE CEILING
	DIRECTIONAL ANTENNA	WALL, CEILING OR ABOVE CEILING
	OMNI-DIRECTIONAL ANTENNA	WALL, CEILING OR ABOVE CEILING
	WALLPHONE VOICE OUTLET	+54" AFF OR PER ARCH. ELEVATIONS
	TELECOMMUNICATIONS GROUNDING BAR (ELEVATION VIEW)	WALL MOUNTED OR AS VENDOR SPECIFIED
	TELEVISION OUTLET	ABC, AS NOTED, OR PER ARCH. ELEVATIONS
	PHONE VOICE OUTLET	1'6" AFF TO CL. UNLESS OTHERWISE NOTED

RACEWAY		
SYMBOL	DESCRIPTION	MOUNTING HEIGHT
	CONDUIT & BRANCH CIRCUIT WIRING	
	BRANCH CIRCUIT RACEWAY CONCEALED IN OR BELOW FLOOR SLAB OR BELOW GRADE	
	FEEDER RACEWAY CONCEALED IN OR BELOW FLOOR SLAB OR BELOW GRADE	
	RACEWAY TURNING UP AS VIEWED FROM THE LOAD	
	RACEWAY TURNING DOWN AS VIEW FROM THE LOAD	
	RACEWAY VERTICAL RISER WITH HORIZONTAL CONTINUATION AT TWO LEVELS SHOWN	
	CAPPED RACEWAY	
	CIRCUIT CONTINUATION	
	HOMERUN TO PANELBOARD - NUMBER OF ARROWHEADS INDICATED NUMBER OF #12 AWG PHASE CONDUCTORS. FOR MINIMUM CONDUIT REFER TO SPECIFICATION.	
	NOTES:	
	1. #12 AWG NEUTRAL CONDUCTOR, ALTHOUGH NOT INDICATED, SHALL BE INCLUDED IN EACH RACEWAY UNLESS OTHERWISE NOTED.	
	2. #12 AWG GREEN GROUND CONDUCTOR, ALTHOUGH NOT INDICATED, SHALL BE INCLUDED IN EACH RACEWAY UNLESS OTHERWISE NOTED.	
	3. HOMERUNS TO PANELBOARDS SHALL HAVE A MAXIMUM OF THREE(3) PHASE CONDUCTORS (ONE PER PHASE) PLUS NEUTRAL AND GROUND CONDUCTORS IN EACH CONDUIT.	



BRAVE / ARCHITECTURE

4617 Montrose Blvd., Suite C.230
Houston, Texas 77006
Voice: 713.524.5858
Fax: 713.524.5868
studio@bravearchitecture.com
Contact: Silvana Micolich
smicolich@bravearchitecture.com

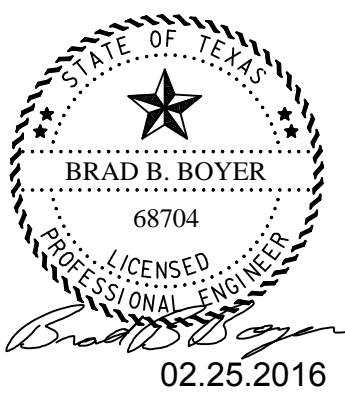

Consultants:

MEP:

Collaborative Engineering Group
8904 Fairbanks N. Houston Suite 201
Houston, TX 77064
T: 281.598.1170
F: 281.598.1130

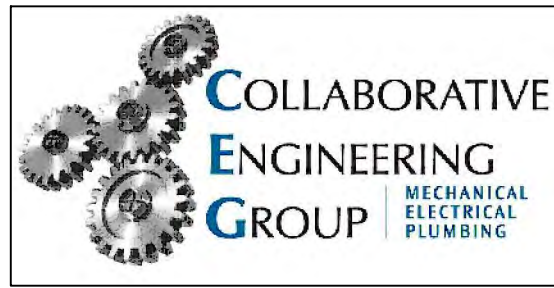

8904 Fairbanks N. Houston, Suite 201
Houston, Texas 77064
281.598.1170
www.collaborative-engr.com
Firm No. F12678

SUNSET COFFEE

1019 Commerce St.
Houston, TX 77002

Ownership of Instruments of Service:
All reports, plans, specifications, computer files, field data, notes & other documents and instruments prepared by BRAVE / ARCHITECTURE as instruments of service shall remain the property of BRAVE / ARCHITECTURE. BRAVE / ARCHITECTURE shall retain all common law, statutory and other reserved rights, including the copyright thereto.

ISSUE:
ISSUE FOR PERMIT 02.25.2016

B/A Project No.: 15137
Drawn By: TLK
Checked By: BBB
Date:
Scale: AS NOTED

ELECTRICAL SPECIFICATIONS

EO.01

DIVISION 26 - ELECTRICAL

260000 ELECTRICAL BASIC REQUIREMENTS:

- A. MINIMUM STANDARDS FOR ALL WORK SHALL BE CITY OF HOUSTON AMENDMENTS TO 2012 INTERNATIONAL BUILDING CODE, 2014 NATIONAL ELECTRICAL CODE, AND ASHRAE 90.1-2007.
- B. REFERENCES: THE STANDARDS MENTIONED HEREIN WILL BE REFERRED TO IN THE DESIGN OF MECHANICAL SYSTEMS. THE ENGINEER WILL SELECT APPROPRIATE SECTIONS OF THE STANDARDS TO BE APPLIED IN ACCORDANCE WITH ESTABLISHED ENGINEERING PRINCIPLES AND PRACTICES.
 - 1. NFPA-70: NATIONAL ELECTRICAL CODE, 2014 EDITION
 - 2. NFPA-101: LIFE SAFETY CODE 101, 2014 EDITION
 - 3. OTHER APPLICABLE SECTIONS OF NFPA
 - 4. TEXAS ACCESSIBILITY STANDARDS (TAS)
 - 5. AMERICANS WITH DISABILITIES ACT (ADA)
- C. SITE CONDITIONS: BEFORE SUBMITTING ANY PROPOSAL, EXAMINE THE PROPOSED SITE AND DETERMINE ANY CONDITIONS THAT MAY AFFECT THE WORK. NO ALLOWANCE SHALL BE MADE FOR FAILURE TO MAKE SUCH EXAMINATIONS.
- D. THE CONTRACTOR IS RESPONSIBLE FOR ALL WORK, MATERIALS, AND LABOR TO SATISFY A COMPLETE WORKING SYSTEM WHETHER SPECIFIED OR IMPLIED.
- E. THE CONTRACTOR IS RESPONSIBLE FOR COORDINATING WITH ALL OTHER TRADES INCLUDING ARCHITECTURAL, STRUCTURAL, CIVIL, MECHANICAL, AND ELECTRICAL.
- F. DO NOT SCALE FROM THE ENGINEERED DRAWINGS. REFER TO THE DIMENSIONED DRAWINGS OF THE ARCHITECT FOR EXACT LOCATIONS OF FIXTURES, EQUIPMENT, ETC.
- G. THE CONTRACTOR SHALL OBTAIN ALL NECESSARY PERMITS AND INSPECTIONS REQUIRED FOR THE INSTALLATION OF WORK AND PAY ALL INCIDENTAL CHARGES.
- H. THE CONTRACTOR SHALL BE RESPONSIBLE FOR PERFORMING ALL TESTS NECESSARY TO PREVENT CONCEALMENT OF DEFECTIVE OR IMPROPER WORK. UPON COMPLETION OF WORK, TEST INSTALLATION THOROUGHLY AND RENDER IT FROM LEAKS OR IMPROPER CONNECTIONS.
- I. PROTECT EQUIPMENT AND WORK FROM DAMAGE DURING HANDLING AND INSTALLATION UNTIL COMPLETION OF CONSTRUCTION. REMOVE ALL EXCESS DEBRIS AND CLEAN ALL EQUIPMENT UPON COMPLETION OF WORK. TOUCH UP WITH PAINT WHERE REQUIRED.
- J. TEMPORARY LIGHTS AND POWER:
 - 1. PROVIDE A TEMPORARY ELECTRICAL LIGHTING AND POWER DISTRIBUTION SYSTEM OF ADEQUATE SIZE TO PROPERLY SERVE THE FOLLOWING REQUIREMENTS, INCLUDING ADEQUATE FEEDER SIZES TO PREVENT EXCESSIVE VOLTAGE DROP. TEMPORARY WORK SHALL BE INSTALLED IN A NEAT AND SAFE MANNER IN ACCORDANCE WITH THE NATIONAL ELECTRICAL CODE, ARTICLE 305, NFPA 241, AND AS REQUIRED BY OSHA OR APPLICABLE LOCAL SAFETY CODES.
- K. IDENTIFICATION OF EQUIPMENT:
 - 1. IDENTIFY ELECTRICAL EQUIPMENT WITH PERMANENTLY ATTACHED BLACK (NORMAL POWER), PHENOLIC PLATES WITH 1/4" WHITE ENGRAVED LETTERING ON THE FACE OF EACH, ATTACHED WITH TWO SHEET METAL SCREWS. COLORS SHALL MATCH EXISTING SCHEME PRESENTLY USED THROUGHOUT THE FACILITY.
- L. WARNING SIGNS:
 - 1. PROVIDE WARNING SIGNS CALLED FOR BY NFPA 70, BY OSHA AND BY THE LIST INCLUDED BELOW.
- M. CONTROL SYSTEMS AND INTERLOCK WIRING:
 - 1. CONTROL SYSTEMS, COMPONENTS AND CONTROL AND INTERLOCK WIRING FOR MECHANICAL EQUIPMENT WILL BE FURNISHED UNDER DIVISION 23. CONTROL DEVICES INCLUDING, BUT NOT LIMITED TO, THERMOSTATS, FAN SPEED AND LEVEL CONTROL SWITCHES, RELAYS AND ELECTRO-PNEUMATIC SWITCHES SHALL BE FURNISHED UNDER DIVISION 23.
 - 2. PROVIDE POWER WIRING TO STARTERS AND CONTACTORS UNDER DIVISION 26. POWER WIRING TO MAGNETIC STARTERS SHALL CONSIST OF WIRING TO THE LINE SIDE TERMINALS OF THE MAGNETIC STARTER OR CONTACTOR AND WIRING AWAY FROM THE LOAD SIDE TERMINALS TO THE EQUIPMENT, EXCEPT WHERE SUCH WIRING IS INSTALLED PRE-WIRED BY THE EQUIPMENT VENDOR SUCH AS FOR ROOFTOP A/C UNITS.
 - a. POWER WIRING TO 120-1-60 AND 277-1-60 VOLT FANS, UNIT HEATERS, FAN-COIL UNITS AND PUMPS SHALL INCLUDE ALL PORTIONS OF THE BRANCH CIRCUIT, EXCEPT WIRING INSIDE AN AUTOMATIC TEMPERATURE CONTROL PANEL (ATC) OR DIRECT DIGITAL CONTROL PANEL (DDC) OR MAGNETIC STARTER. SUCH INTERNAL WIRING SHALL BE FURNISHED UNDER DIVISION 23.
 - 3. UNDER DIVISION 28:
 - a. FURNISH DUCT MOUNTED SMOKE DETECTORS.
 - b. PROVIDE WIRING AMONG DETECTORS, FIRE ALARM SYSTEM, MAGNETIC STARTERS AND RELAYS, ATC PANELS AND DDC PANELS.
 - c. INSTALL LINE VOLTAGE COMPONENTS.
 - 4. SEE CONTROLS SECTION OF DIVISION 23.
- 260519 LOW-VOLTAGE ELECTRICAL POWER CONDUCTORS AND CABLES:
 - A. CONDUCTORS:
 - 1. PROVIDE 98% CONDUCTIVITY COPPER CONDUCTORS WITH 600-VOLT INSULATION.
 - 2. FOR CONDUCTORS NO. 12 AWG AND NO. 10 AWG, PROVIDE STRANDED TYPE THWN OR THHN.
 - 3. FOR CONDUCTORS NO. 14 AWG AND SMALLER, PROVIDE SOLID TYPE THHN. WHERE STRANDED CONDUCTORS ARE USED, MAXIMUM STRANDING SHALL BE 7 FOR #16 AND #18, 19 FOR #14.
 - 4. FOR CONDUCTORS NO. 8 AWG AND LARGER, PROVIDE STRANDED TYPE THHN, OR THWN APPLIED CONSISTENTLY WITH INSULATION RATINGS AND NEC REQUIREMENTS.
 - 5. PROVIDE WHITE OR GRAY COLORED NEUTRAL CONDUCTORS; PROVIDE COLOR CODED PHASE CONDUCTORS.
 - 6. MINIMUM CONDUCTOR SIZE SHALL BE #12 FOR POWER WIRING; #14 FOR HARD WIRED CONTROLS UNLESS OTHERWISE SPECIFIED. PROVIDE DIGITAL COMMUNICATION, NETWORK CABLING, AND OTHER LOW VOLTAGE SYSTEMS WIRING AS DIRECTED ELSEWHERE IN THIS SPECIFICATION.
- 260526 GROUNDING AND BONDING FOR ELECTRICAL SYSTEMS:
 - A. INSTALLATION REQUIREMENTS:
 - 1. GENERAL
 - a. CLEAN ALL CONDUCTIVE SURFACES ON EQUIPMENT TO BE GROUNDING, TO ASSURE GOOD ELECTRICAL CONTINUITY.
 - b. EFFECTIVELY BOND ALL GROUNDING CONDUCTORS TO GROUNDING ELECTRODES, EQUIPMENT ENCLOSURES AND GROUND BUSES.
 - c. LOCATE ALL GROUNDING ATTACHMENTS AWAY FROM AREAS SUBJECT TO PHYSICAL DAMAGE. PROVIDE PROTECTIVE COVERING AS REQUIRED.
 - d. ALL PVC CONDUIT SHALL HAVE SEPARATE GROUND WIRE INSTALLED IN ACCORDANCE WITH TABLE 250-122 OF THE NATIONAL ELECTRICAL CODE.
 - 2. MAIN SWITCHBOARD/BUILDING GROUND:
 - a. MAIN SERVICE SWITCHBOARD SHALL BE BONDED TO INCOMING MAIN WATER LINE WITH HEAVY DUTY GROUND CLAMP IN ACCORDANCE WITH ARTICLE NO. 250-66 OF NATIONAL ELECTRICAL CODE. BONDING CONDUCTOR SHALL BE SIZED IN ACCORDANCE WITH TABLE 250-66 OF NATIONAL ELECTRICAL CODE AND SHALL BE INSULATED.
 - b. BUILDING STEEL SHALL BE CONNECTED TO GROUND BUS ON MAIN SERVICE WITH A CONDUCTOR THE SAME AS SPECIFIED ABOVE.
 - c. GROUNDING ELECTRODE CONDUCTORS SPECIFIED HEREIN SHALL BE INSTALLED WITHOUT CONDUIT, IN GENERAL. WHERE EXPOSED TO POTENTIAL PHYSICAL DAMAGE, INSTALL THE CONDUCTOR IN SCHEDULE 80 PVC.
 - 3. FEEDER/BRANCH CIRCUITS:
 - a. FEEDER CIRCUITS TO PANELS SHALL HAVE A SEPARATE GREEN GROUNDING CONDUCTOR IN CONDUIT SIZED IN ACCORDANCE WITH TABLE 250-122 OF THE NATIONAL ELECTRICAL CODE.
 - b. BRANCH CIRCUITS SHALL HAVE A SEPARATE GREEN GROUNDING CONDUCTOR INSTALLED IN SAME CONDUIT AS PHASE AND NEUTRAL CONDUCTOR FROM PANEL GROUND BUS TO DEVICE. INSTALL AN EQUAL NUMBER OF GROUNDING AND NEUTRAL CONDUCTORS. THE GROUNDING CONDUCTOR SHALL BE SIZED IN ACCORDANCE WITH TABLE 250-122 OF THE NATIONAL ELECTRICAL CODE.
 - c. BOND THE RECEPTACLE GROUND PIN TO ITS BOX USING A BONDING JUMPER, EXCEPT WHERE ISOLATED GROUND RECEPTACLES ARE REQUIRED.
 - d. FLEXIBLE CONDUIT WILL NOT BE APPROVED AS A GROUNDING MEANS. FLEXIBLE CONDUIT SHALL HAVE A JUMPER WIRE SIZED TO AMPACITY OF BRANCH BREAKER AND CONNECTED TO CONDUIT SYSTEM ON BOTH ENDS. THIS APPLIES TO FIXTURES, MOTORS, CONTROLS AND OTHER DEVICES.
 - 4. TRANSFORMERS:
 - a. GROUND SECONDARY NEUTRAL OF TRANSFORMERS TO GROUNDING CONDUCTOR IN PRIMARY FEEDER, SIZED IN ACCORDANCE WITH TABLE 250-66 OF THE NATIONAL ELECTRICAL CODE, AND TO GROUNDING ELECTRODE SYSTEM AS INDICATED ON THE DRAWINGS, COLD WATER MAIN, 1 1/2 INCH OR LARGER, BOND ACROSS ANY DIELECTRIC UNIONS BETWEEN POINT OF CONNECTION AND DOMESTIC WATER ENTRANCE.
- 260529 HANGERS AND SUPPORTS FOR ELECTRICAL SYSTEMS:
 - A. ACCEPTABLE MANUFACTURERS:
 - 1. ERICO PRODUCTS, INC.
 - 2. STEEL CITY.
 - 3. MINERALLAC.
 - 4. RAYCO FASTENERS.
 - B. TYPES OF SUPPORTING DEVICES:
 - 1. PROVIDE A COMPLETE SYSTEM OF SUPPORTING DEVICES AND HANGERS FOR SUPPORT OR BRACING OF CONDUIT, ELECTRICAL EQUIPMENT.
- 260533 RACEWAY AND BOXES FOR ELECTRICAL SYSTEMS:
 - A. ACCEPTABLE MANUFACTURERS FOR RACEWAYS AND CONDUIT:
 - 1. EMT, IMC, AND RIGID CONDUIT SHALL BE HOT DIPPED, GALVANIZED, OR ELECTROGALVANIZED STEEL BY ALLIED, GENERAL ELECTRIC, REPUBLIC, TRIANGLE, OR WHEATLAND.
 - 2. SURFACE METAL RACEWAYS SHALL BE WIREMOLD.
 - 3. ASSOCIATED COUPLINGS, CONNECTORS AND FITTINGS SHALL BE STEEL AS MANUFACTURED BY RACO OR EQUIVALENT.

- 4. ERICKSON COUPLINGS SHALL BE USED WHERE NEITHER LENGTH OF CONDUIT CAN BE ROTATED.
- 5. EMT BOX CONNECTORS SHALL BE SET SCREW OR COMPRESSION FITTINGS.
- 6. CONDUIT, CONNECTORS, COUPLINGS AND FITTINGS SHALL BE UL LISTED AND LABELED.
- B. ELECTRICAL METALLIC TUBING (EMT):
 - 1. USE ELECTRIC METALLIC TUBING (EMT) WHERE DRAWINGS CALL FOR CONDUIT TO BE:
 - a. CONCEALED IN WALLS.
 - b. INSTALLED ABOVE SUSPENDED CEILING.
 - c. INSTALLED EXPOSED, ABOVE 6 FEET.
- C. INTERMEDIATE METAL CONDUIT (IMC):
 - 1. USE INTERMEDIATE METAL CONDUIT (IMC) WHERE DRAWINGS CALL FOR CONDUIT TO BE:
 - a. INSTALLED IN HAZARDOUS AREAS.
 - b. INSTALLED IN CONCRETE SLABS AT GROUND FLOOR.
 - c. INSTALLED EXPOSED BELOW 6 FEET.
 - d. INSTALLED IN WET LOCATIONS.
- D. RIGID STEEL CONDUIT (RSC):
 - 1. USE RIGID STEEL CONDUIT WHERE DRAWINGS CALL FOR CONDUIT TO BE:
 - 2. EXPOSED TO SEVERE MECHANICAL DAMAGE.
- E. FLEXIBLE METAL CONDUIT:
 - 1. PROVIDE FLEXIBLE METAL CONDUIT FOR TERMINATION AT EQUIPMENT SUBJECT TO MOTION AND VIBRATION.
 - 2. CONDUIT SHALL BE ELECTRICALLY CONTINUOUS FROM OUTLET OR CONDUIT END TO UTILIZATION EQUIPMENT.
 - 3. LENGTH SHALL NOT EXCEED 6 FEET.
 - 4. MAXIMUM LENGTH CONCEALED IN WALLS SHALL BE 3 FEET.
 - 5. WHERE EXPOSED TO CONTINUOUS OR INTERMITTENT MOISTURE, CONDUIT SHALL BE LIQUID TIGHT.
- F. ACCEPTABLE MANUFACTURERS FOR OUTLET BOXES: NATIONAL, APPLETON, RACO, GENERAL ELECTRIC, STEEL CITY.

- 260544 SLEEVES AND SLEEVE SEALS FOR ELECTRICAL RACEWAYS AND CABLING:
 - A. PROVIDE U.L. LISTED FIRESTOP SEALING SYSTEMS AT ALL ELECTRICAL PENETRATIONS OF RATED FLOORS AND WALLS.

- 262726 WIRING DEVICES:
 - A. ACCEPTABLE MANUFACTURERS:
 - 1. ARROW HART B. EAGLE
 - 2. HUBBELL D. LEVITON
 - 3. PASS AND SEYMOUR.
 - 4. LEVITON NUMBERS ARE USED UNLESS OTHERWISE NOTED, BUT PRODUCTS OF EQUIVALENT QUALITY BY NAMED MANUFACTURERS WILL BE ACCEPTABLE.
 - B. SWITCHES:
 - 1. 15-AMP, 120/277 VAC:
 - a. SINGLE POLE: LEVITON NO. 1201-1.
 - b. THREE-WAY: LEVITON NO. 1203-1.
 - c. SINGLE POLE, WEATHERPROOF: LEVITON NO. 1201 WITH STEEL CITY NO. SWI-C WEATHERPROOF PLATE.
 - d. SINGLE POLE WITH PILOT LIGHT (120 VAC); LEVITON NO. 1201-PL.
 - 2. INCANDESCENT DIMMERS:
 - a. INCANDESCENT DIMMERS: LEVITON SERIES 60,000, 120-VOLT, 800, 1000, 1500, OR 2000 WATTS AS REQUIRED FOR LOAD.
 - C. RECEPTACLES:
 - 1. 20-AMP, 125 VAC RECEPTACLES:
 - a. LEVITON NO. 5362.
 - D. MISCELLANEOUS DEVICES:
 - 1. MANUAL MOTOR STARTER WITH THERMAL UNIT: SQUARE "D" CLASS 2510.

- 262816 ENCLOSED SWITCHES AND CIRCUIT BREAKERS:
 - A. ACCEPTABLE MANUFACTURERS:
 - 1. SQUARE D.
 - 2. G.E.
 - 3. CUTLER-HAMMER/WESTINGHOUSE.
 - 4. PROVIDE SQUARE D SERIES HU-860, SIX-POLE SAFETY SWITCHES FOR PART-WINDING OR TWO-SPEED MOTORS REQUIRING REMOTE DISCONNECTS.

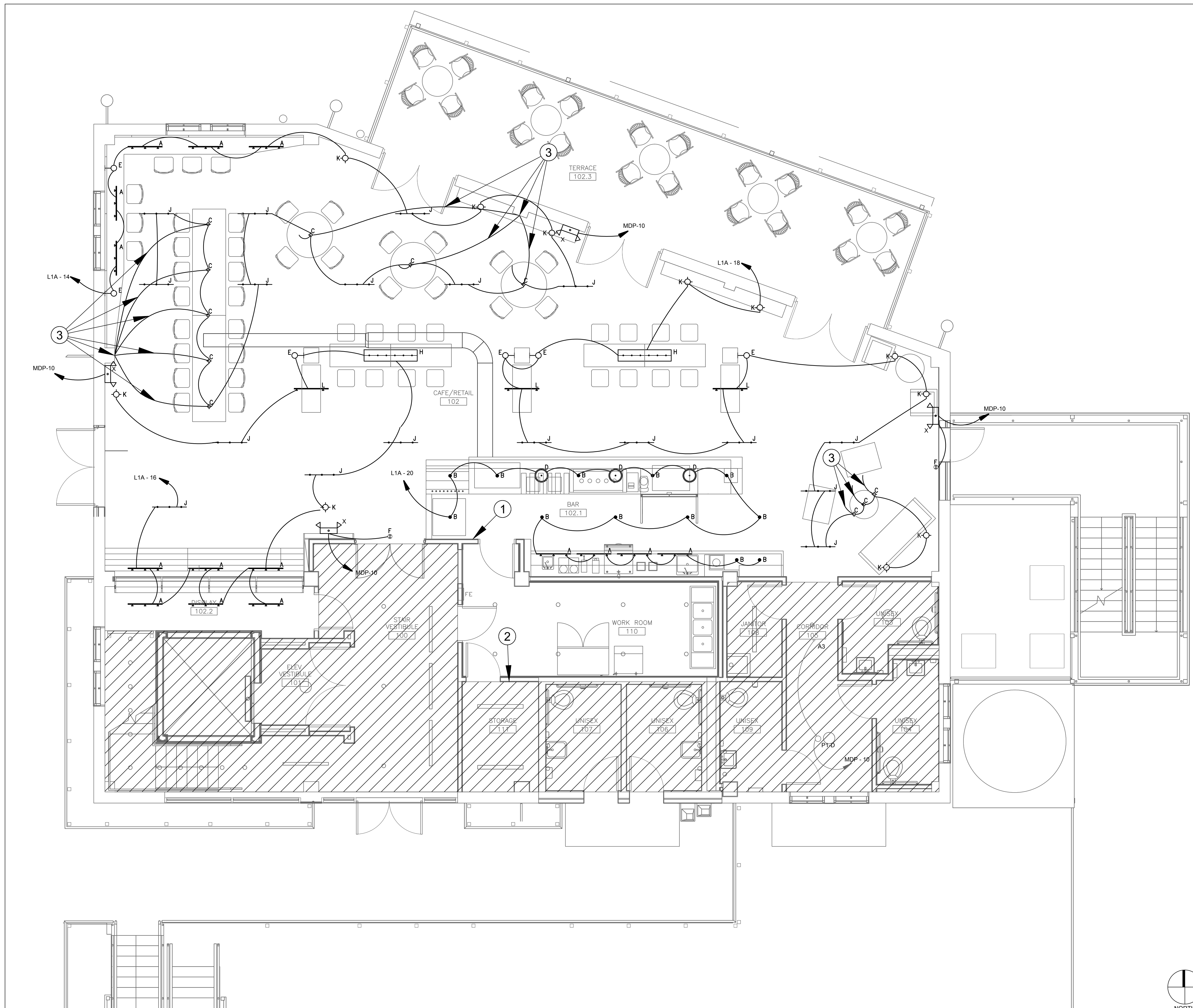

GENERAL NOTES

- A. LIGHTING TO BE CONTROLLED BY DIMMER PANEL REFER TO LIGHTING CONTROL DIAGRAM ON SHEET E9.00
- B. EMERGENCY FIXTURES TO BE CONNECTED TO UNSWITCHED CONDUCTOR ON SPECIFIED CIRCUIT.

KEY NOTES

1. PROVIDE LIGHTING CONTROL STATION. REFER TO LIGHTING CONTROL DIAGRAM ON SHEET E9.00.
2. PROVIDE DIMMER PANEL. REFER TO LIGHTING CONTROL DIAGRAM ON SHEET E9.00.
3. TYPE C FIXTURES TO BE ATTACHED FROM WALL OR CEILING. REFER TO ARCHITECTURAL DRAWINGS.



BRAVE / ARCHITECTURE

4617 Montrose Blvd., Suite C.230
 Houston, Texas 77006
 Voice: 713.524.5858
 Fax: 713.524.5868
 studio@bravearchitecture.com
 Contact: Silvana Micolich
 smicolich@bravearchitecture.com

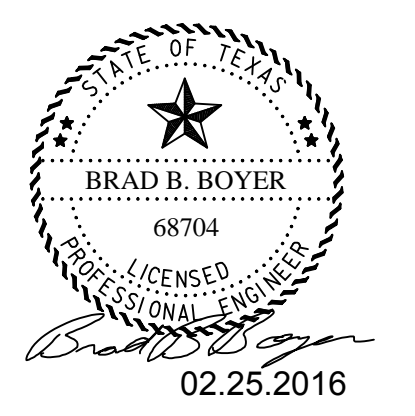

Consultants:

MEP:
 Collaborative Engineering Group
 8904 Fairbanks N. Houston Suite 201
 Houston, TX 77064
 T: 281.598.1170
 F: 281.598.1130



8904 Fairbanks N. Houston, Suite 201
 Houston, Texas 77064
 281.598.1170
 www.collaborative-engr.com
 Firm No. F12678

SUNSET COFFEE

1019 Commerce St.
 Houston, TX 77002

Ownership of Instruments of Service:
 All reports, plans, specifications, computer files, field data, notes & other documents and instruments prepared by BRAVE / ARCHITECTURE as instruments of service shall remain the property of BRAVE / ARCHITECTURE. BRAVE / ARCHITECTURE shall retain all common law, statutory and other reserved rights, including the copyright thereto.

ISSUE:
 ISSUE FOR PERMIT 02.25.2016

B/A Project No.: 15137
 Drawn By: TLK
 Checked By: BBB
 Date:
 Scale: AS NOTED

ELECTRICAL LIGHTING FLOOR PLAN

ELECTRICAL LIGHTING FLOOR PLAN

1/4" = 1'- 0" 1

E1.01

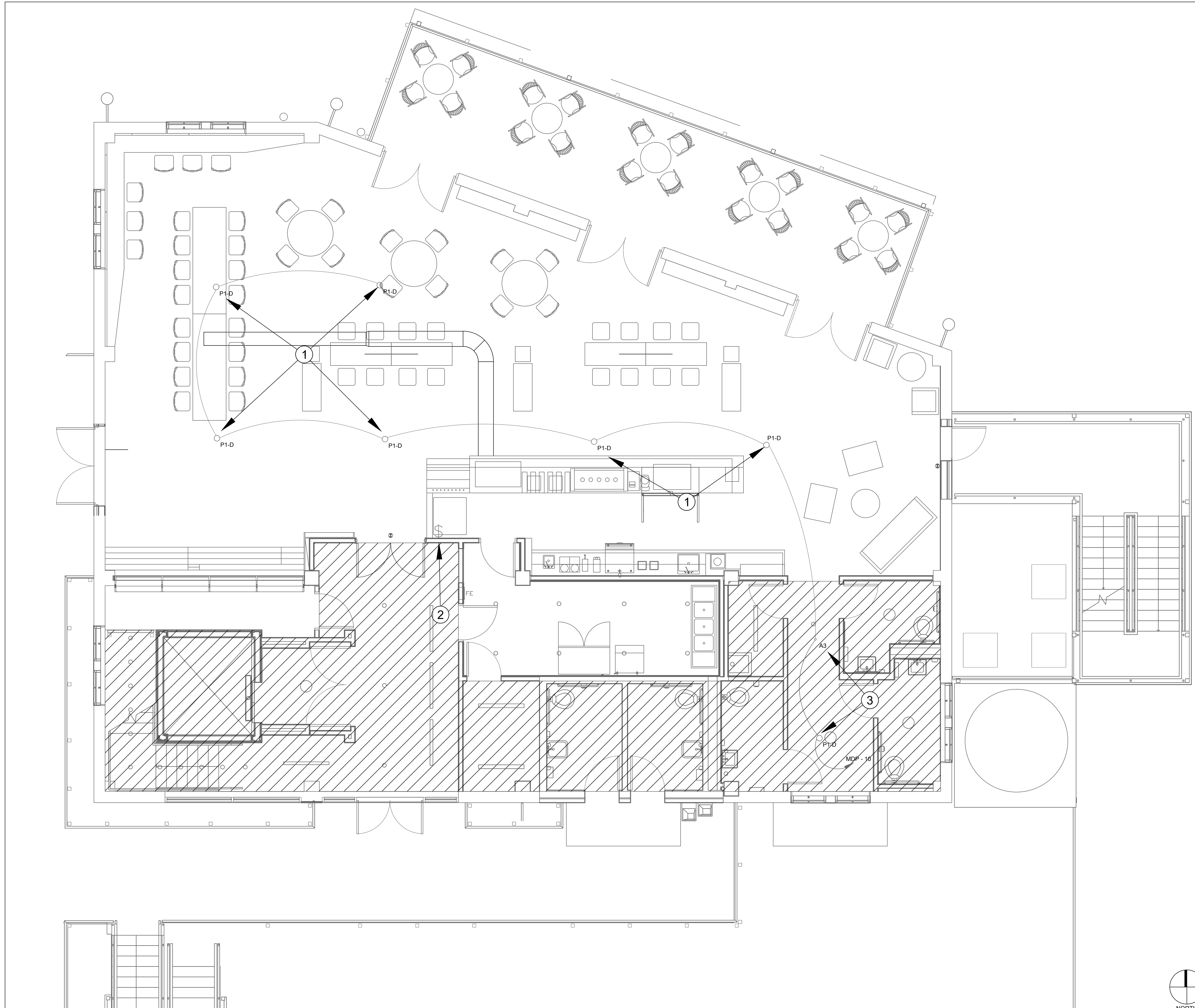

GENERAL NOTES

KEY NOTES

1. EXISTING FIXTURES TO BE REMOVED.
2. EXISTING DATA LINE SWITCH TO BE REMOVED.
3. EXISTING FIXTURES TO REMAIN.

ELECTRICAL LIGHTING DEMOLITION PLAN

1/4" = 1'- 0" 1



BRAVE / ARCHITECTURE

4617 Montrose Blvd., Suite C.230
 Houston, Texas 77006
 Voice: 713.524.5858
 Fax: 713.524.5868
 studio@bravearchitecture.com
 Contact: Silvana Micolich
 smicolich@bravearchitecture.com

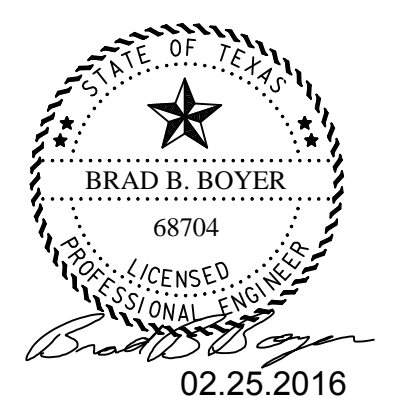

Consultants:

MEP:

Collaborative Engineering Group
 8904 Fairbanks N. Houston Suite 201
 Houston, TX 77064
 T: 281.598.1170
 F: 281.598.1130

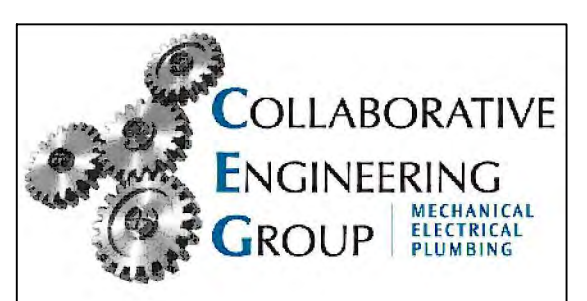

8904 Fairbanks N. Houston, Suite 201
 Houston, Texas 77064
 281.598.1170
 www.collaborative-engr.com
 Firm No. F12678

SUNSET COFFEE

1019 Commerce St.
 Houston, TX 77002

Ownership of Instruments of Service:
 All reports, plans, specifications, computer files, field data, notes & other documents and instruments prepared by BRAVE / ARCHITECTURE as instruments of service shall remain the property of BRAVE / ARCHITECTURE. BRAVE / ARCHITECTURE shall retain all common law, statutory and other reserved rights, including the copyright thereto.

ISSUE:
 ISSUE FOR PERMIT 02.25.2016

B/A Project No.: 15137
 Drawn By: TLK
 Checked By: BBB
 Date:
 Scale: AS NOTED

ELECTRICAL LIGHTING DEMOLITION PLAN

E1.11

P:\Projects\01152016\025-000 Sunset Coffee Shop\E1.01.dwg, 2/26/2016 11:29:47 AM, Rev. ARCH (in bleed) D (24.00 x 36.00 inches), 1:1

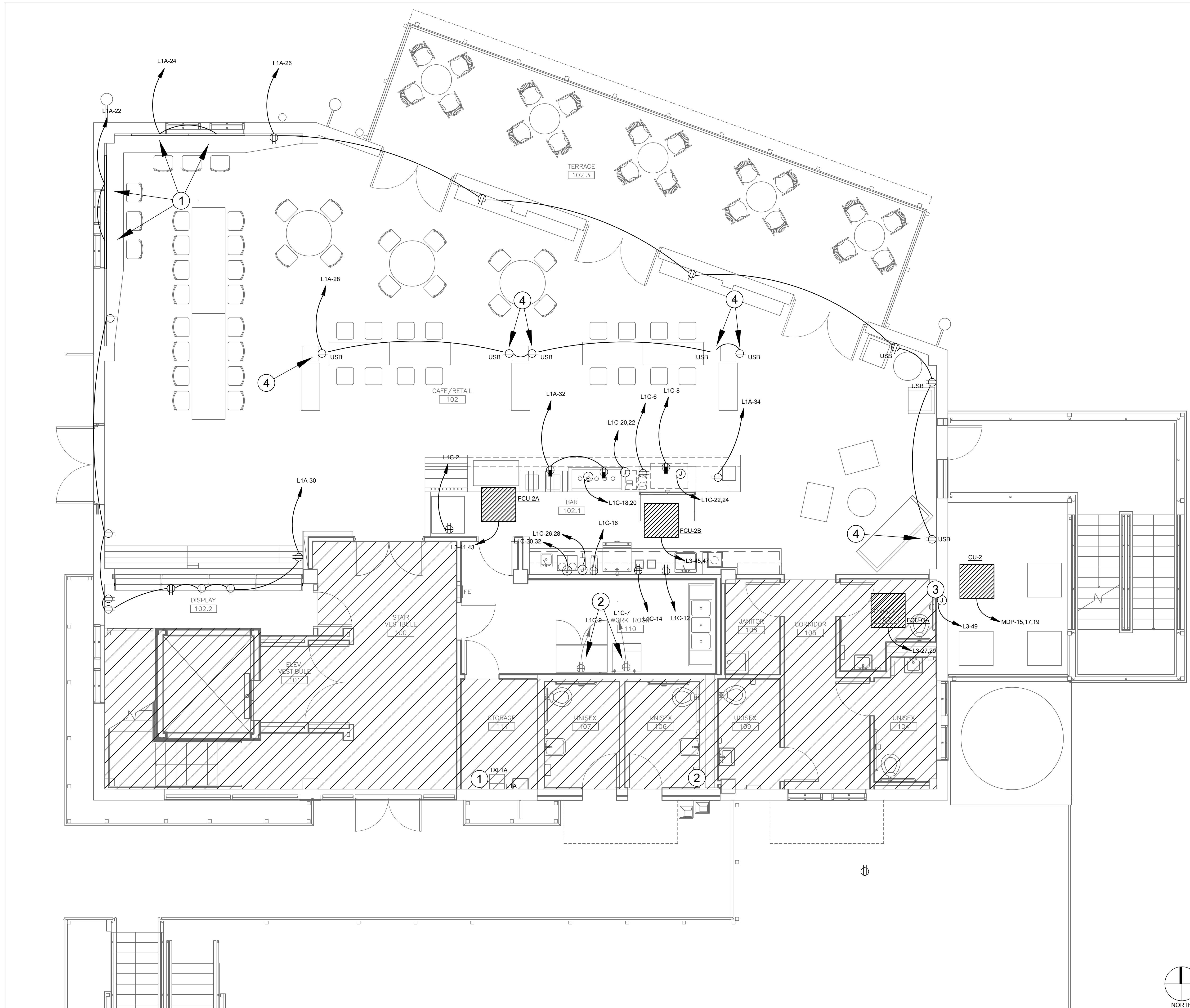

GENERAL NOTES

- A. EXISTING FIRE ALARM SYSTEM TO REMAIN. FIRE ALARM DEVICES TO BE MOVED TO ACCOMMODATE NEW CEILING. REFER TO ARCHITECTURAL DRAWINGS.
- B. CONTRACTOR TO VERIFY LOCATION AND MOUNTING HEIGHT OF ALL RECEPTACLES AND J-BOXES.
- C. PROVIDE LOCAL DISCONNECTING MEANS FOR ALL HVAC EQUIPMENT.
- D. OUTLETS MARKED "USB" TO BE HUBBELL USB20X2 OR APPROVED EQUAL.

KEY NOTES

- 1. ALTERNATE RECEPTACLE OUTLETS AND USB OUTLETS IN WIREMOLD.
- 2. EXISTING PANEL L1A LOCATED HERE ON FLOOR ABOVE.
- 3. MOTORIZED DAMPER, REFER TO MECHANICAL DRAWINGS.
- 4. EXISTING TO REMAIN. RE-CIRCUIT AND CHANGE DEVICE AS INDICATED. COORDINATE OUTLET LOCATION WITH FURNITURE AND ARCHITECTURAL DRAWINGS.



BRAVE / ARCHITECTURE
 4617 Montrose Blvd., Suite C.230
 Houston, Texas 77006
 Voice: 713.524.5858
 Fax: 713.524.5868
 studio@bravearchitecture.com
 Contact: Silvana Micolich
 smicolich@bravearchitecture.com

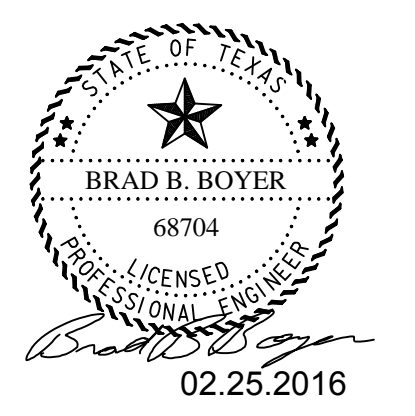

Consultants:

MEP:

Collaborative Engineering Group
 8904 Fairbanks N. Houston Suite 201
 Houston, TX 77064
 T: 281.598.1170
 F: 281.598.1130

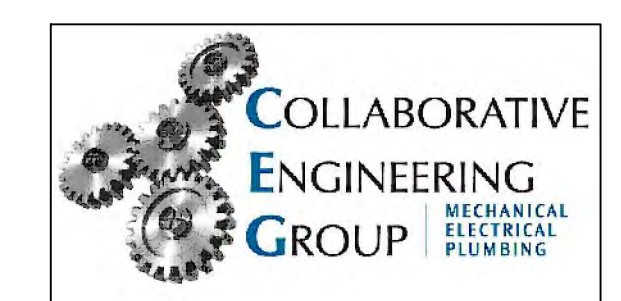

8904 Fairbanks N. Houston, Suite 201
 Houston, Texas 77064
 281.598.1170
 www.collaborative-engr.com
 Firm No. F12678

SUNSET COFFEE

1019 Commerce St.
 Houston, TX 77002

Ownership of Instruments of Service:
 All reports, plans, specifications, computer files, field data, notes & other documents and instruments prepared by BRAVE / ARCHITECTURE as instruments of service shall remain the property of BRAVE / ARCHITECTURE. BRAVE / ARCHITECTURE shall retain all common law, statutory and other reserved rights, including the copyright thereto.

ISSUE FOR PERMIT 02.25.2016

B/A Project No.: 15137
 Drawn By: TLK
 Checked By: BBB
 Date:
 Scale: AS NOTED

ELECTRICAL POWER FLOOR PLAN

E2.01

ELECTRICAL POWER FLOOR PLAN

1/4" = 1'-0" 1

P:\Projects\01152016\025-000 Sunset Coffee Shop\E201.dwg, 2/26/2016 11:39:49 AM, Rev. ARCH (in bleed) D (24.00 x 36.00 inches), 1:1

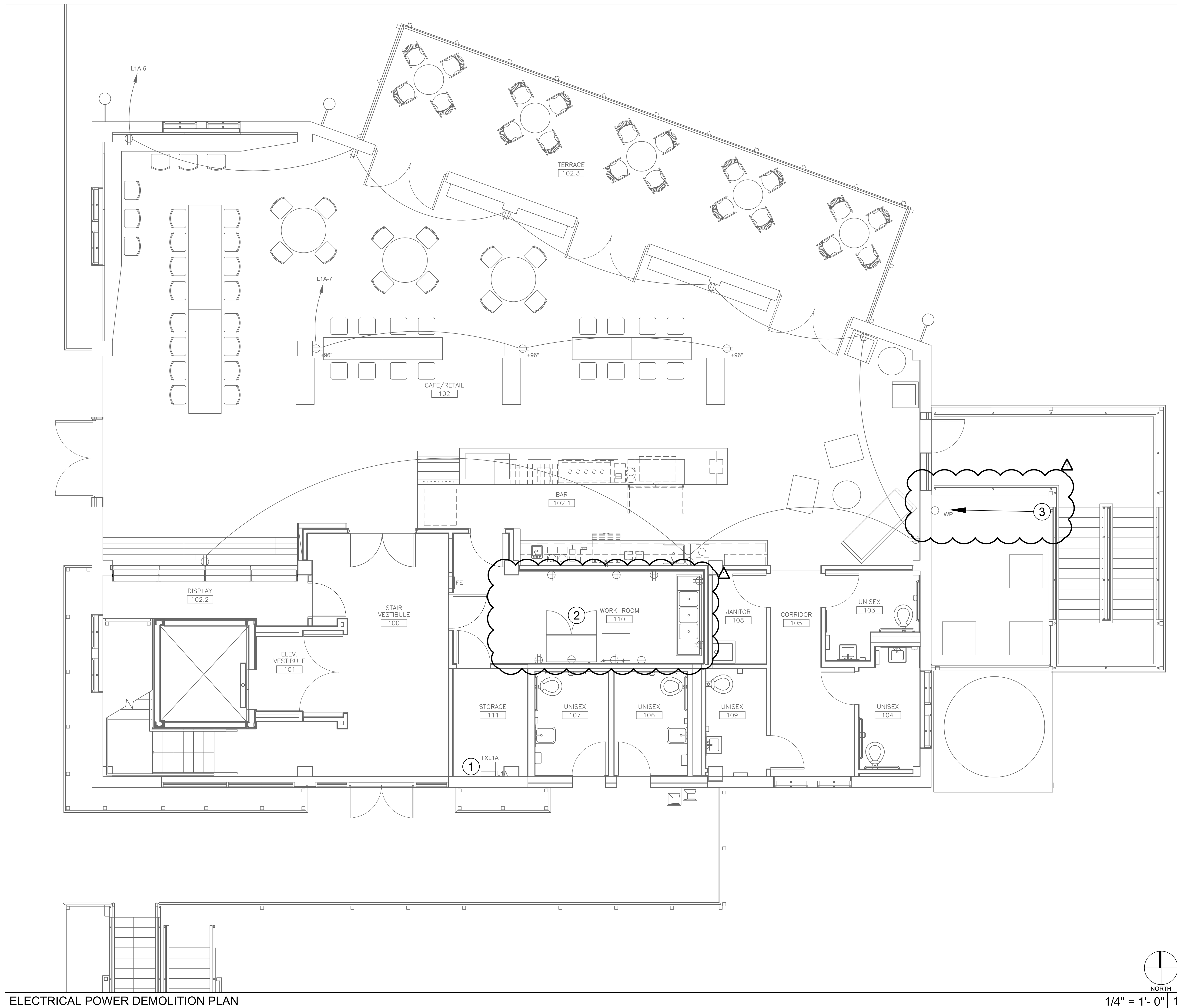

GENERAL NOTES

- A. EXISTING RECEPTACLES AND CIRCUITS TO BE REMOVED, UNLESS OTHERWISE NOTED.
- B. RE-USE CONDUIT AND BOXES WHEN POSSIBLE.

KEY NOTES

- 1. EXISTING TRANSFORMER AND PANEL L1C TO REMAIN.
- 2. EXISTING RECEPTACLES TO REMAIN IN RM 110.
- 3. EXISTING RECEPTACLE TO REMAIN.



BRAVE / ARCHITECTURE

4617 Montrose Blvd., Suite C.230
 Houston, Texas 77006
 Voice: 713.524.5858
 Fax: 713.524.5868
 studio@bravearchitecture.com
 Contact: Silvana Micolich
 smicolich@bravearchitecture.com

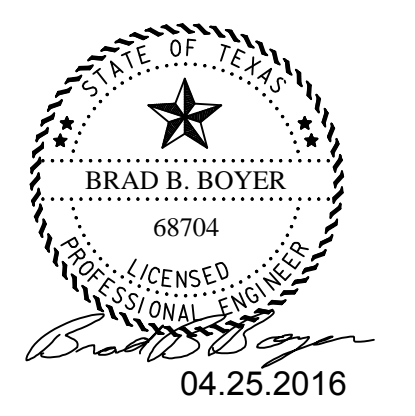

Consultants:

MEP:
 Collaborative Engineering Group
 8904 Fairbanks N. Houston Suite 201
 Houston, TX 77064
 T: 281.598.1170
 F: 281.598.1130



8904 Fairbanks N. Houston, Suite 201
 Houston, Texas 77064
 281.598.1170
 www.collaborative-engr.com
 Firm No. F12678

SUNSET COFFEE

1019 Commerce St.
 Houston, TX 77002

Ownership of Instruments of Service:
 All reports, plans, specifications, computer files, field data, notes & other documents and instruments prepared by BRAVE / ARCHITECTURE as instruments of service shall remain the property of BRAVE / ARCHITECTURE. BRAVE / ARCHITECTURE shall retain all common law, statutory and other reserved rights, including the copyright thereto.

ISSUE:
 ISSUE FOR PERMIT 02.25.2016
 PERMIT RESPONSES 04.25.2016

B/A Project No.: 15137
 Drawn By: TLK
 Checked By: BBB
 Date:
 Scale: AS NOTED

ELECTRICAL POWER DEMOLITION PLAN

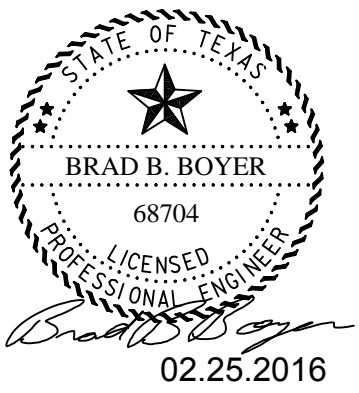

Consultants:

MEP:

Collaborative Engineering Group
8904 Fairbanks N. Houston Suite 201
Houston, TX 77064
T: 281.598.1170
F: 281.598.1130



8904 Fairbanks N. Houston, Suite 201
Houston, Texas 77064
281.598.1170
www.collaborative-engr.com
Firm No. F12678

SUNSET COFFEE

1019 Commerce St.
Houston, TX 77002

Ownership of Instruments of Service:
All reports, plans, specifications, computer files, field data, notes & other documents and instruments prepared by BRAVE / ARCHITECTURE as instruments of service shall remain the property of BRAVE / ARCHITECTURE. BRAVE / ARCHITECTURE shall retain all common law, statutory and other reserved rights, including the copyright thereto.

ISSUE FOR PERMIT 02.25.2016

B/A Project No.: 15137
Drawn By: TLK
Checked By: BBB
Date:
Scale: AS NOTED

ELECTRICAL ONE LINE, LOAD ANALYSIS & FAULT ANALYSIS

SUNSET COFFEE SHOP	SERVICE CALCULATION ADDITION TO EXISTING 277/480V SERVICE				
	Sq Ft	VA	LINE A AMPS	LINE B AMPS	LINE C AMPS
EXISTING LOAD		267951	322	322	322
LIGHTING AT 2 VA @ 125%	2600	6500	8	8	8
NEW LIGHTING @ 3018VA (OMIT)					
RECEPT @ 1VA = 2600 (OMIT)					
NEW RECEPT @ 50%		3300	4	4	4
KITCHEN EQUIPMENT		26950	32	32	32
NEW EQUIPMENT		13891	17	17	17
LARGEST MOTOR @25%		9162	11	11	11
Totals		327754	394	394	394
EXISTING CAPACITY (400A)		332554	400	400	400
SPARE CAPACITY AFTER RENOVATION			6	6	6

***SERVICE IS ADEQUATE

SUNSET COFFEE SHOP	XFMR TXL1 LOAD CALCULATION 120/208V					
	Sq Ft	VA	Line A Amps	Line B Amps	Line C Amps	Neutral Amps
Lights & Receptacles						
EXISTING EQUIPMENT		30111	84	84	84	84
GENERAL LIGHTING @ 2VA @125%	2600	6500	18	18	18	18
ACTUAL LIGHTING @ 9646 VA (OMIT)						
RECEPTACLES @ 180VA EA. @50%		3330	9	9	9	9
RECEPTACLES @ 1VA	3950					
EQUIPMENT		500	1	1	1	1
Totals		40441	112	112	112	112
TRANSFORMER CAPACITY - 45KVA		45000	125	125	125	125
REMAINING CAPACITY			12	12	12	12

*** TRANSFORMER IS ADEQUATE

SUNSET COFFEE SHOP	TRANSFORMER TXL1A LOAD CALCULATION					
	Sq Ft	VA	Line A Amps	Line B Amps	Line C Amps	Neutral Amps
Lights & Receptacles						
EXISTING EQUIPMENT		10300	29	29	29	29
Kitchen Loads @ 65% 220.88		13891	39	39	39	39
NEW EQUIPMENT		5580	15	15	15	15
Totals		29771	83	83	83	83
Transformer Capacity - 30KVA		30000	83	83	83	83
Remaining Capacity		230	1	1	1	1

*** TRANSFORMER IS ADEQUATE

SUNSET COFFEE SHOP	TRANSFORMER TXL3 LOAD CALCULATION 120/208V				
	VA	Line A Amps	Line B Amps	Line C Amps	Neutral Amps
Lights & Receptacles					
EXISTING EQUIPMENT	80437	223	223	223	223
EQUIPMENT	13909	39	39	39	39
FCU - 2A					
FCU - 2B					
FCU - OA					
CU - 2					
Totals	94346	262	262	262	262
Transformer Capacity - 112.5KVA	112500	312	312	312	312
Remaining Capacity		50	50	50	50

*** TRANSFORMER IS ADEQUATE

Fault Current Summary		
Location	Voltage	Amps Sym
Utility	480/277	21300
PNL MDP	480/277	14150
PNL L1A	208/120	3100
PNL L1C	208/120	1600
PNL L3	208/120	6250

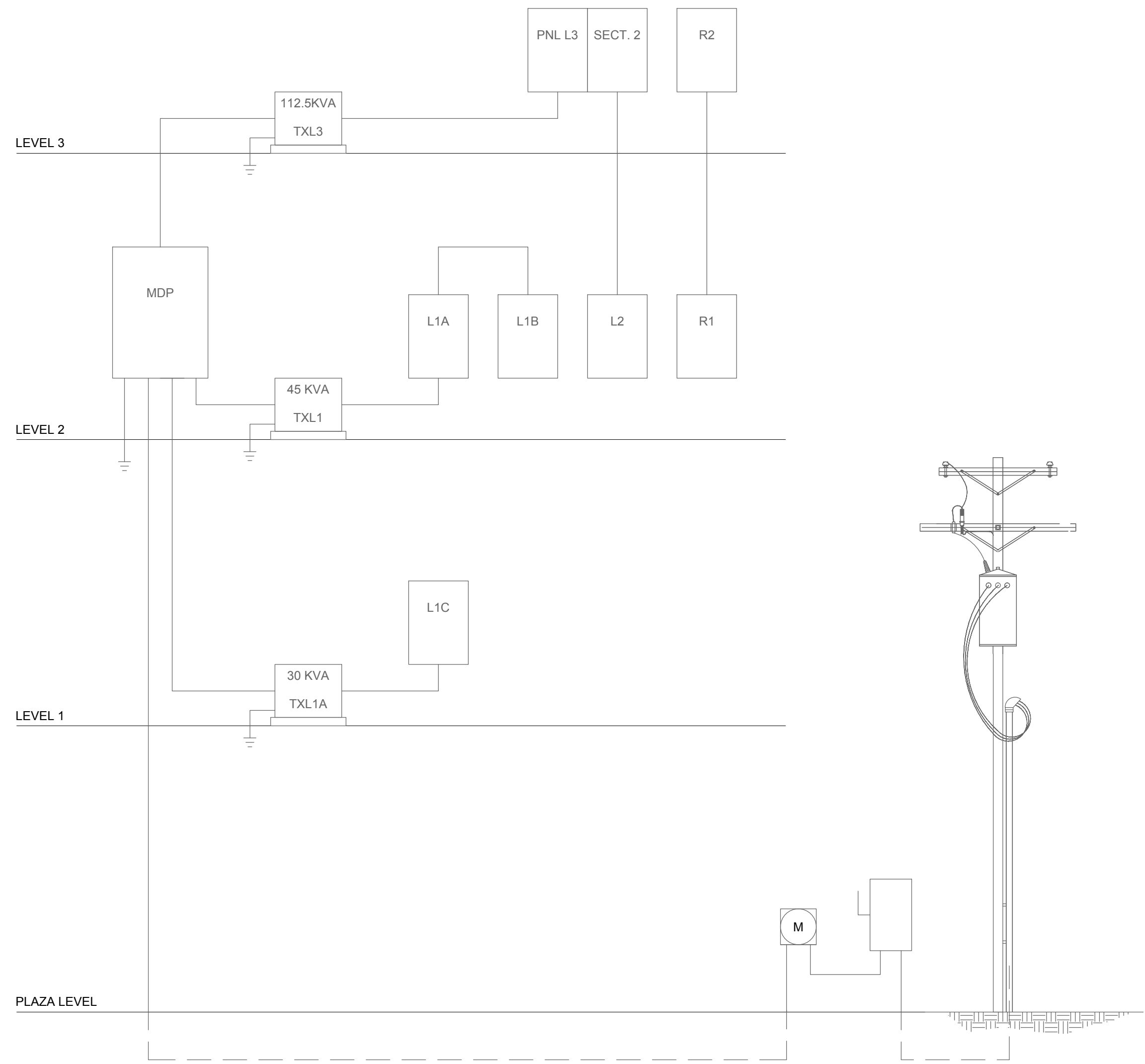

FOR REFERENCE ONLY

GENERAL NOTES

A. CONTRACTOR TO FIELD VERIFY NUMBER AND LOCATION OF EXISTING SPARES.



BRAVE / ARCHITECTURE

4617 Montrose Blvd., Suite C.230
Houston, Texas 77006
Voice: 713.524.5858
Fax: 713.524.5868
studio@bravearchitecture.com
Contact: Silvana Micolich
smicolich@bravearchitecture.com

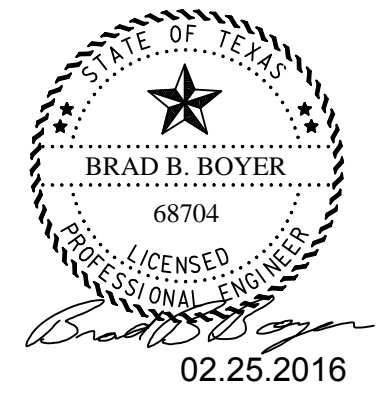

02.25.2016

Consultants:

MEP:

Collaborative Engineering Group
8904 Fairbanks N. Houston Suite 201
Houston, TX 77064
T: 281.598.1170
F: 281.598.1130

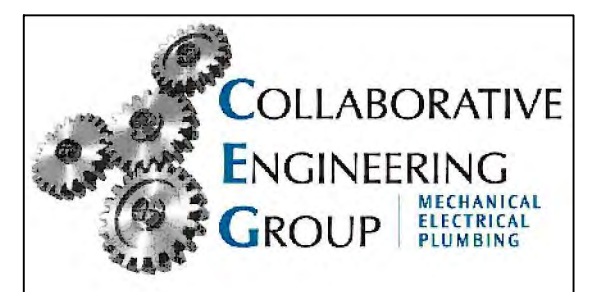

8904 Fairbanks N. Houston, Suite 201
Houston, Texas 77064
281.598.1170
www.collaborative-engr.com
Firm No. F12578

SUNSET COFFEE

1019 Commerce St.
Houston, TX 77002

Ownership of Instruments of Service:
All reports, plans, specifications, computer files, field data, notes & other documents and instruments prepared by BRAVE / ARCHITECTURE as instruments of service shall remain the property of BRAVE / ARCHITECTURE. BRAVE / ARCHITECTURE shall retain all common law, statutory and other reserved rights, including the copyright thereto.

ISSUE:
ISSUE FOR PERMIT 02.25.2016

B/A Project No.: 15137
Drawn By: TLK
Checked By: BBB
Date:
Scale: AS NOTED

ELECTRICAL SCHEDULES

E8.00

277/480 VOLT, 3 PHASE, 4 WIRE											MOUNTED: SURFACE	
400A MLO EXISTING											KAIC: SEE FAULT ANALYSIS ON ONE LINE	
VA	Circuit	WIRE	TRIP AMPS	CCT	LINE A AMPS	LINE B AMPS	LINE C AMPS	CCT	TRIP AMPS	WIRE	Circuit	VA
3000	EXISTING			1	10.8	10.8			2		EXISTING	3000
3000	EXISTING			3		10.8	10.8		4		EXISTING	3000
3000	EXISTING			5			10.8	10.8	6		EXISTING	3000
27018	EXISTING			7	32.5	14.7			8		EXISTING	4076
---	---			9		32.5	0.4		10		LTG LEVEL 1 (EXISTING)	100
---	---			11					12		EXISTING	3030
500	EXISTING			13	1.8	10.7			14		EXISTING	2970
17292	CU-2	10	35	15		20.8	5.9		16		EXISTING	1624
---	---	10	---	17			20.8	2.8	18		EXISTING	778
---	---	10	---	19	20.8	36.1			20		EXISTING- WATER HEATER	30000
---	SPARE (EXISTING)			21		---	36.1		22		---	---
---	SPARE (EXISTING)			23		---	36.1	24	---		---	---
---	SPARE (EXISTING)			25	---	---			26		SPARE (EXISTING)	---
---	SPARE (EXISTING)			27	---	---			28		SPARE (EXISTING)	---
---	SPARE (EXISTING)			29	---	---			30		SPARE (EXISTING)	---
---	SPARE (EXISTING)			31	---	38.1			32		PNL L1C (EXISTING)	31670
---	SPARE (EXISTING)			33		---	38.1		34		---	---
---	SPARE (EXISTING)			35		---	38.1		36		---	---
36745	PNL L1A (EXISTING)			37	44.2	106.3			38		EXISTING	88358
---	---			39		44.2	106.3		40		---	---
---	---			41			44.2	106.3	42		---	---
		Total Amps:		327		306		313				

Load Classification	Connected Load	Demand Factors (%)	Estimated Demand	Panel Totals
Equipment	17292	100%	17292	Total Connected Load: 262.2 kVA
Kitchen	21370	100%	21370	Total Estimated Demand Load: 314.2 kVA
Lighting	3018	50%	1508.75	Total Connected: 315 A
Receptacles	6120	100%	6120	Total Estimated Demand: 378 A
Existing Load	214361	125%	267951.25	

NOTES:

120/208 VOLT, 3 PHASE, 4 WIRE											MOUNTED: SURFACE	
100A MLO EXISTING											KAIC: SEE FAULT ANALYSIS ON ONE LINE	
VA	Circuit	WIRE	TRIP AMPS	CCT	LINE A AMPS	LINE B AMPS	LINE C AMPS	CCT	TRIP AMPS	WIRE	Circuit	VA
850	EXISTING			1	4.1	11.0			2		BEVERAGE CASE	1320
---	---			3		4.1			4		SPARE	---
540	EXISTING			5			4.5	7.5	6	20	MAZZER GRINDER	900
1650	ICE MAKER			7	13.8	9.2			8	20	UNDERCOUNTER REFRIGERATOR	1100
700	REFRIGERATOR			9		5.8			10		SPARE	---
2025	EXISTING			11			16.9	15.0	12	20	BLENDER	1800
2025	EXISTING			13	16.9	15.0			14	20	BLENDER	1800
1500	EXISTING			15		12.5	9.0		16	20	"BUNN" GRINDER	1080
1500	EXISTING			17			12.5	14.4	18	20	UNDERCOUNTER BOILER	3000
1500	EXISTING			19	12.5	14.4			20	---	---	---
360	EXISTING			21		3.0	23.6		22	30	ESPRESSO MACHINE	4900
---	SPARE (EXISTING)			23		---	23.6		24	---	---	---
---	SPARE (EXISTING)			25	---	19.2			26	30	HOT WATER TOWER	4000
---	SPARE (EXISTING)			27	---	---	19.2		28	---	---	---
---	SPARE (EXISTING)			29	---	---	22.6		30	30	BREWING MACHINE	4700
---	SPARE (EXISTING)			31	---	22.6			32	---	---	---
---	SPARE (EXISTING)			33		---	---		34		SPACE	---
---	SPARE (EXISTING)			35		---	---		36		SPACE	---
---	SPARE (EXISTING)			37		---	---		38		SPACE	---
---	SPARE (EXISTING)			39		---	---		40		SPACE	---
---	SPARE (EXISTING)			41		---	---		42		SPACE	---
		Total Amps:		139		77		117				

Load Classification	Connected Load	Demand Factors (%)	Estimated Demand	Panel Totals
Equipment	5580	100%	5580	Total Connected Load: 37.3 kVA
Kitchen	21370	65%	13890.5	Total Estimated Demand Load: 32.3 kVA
Lighting	0	N/A	0	Total Connected: 104 A
Receptacles	0	N/A	0	Total Estimated Demand: 90 A
Existing Load	10300	125%	12875	

NOTES:

120/208 VOLT, 3 PHASE, 4 WIRE											MOUNTED: SURFACE		
150A MCB EXISTING											KAIC: SEE FAULT ANALYSIS ON ONE LINE		
VA	Circuit	WIRE	TRIP AMPS	CCT	LINE A AMPS	LINE B AMPS	LINE C AMPS	CCT	TRIP AMPS	WIRE	Circuit	VA	
900	EXISTING			1	7.5	---			2		SPARE (EXISTING)	---	
150	EXISTING			3		1.3			4		SPARE (EXISTING)	---	
1440	EXISTING			5			12.0		6		SPARE (EXISTING)	---	
540	EXISTING			7	4.5	2.2			8		EXISTING	265	
360	EXISTING			9			3.0	5.3	10		EXISTING	632	
540	EXISTING			11			4.5	1.7	12		EXISTING	200	
1500	EXISTING			13	12.5	8.6			14	20	12	LTG - CUSTOMER SEATING	1030.5
1500	EXISTING			15		12.5	6.6		16	20	12	LTG - CUSTOMER SEATING	789
180	EXISTING			17			1.5	6.3	18	20	12	LTG - CUSTOMER SEATING	759
---	SPARE (EXISTING)			19	---	2.8			20	20	12	LTG - BAR AREA	339
---	SPARE (EXISTING)			21		---	12.0		22	20	12	WIREMOLD	1440
---	SPARE (EXISTING)			23			---	12.0	24	20	12	WIREMOLD	1440
---	SPARE (EXISTING)			25	---	9.0			26	20	12	CUSTOMER RECEP	1080
---	SPARE (EXISTING)			27		---	7.5		28	20	12	CUSTOMER RECEP	900
180	EXISTING			29			1.5	12.0	30	20	12	CUSTOMER RECEP	1440
---	SPARE (EXISTING)			31	---	3.0			32	20	12	REGISTER/POURSTEADY MACHINE	360
---	SPARE (EXISTING)			33		---	1.5		34	20	12	REGISTER	180
---	SPARE (EXISTING)			35		---	---		36			---	---
120	EXISTING			37	1.0	50.5			38		EXISTING	18200	
1000	EXISTING			39		8.3	50.5		40		---	---	
500	LIGHTING CONTROL PANEL	12	20	41			4.2	50.5	42		---	---	
		Total Amps:		102		108		106					

Load Classification	Connected Load	Demand Factors (%)	Estimated Demand	Panel Totals
Equipment	500	100%	500	Total Connected Load: 38 kVA
Kitchen	0	N/A	0	Total Estimated Demand Load: 45.6 kVA
Lighting	2918	125%	3646.875	Total Connected: 105 A
Receptacles	6840	100%	6840	Total Estimated Demand: 127 A
Existing Load	27707	125%	34633.75	

NOTES:

P:\Projects\01131011\025-000 Sunset Coffee Shop\E1800.dwg, 2:25:2016 6:16:48 PM, User: ARCH, Full: 02.10.16, 1:1

PANEL L3		120/208 VOLT, 3 PHASE, 4 WIRE										MOUNTED: SURFACE	
		400A MCB EXISTING										KAIC: 10K	
VA	Circuit	WIRE	TRIP AMPS	CCT	LINE A AMPS	LINE B AMPS	LINE C AMPS	CCT	TRIP AMPS	WIRE	Circuit	VA	
180	EXISTING		20	1	1.5	0.7			2	20	EXISTING	80	
180	EXISTING		20	3		1.5	---		4	20	SPARE (EXISTING)		
180	EXISTING		20	5				1.5	1.7	6	EXISTING	200	
360	EXISTING		20	7	3.0	---			8	20	SPARE (EXISTING)		
215	EXISTING		20	9		1.8	---		10	20	SPARE (EXISTING)		
2262	EXISTING		20	11				10.9	5.0	12	EXISTING	600	
---	SPARE		---	13	10.9	5.3			14	20	EXISTING	634	
---	SPARE		---	15			5.2		16	20	EXISTING	629	
---	SPARE		---	17			---	---	18	20	SPARE (EXISTING)		
1946	EXISTING		20	19	9.4	6.5			20	20	EXISTING	781	
---	SPARE		---	21			9.4	4.2	22	20	EXISTING	500	
4660	EXISTING		30	23			22.4	8.3	24	20	EXISTING	1000	
---	SPARE		---	25	22.4	---			26	20	SPARE (EXISTING)		
605	FCU-OA		12	20	27		2.9	8.3	28	20	EXISTING	1000	
---	SPARE		---	29			2.9	8.3	30	20	EXISTING	1000	
8426	EXISTING		12	---	31	40.5	8.3		32	20	EXISTING	1000	
---	SPARE		---	33			40.5	8.3	34	20	EXISTING	1000	
---	SPARE (EXISTING)		20	35			---	8.3	36	20	EXISTING	1000	
---	SPACE		---	37					38	20	SPARE (EXISTING)		
900	EXISTING		20	39			7.5	---	40	20	SPARE (EXISTING)		
500	FCU-2A		12	20	41			2.4	---	42	20	SPARE (EXISTING)	
---	SPARE		---	43	2.4	---			44	20	SPARE (EXISTING)		
500	FCU-2B		12	20	45			2.4	---	46	20	SPARE (EXISTING)	
---	SPARE		---	47			---	2.4	---	48	20	SPARE (EXISTING)	
180	MOTORIZED DAMPER		12	20	49	1.5	---		50		SPACE		
---	SPACE		---	51			---	---	52		SPACE		
---	SPACE		---	53			---	---	54		SPACE		
---	SPACE		---	55			---	---	56		SPACE		
---	SPACE		---	57			---	---	58		SPACE		
---	SPACE		---	59			---	---	60		SPACE		
---	SPACE		---	61			---	---	62		SPACE		
---	SPACE		---	63			---	---	64		SPACE		
---	SPACE		---	65			---	---	66		SPACE		
---	SPACE		---	67			---	---	68		SPACE		
---	SPACE		---	69			---	---	70		SPACE		
---	SPACE		---	71			---	---	72		SPACE		
---	SPACE		---	73			---	---	74		SPACE		
---	SPACE		---	75			---	---	76		SPACE		
---	SPACE		---	77			---	---	78		SPACE		
---	SPACE		---	79		143.5			80	225	PNL L2 (EXISTING)	51704	
---	SPACE		---	81			---	143.5	82		---	---	
---	SPACE		---	83			---	143.5	84		---	---	
Total Amps:					256	236	218						

Load Classification	Connected Load	Demand Factors (%)	Estimated Demand	Panel Totals
Equipment	1785	100%	1785	Total Connected Load: 82.2 kVA
Kitchen	0	N/A	0	Total Estimated Demand Load: 102.3 kVA
Lighting	0	N/A	0	Total Connected: 228 A
Receptacles	0	N/A	0	Total Estimated Demand: 284 A
Existing Load	80437	125%	100546.25	

NOTES:

LIGHT FIXTURE SCHEDULE					
TYPE	MFR	QTY-LAMP	VOLTS	MODEL #	DESCRIPTION
A	PHILIPS	3	120	8201BK/6001NBK/7683	TRACK LIGHT (3 HEADS)
A3	LURALINE	1	277	EXISTING	EXISTING COMPACT FLUORESCENT
B	PHILIPS	1	120	LSRXE1/LSR10827/L5RDD	RECESSED LED DOWNLIGHT
C	TECH	1	120	700TDSOCPVXXX / #300BHV480 / 700TDSWGX	PENDANT LIGHT
D	TECH	1	120	700TDSOCPVXXX / #300BHV480 / 700TDSWGX	PENDANT LIGHT
E	TECH	1	120	700WSCFTZ	WALL SCONCE
F	CHLOR	1	120/277	CALIBER SERIES	
H	CWL	6	120	LIGHTING NEW YORK - S 5015AI	LINEAR PENDANT
J	PHILIPS	3	120	8201BK / 6001NBK / 6099BK / PLD240BK / 7683	TRACK LIGHT (3 HEADS)
K	PHILIPS	1	120	700MPROTXS	PENDANT ADJUSTABLE MONOPOINT
L	PHILIPS	2	120	8201BK / 6001NBK / 6099BK / PLD240BK / 7683	TRACK LIGHT (2 HEADS)
P1-D	LURALINE	1	120/277	EXISTING	EXISTING COMPACT FLUORESCENT
X	COOPER	2	277	AEL2-31-XX-SD	ARCHITECTURAL LED EMERGENCY LIGHT

GENERAL NOTES

A. CONTRACTOR TO FIELD VERIFY NUMBER AND LOCATION OF EXISTING SPARES.

KEY NOTES



BRAVE / ARCHITECTURE

4617 Montrose Blvd., Suite C.230
Houston, Texas 77006
Voice: 713.524.5858
Fax: 713.524.5868
studio@bravearchitecture.com
Contact: Silvana Micolich
smicolich@bravearchitecture.com

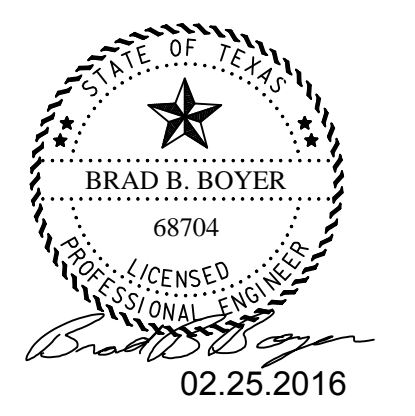

Consultants:

MEP:

Collaborative Engineering Group
8904 Fairbanks N. Houston Suite 201
Houston, TX 77064
T: 281.598.1170
F: 281.598.1130

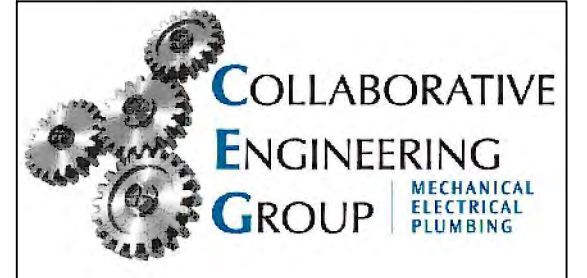

8904 Fairbanks N. Houston, Suite 201
Houston, Texas 77064
281.598.1170
www.collaborative-engr.com
Firm No. F12678

SUNSET COFFEE

1019 Commerce St.
Houston, TX 77002

Ownership of Instruments of Service:
All reports, plans, specifications, computer files, field data, notes & other documents and instruments prepared by BRAVE / ARCHITECTURE as instruments of service shall remain the property of BRAVE / ARCHITECTURE. BRAVE / ARCHITECTURE shall retain all common law, statutory and other reserved rights, including the copyright thereto.

ISSUE:
ISSUE FOR PERMIT 02.25.2016

B/A Project No.: 15137
Drawn By: TLK
Checked By: BBB
Date:
Scale: AS NOTED

ELECTRICAL SCHEDULES

P:\Projects\01152015\025-000 Sunset Coffee Shop\E1800.dwg, 2/25/2016 6:16:50 PM, User: ARCH, Full Name: D:\A100\T\36100 (Inches), 1:1



BRAVE / ARCHITECTURE

4617 Montrose Blvd., Suite C.230
Houston, Texas 77006
Voice: 713.524.5858
Fax: 713.524.5868
studio@bravearchitecture.com
Contact: Silvana Micolich
smicolich@bravearchitecture.com

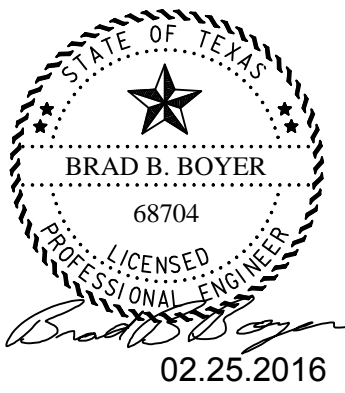

Consultants:

MEP:

Collaborative Engineering Group
8904 Fairbanks N. Houston Suite 201
Houston, TX 77064
T: 281.598.1170
F: 281.598.1130

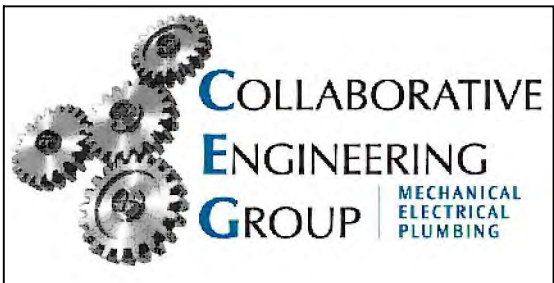

8904 Fairbanks N. Houston, Suite 201
Houston, Texas 77064
281.598.1170
www.collaborative-engr.com
Firm No. F12678

SUNSET COFFEE

1019 Commerce St.
Houston, TX 77002

Ownership of Instruments of Service:
All reports, plans, specifications, computer files, field data, notes & other documents and instruments prepared by BRAVE / ARCHITECTURE as instruments of service shall remain the property of BRAVE / ARCHITECTURE. BRAVE / ARCHITECTURE shall retain all common law, statutory and other reserved rights, including the copyright thereto.

ISSUE:
ISSUE FOR PERMIT 02.25.2016

B/A Project No.: 15137
Drawn By: TLK
Checked By: BBB
Date:
Scale: AS NOTED

ELECTRICAL DETAILS

E9.00

GENERAL NOTES

KEY NOTES

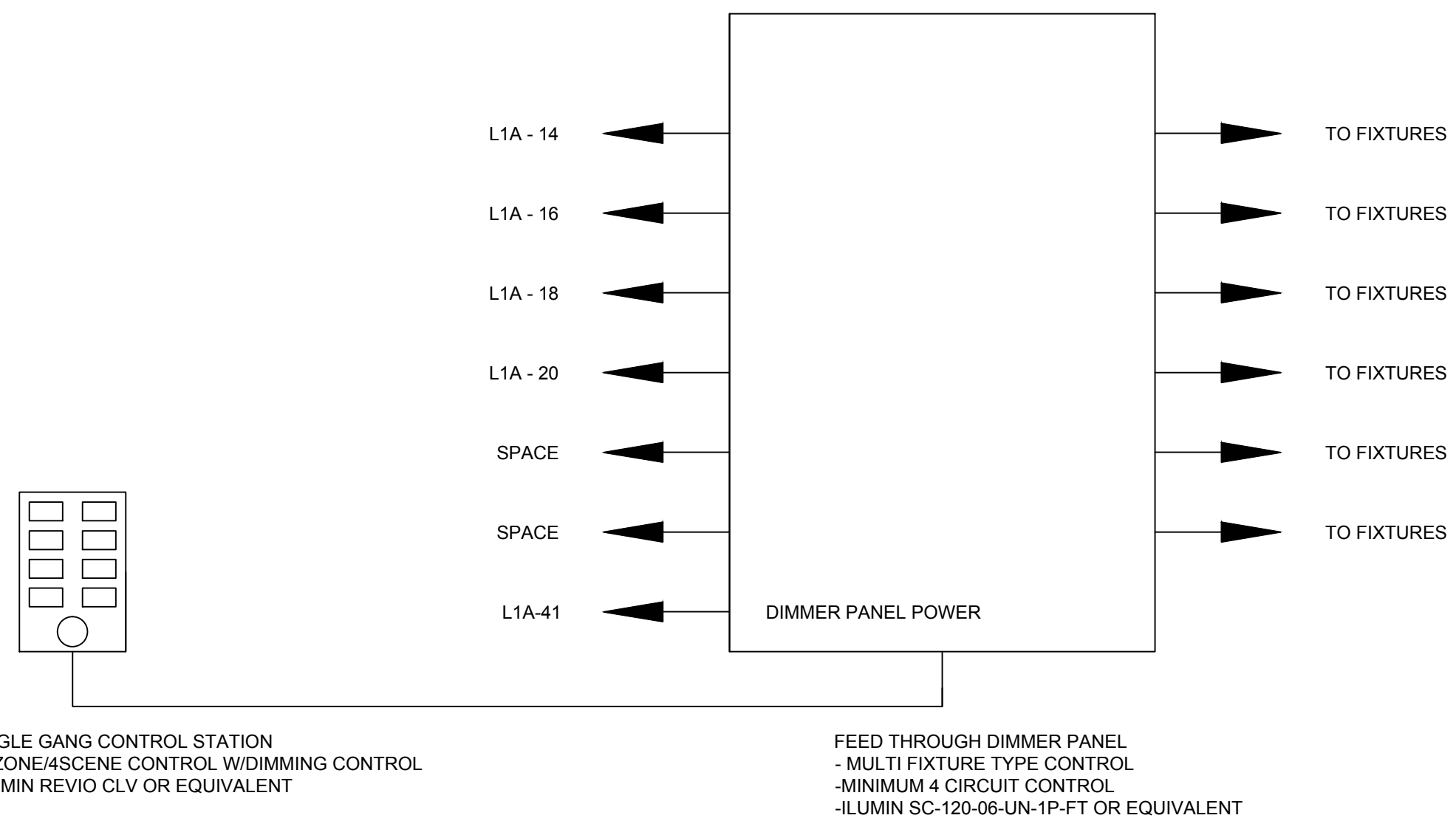

P:\Projects\01152015\025-000 Sunset Coffee Shop\E 1506.dwg, 2:25:2016 6:16:32 PM, User: ARCH, Full: 02.10.16 11:36:00 (mch), 1:1

PLUMBING GENERAL NOTES:

A. DRAWINGS ARE DIAGRAMATIC ONLY AND REPRESENT THE GENERAL SCOPE OF THE WORK. PRIOR TO SUBMITTING BID, PLUMBING CONTRACTOR (PC) AND HIS SUBCONTRACTORS SHALL VISIT THE JOB SITE AND FULLY ACQUAINT HIMSELF WITH THE EXISTING CONDITIONS OF THE PROJECT. THE CONTRACTOR AND HIS SUBCONTRACTORS SHALL BE RESPONSIBLE FOR REVIEW OF GENERAL NOTES, SPECIFICATIONS AND ALL OTHER PLANS FOR ADDITIONAL REQUIREMENTS WHICH MAY NOT BE SPECIFICALLY CALLED OUT IN THIS PORTION OF THE CONSTRUCTION DOCUMENTS. NOTIFY OWNER'S CONSTRUCTION MANAGER OF ANY CONFLICTS OR DISCREPANCIES PRIOR TO SUBMISSION OF BID.

B. PC IS RESPONSIBLE FOR THE INSTALLATION TO COMPLY WITH, AND BE INSTALLED IN ACCORDANCE WITH ALL LEGALLY CONSTITUTED AUTHORITIES AND CODES HAVING JURISDICTION AND ALSO MEET ALL REQUIREMENTS OF THE LANDLORD.

C. PLANS AND SPECIFICATIONS GOVERN WHERE THEY EXCEED CODE REQUIREMENTS.

D. PC SHALL VERIFY LOCATION AND DEPTH OF UTILITIES AT POINTS OF CONNECTION BEFORE START OF PROJECT.

E. REFER TO ARCHITECTURAL PLANS FOR EXACT LOCATION OF PLUMBING FIXTURES.

DO NOT SCALE FLOOR PLANS FOR EXACT HORIZONTAL LOCATION OF PIPE ROUTING.

VALVES SHALL BE LINE SIZE UNLESS OTHERWISE NOTED.

ALL PIPING IN FINISHED AREAS SHALL BE ROUTED CONCEALED; EXPOSED PIPING, WHERE NECESSARY, SHALL BE ROUTED AS HIGH AS POSSIBLE AND TIGHT TO WALLS.

COORDINATE WITH ARCHITECT, LANDLORD AND OWNER, PLASTIC PIPE MAY BE ALLOWED UNDERSLAB ONLY. NO PLASTIC PIPE SHALL BE INSTALLED IN THE CEILING RETURN AIR PLENUM.

COORDINATE ALL WORK WITH OTHER TRADES AND CONTRACTORS.

PC SHALL COORDINATE ALL PLUMBING PIPING INSTALLATION WITH STRUCTURAL GRADE BEAMS, FOOTINGS, COLUMNS PIERS, ETC. SLEEVE PIPING THROUGH GRADE BEAMS, FOOTING, ETC. WHERE REQUIRED AND AS NOTED ON PLANS. COORDINATE SLEEVE INSTALLATIONS WITH THE ARCHITECT, STRUCTURAL ENGINEER, STRUCTURAL CONTRACTOR AND GENERAL CONTRACTOR BEFORE CONCRETE IS PLACED.

CLEAN FAUCET AERATORS AND PIPE STRAINERS PRIOR TO TURNING BUILDING OVER TO THE OWNER.

PROVIDE TRAP PRIMERS WHERE REQUIRED BY LOCAL AUTHORITIES.

COORDINATE PIPE ROUTING AWAY FROM ELECTRICAL PANELS. DO NOT ROUTE PIPING OVER ELECTRICAL PANELS.

PAINT ALL EXPOSED GAS AND WATER PIPING USING RUST INHIBITOR PAINT, RUSTOLEUM OR EQUAL. COLOR SHALL BE COORDINATED WITH THE ARCHITECT AND/OR OWNER.

KITCHEN GENERAL NOTES

PLUMBING CONTRACTOR (PC) SHALL INSTALL ANY DEVICES FURNISHED BY KITCHEN EQUIPMENT CONTRACTOR (KEC). SEE THE KITCHEN EQUIPMENT DRAWINGS FOR ITEMS TO BE PROVIDED BY THE PC. PC SHALL PROVIDE ITEMS AND WORK AS REQUIRED TO COMPLETE THE INSTALLATION OF PLUMBING SYSTEMS OF KITCHEN ITEMS.

PC SHALL BE RESPONSIBLE FOR ALL PLUMBING CONNECTIONS TO KITCHEN EQUIPMENT. COORDINATE PLUMBING ROUGH-IN AND CONNECTION REQUIREMENTS WITH THE KEC PRIOR TO START OF ROUGH-IN WORK.

PROVIDE ITEMS AND WORK AS REQUIRED TO COMPLETE THE INSTALLATION OF THE PLUMBING SYSTEMS TO FIXTURES AND EQUIPMENT: TRAPS, PIPE TO THE WALL, ESCUTCHEONS, ETC. PROVIDE AND CONNECT PLUMBING PIPE FROM ROUGH-INS TO ITEMS SHOWN, SPECIFIED AND REQUIRED.

PC SHALL PROVIDE SHUTOFF VALVE OR ANGLE STOP VALVE ON EACH WATER CONNECTION TO KEC EQUIPMENT. PROVIDE AND CONNECT PLUMBING PIPE FROM ROUGH-IN TO ITEMS AS SHOWN, SPECIFIED OR REQUIRED. WHERE "FLEX" TUBING IS CALLED FOR, PROVIDE A FOUR FOOT COILED LENGTH OF TYPE "K" SOFT COPPER TUBING FROM WATER SHUT-OFF VALVE TO THE EQUIPMENT CONNECTION OF SAME SIZE AS CONNECTION TO EQUIPMENT WITH 1/4" IN BEING MINIMUM SIZE. PROVIDE CONNECTORS AND ADAPTERS AS REQUIRED.

INSTALL INDIRECT WASTE LINES OF SAME SIZE AS CONNECTION TO EQUIPMENT WITH 3/4" BEING MINIMUM SIZE. ROUTE FROM EQUIPMENT CONNECTION POINTS INDICATED ON THE KEC DRAWINGS TO FLOOR DRAIN OR FLOOR SINK. PROVIDE AIR GAP OF TWO PIPE SIZES MINIMUM AS REQUIRED BY CODE.

COMPLY WITH HEALTH DEPARTMENT REGULATIONS. PROVIDE CLEARANCE FOR CLEANING BEHIND AND UNDER EXPOSED PIPING AS REQUIRED BY HEALTH DEPARTMENT. CONFORM TO HEALTH DEPARTMENT REQUIREMENTS FOR LOCATIONS OF FLOOR SINKS.

COORDINATE FLOOR DRAIN LOCATION AND FLOOR SLOPE REQUIREMENTS WITH THE ARCHITECT. RIM OF FLOOR DRAINS AND FLOOR SINKS SHALL BE LOCATED BELOW FINISHED FLOOR LEVEL. SLOPE FLOOR TO DRAINS. REFER TO ARCHITECTURAL DRAWINGS.

COORDINATE LOCATION OF VENT, WATER, AND GAS PIPING TO AVOID CONFLICT WITH OTHER TRADES.

PC SHALL PROVIDE FINAL CLEANING OF FIXTURES AND EQUIPMENT INSTALLED BY PC.

PC SHALL PROVIDE WALL BACKING OR SPECIFIED CARRIERS FOR THE PROPER SUPPORT OF ALL WALL HUNG FIXTURES AND EQUIPMENT.

PC SHALL CAULK AROUND FIXTURES AND EQUIPMENT INSTALLED BY THE PC AND THE KEC.

PC SHALL PROVIDE APPROPRIATE BACKFLOW PREVENTION DEVICES FOR EQUIPMENT REQUIRING THEM PER LOCAL AUTHORITIES REQUIREMENTS. PC SHALL INSTALL BACKFLOW PREVENTION DEVICES PROVIDED WITH EQUIPMENT PROVIDED BY KEC.

	PLUMBING FIXTURE SCHEDULE
	FIXTURES IN THIS SCHEDULE OR THEIR APPROVED EQUIVALENT ARE PROVIDED BY THE PLUMBING CONTRACTOR. SUBMIT SHOP DRAWINGS ON EACH OF THESE ITEMS. REFER TO SPECIFICATIONS FOR FURTHER INFORMATION AND INSTALLATION REQUIREMENTS. VERIFY ROUGH-IN REQUIREMENTS WITH MANUFACTURER'S INSTALLATION INSTRUCTIONS AND INSTALL PER MANUFACTURER'S RECOMMENDATIONS. REFER TO THE ARCHITECTURAL DRAWINGS FOR THE PLUMBING FIXTURE MOUNTING HEIGHTS.
(FCO)	FLOOR CLEANOUT: JAY R. SMITH, CAST IRON BODY, FLASHING FLANGE WITH CLAMPING COLLAR, ABS PLUG, AND ADJUSTABLE, SQUARE, SECURED, NICKEL BRONZE, TOP. # 4051L (-F-C), SCORRIATED TOP FOR EXPOSED, FLUSH WITH FINISHED FLOOR, APPLICATION(S), # 4171 (-F-C), 1/8" RECESS FOR INSTALLATION IN TILED FLOOR AREA(S), # 4211 (-F-C), 1/2" RECESS FOR INSTALLATION IN TERRAZZO AND SIMILAR POURED FLOOR AREA(S). REFER TO SPECIFICATIONS FOR INSTALLATION.
(FS-1)	FLOOR SINK: JAY R. SMITH # 3041C (-12), 6" DEEP CAST IRON BODY WITH ACID RESISTING ENAMELED INTERIOR, ANCHOR FLANGE WITH SEEPAGE HOLES, CLAMP COLLAR, ALUMINUM SEDIMENT BUCKET, AND 8-1/2" ROUND NICKEL BRONZE RIM AND HALF GRATE. USE CAULK JOINT OF OUTLET SIZE AS SHOWN ON PLANS.
(SK-1)	SINK: ADVANCE TABCO MODEL DI-1-25, 20 GAUGE TYPE 304 STAINLESS STEEL, FIXTURE WITH FAUCET LEDGE. SET IN BED OF PUTTY. FAUCET: ADVANCE TABCO K-52 GOOSENECK FAUCET, 4" O.C. TRIM: MCGUIRE # LF2165CC LEAD FREE BRASS WHEEL HANDLE ANGLE STOP VALVES WITH RISERS AND ESCUTCHEONS, MCGUIRE # 151M CUP STRAINER WITH 1-1/2" 17 GAUGE TAILPIECE, MCGUIRE # B8912CF 1-1/2" 17 GAUGE CAST CHROME PLATED BRASS ADJUSTABLE P-TRAP WITH BRASS CLEANOUT AND ESCUTCHEON.
(SK-2)	SINK: ADVANCE TABCO MODEL DI-1-2012, 20 GAUGE TYPE 304 STAINLESS STEEL, FIXTURE WITH FAUCET LEDGE. SET IN BED OF PUTTY. FAUCET: ADVANCE TABCO K-50 FAUCET, 4" O.C. TRIM: MCGUIRE # LF2165CC LEAD FREE BRASS WHEEL HANDLE ANGLE STOP VALVES WITH RISERS AND ESCUTCHEONS, MCGUIRE # 151M CUP STRAINER WITH 1-1/2" 17 GAUGE TAILPIECE, MCGUIRE # B8912CF 1-1/2" 17 GAUGE CAST CHROME PLATED BRASS ADJUSTABLE P-TRAP WITH BRASS CLEANOUT AND ESCUTCHEON.
(SK-3)	SINK: EAGLE GROUP HAND SINK MODEL HSA-10-FDP, 304 STAINLESS STEEL SINGLE BOWL WITH P-TRAP, TAIL PIECE, FRONT SKIRT. WITH SOAP DISPENSER, FAUCET AND BASKET DRAIN.
(IMB)	ICE MAKER BOX: GUY GRAY MODEL # BIM875, 20 GAUGE GALVANIZED STEEL BOX, 18 GAUGE STEEL FACEPLATE, BOTTOM INLET WATER SUPPLY WITH 1/2" x 1/4" COMPRESSION ANGLE STOP VALVE. TRIM: LOOP 4 FEET OF 1/4" TYPE "K" SOFT COPPER TUBING.
(DCV)	DOUBLE CHECK VALVE. WATTS # 9BD, MEETING NSF 25, 316 STAINLESS STEEL BODY, 3/8" INLET AND OUTLET.
(WHA)	WATER HAMMER ARRESTER: PRECISION PLUMBING PRODUCTS, HARD DRAWN COPPER BODY WITH WROUGHT COPPER FITTINGS, PISTON TYPE WITH LUBRICATED EPDM "O" RING SEALS, MEETING ASSE 1010 OR PDI WH-201. PROVIDE PDI SIZES "A" THROUGH "F" AS SHOWN ON PLANS. PROVIDE SIZE "A" UNLESS SHOWN OTHERWISE ON THE PLANS.
(WCO)	WALL CLEANOUT: SIOUX CHIEF #873 SERIES, BRASS COUNTERSUNK PLUG, 20 GAUGE STAINLESS STEEL COVER AND SCREW. CLEANOUT TEE TO BE PROVIDED SEPARATELY. REFER TO SPECIFICATIONS FOR INSTALLATION.
(TMV)	THERMOSTATIC MIXING VALVE: POWERS # Lfe480, SOLID LEAD FREE BRASS BODY, THERMOSTATIC WAX ELEMENT, CORROSION RESISTANT INTERNAL PARTS, AND INTEGRAL CHECKS, ASSE 1070 COMPLIANT, CAPABLE OF 2.2 GPM WITH A 20 PSI DIFFERENTIAL AND A MINIMUM FLOW RATE OF 0.5 GPM. SET TEMPERATURE TO 110F FOR HAND SINKS. MOUNT BELOW THE PLUMBING FIXTURE WHERE INDICATED ON PLANS(S).

PLUMBING GENERAL NOTES:

- CODE REQUIREMENTS: ALL WORK PERFORMED SHALL BE IN STRICT ACCORDANCE WITH ALL LOCAL, STATE, AND FEDERAL LAWS, RULES, ORDINANCES, REGULATIONS, ETC, AS WELL AS ALL CODES AND REQUIREMENTS. THE CONTRACTOR SHALL BE HELD FULLY RESPONSIBLE FOR THE PROPER INSTALLATION OF THIS WORK UNDER THE ABOVE REGULATIONS AND SHALL PERFORM AT HIS OWN EXPENSE ALL WORK NECESSARY TO MEET SUCH REQUIREMENTS WHETHER OR NOT SUCH WORK IS SHOWN ON THE DRAWINGS.
- PERMITS AND FEES: THE CONTRACTOR SHALL OBTAIN ALL NECESSARY PERMITS AND INSPECTIONS REQUIRED FOR THE INSTALLATION OF WORK AND PAY ALL CHARGES INCIDENTAL THERETO.
- TESTS: CONTRACTOR SHALL BE RESPONSIBLE FOR PERFORMING ALL TESTS NECESSARY TO PREVENT CONCEALMENT OF DEFECTIVE OR IMPROPER WORK. UPON COMPLETION OF WORK, TEST INSTALLATION THOROUGHLY AND RENDER IT FROM LEAKS OR IMPROPER CONNECTIONS.
- PROTECT EQUIPMENT AND WORK FROM DAMAGE DURING HANDLING AND INSTALLATION UNTIL COMPLETION OF CONSTRUCTION. REMOVE ALL EXCESS MATERIAL AND DEBRIS AND CLEAN ALL EQUIPMENT UPON COMPLETION OF WORK. TOUCH UP WITH PAINT WHERE REQUIRED.
- REFER TO ELECTRICAL DRAWINGS FOR ELECTRICAL CHARACTERISTICS OF ALL EQUIPMENT. PLUMBING CONTRACTOR SHALL COORDINATE WITH ELECTRICAL CONTRACTOR PRIOR TO ORDERING AND INSTALLING PLUMBING EQUIPMENT.
- PLUMBING CONTRACTOR SHALL COORDINATE PIPING AND EQUIPMENT WITH ALL OTHER TRADES PRIOR TO INSTALLATION OF ANY PIPING, OR EQUIPMENT.
- DO NOT SCALE FROM THE ENGINEERED DRAWINGS. REFER TO THE DIMENSIONED DRAWINGS OF THE ARCHITECT FOR EXACT LOCATIONS OF FIXTURES, EQUIPMENT, ETC.
- PROSET TRAP GUARD SHALL BE INSTALLED ON ALL FLOOR DRAINS AND FLOOR SINKS.
- COORDINATE ALL FLOOR DRAINS AND FLOOR SINKS SHOWN IN THE MECHANICAL ROOMS AND EQUIPMENT ROOMS WITH ALL OTHER TRADES PRIOR TO INSTALLATION.
- ALL CONNECTIONS BETWEEN PIPES OF DISSIMILAR MATERIALS SHALL BE MADE WITH DIELECTRIC UNIONS.
- EACH WATER SUPPLIED FIXTURE AND PIECE OF EQUIPMENT SHALL BE PROVIDED WITH ITS OWN INDIVIDUAL AND ACCESSIBLE SHUT-OFF/STOP VALVE.

PIPING INSULATION SCHEDULE		
SYSTEM	PIPE SIZES	MATERIAL
DOMESTIC HOT WATER	ALL	MINERAL FIBER, PREFORMED, TYPE I, 1" THICK FOR 1 1/4" AND BELOW, 2" THICK FOR 1 1/2" AND ABOVE
DOMESTIC COLD WATER (IN EXTERIOR WALLS AND ATTIC)	ALL	MINERAL FIBER, PREFORMED, TYPE I, 1" THICK
FLOOR DRAINS, TRAPS, AND SANITARY DRAIN PIPING WITHIN 10 FT OF DRAIN RECEIVING CONDENSATE BELOW 60°F	ALL	MINERAL FIBER, PREFORMED, TYPE I, 1/2" THICK
NOTES:		
1. PROVIDE ALUMINUM JACKET ON EXPOSED INSULATED PIPING. REFER TO SPECIFICATIONS.		
2. REFER TO SPECIFICATIONS FOR ADDITIONAL INFORMATION.		

PLUMBING FIXTURE CONNECTIONS						
FIXTURE	DESCRIPTION	WASTE	VENT	COLD WATER	HOT WATER	
SK-1	SINK, SINGLE COMPARTMENT	2"	2"	1/2"	1/2"	
FS-1	FLOOR SINK	PER PLANS	2"	--	--	
FCO	FLOOR CLEANOUT	PER PLANS	--	--	--	

PIPING MATERIAL SCHEDULE	
SYSTEM	MATERIAL
SANITARY WASTE/VENT ABOVE GRADE, INSIDE BLDG	CAST IRON PIPE AND FITTINGS WITH HUB OR NO-HUB JOINTS OR SCHEDULE 40 PVC PIPE AND FITTINGS
DOMESTIC WATER ABOVE GRADE, INSIDE BLDG	TYPE "L" COPPER WITH SOLDER-JOINT FITTINGS
FIRE SPRINKLER	BLACK STEEL PIPE AND FITTINGS
NOTES:	
1. REFER TO SPECIFICATIONS FOR ADDITIONAL INFORMATION AND OPTIONS.	
2. PVC NOT TO BE USED IN RETURN AIR PLENUM.	

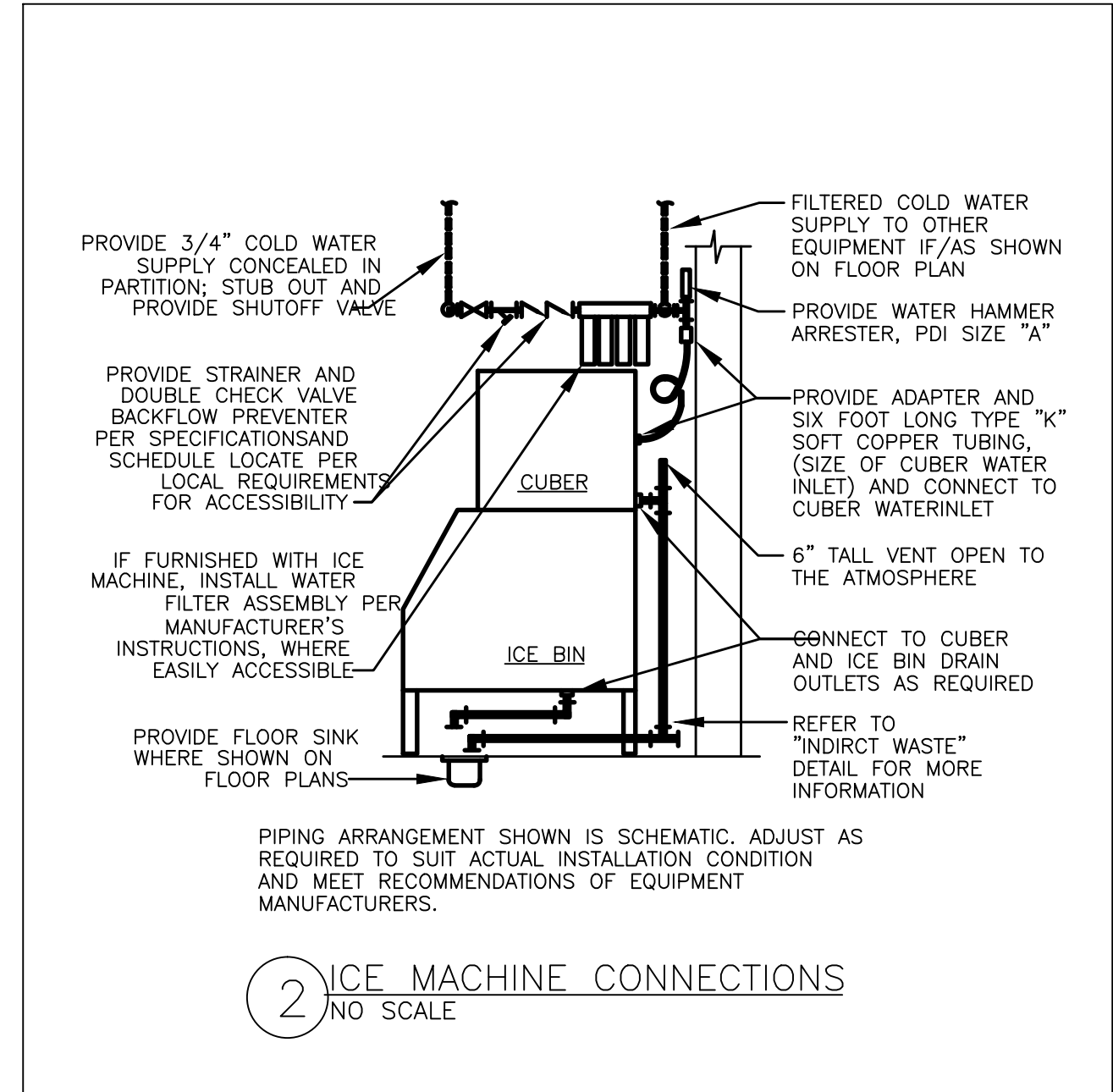
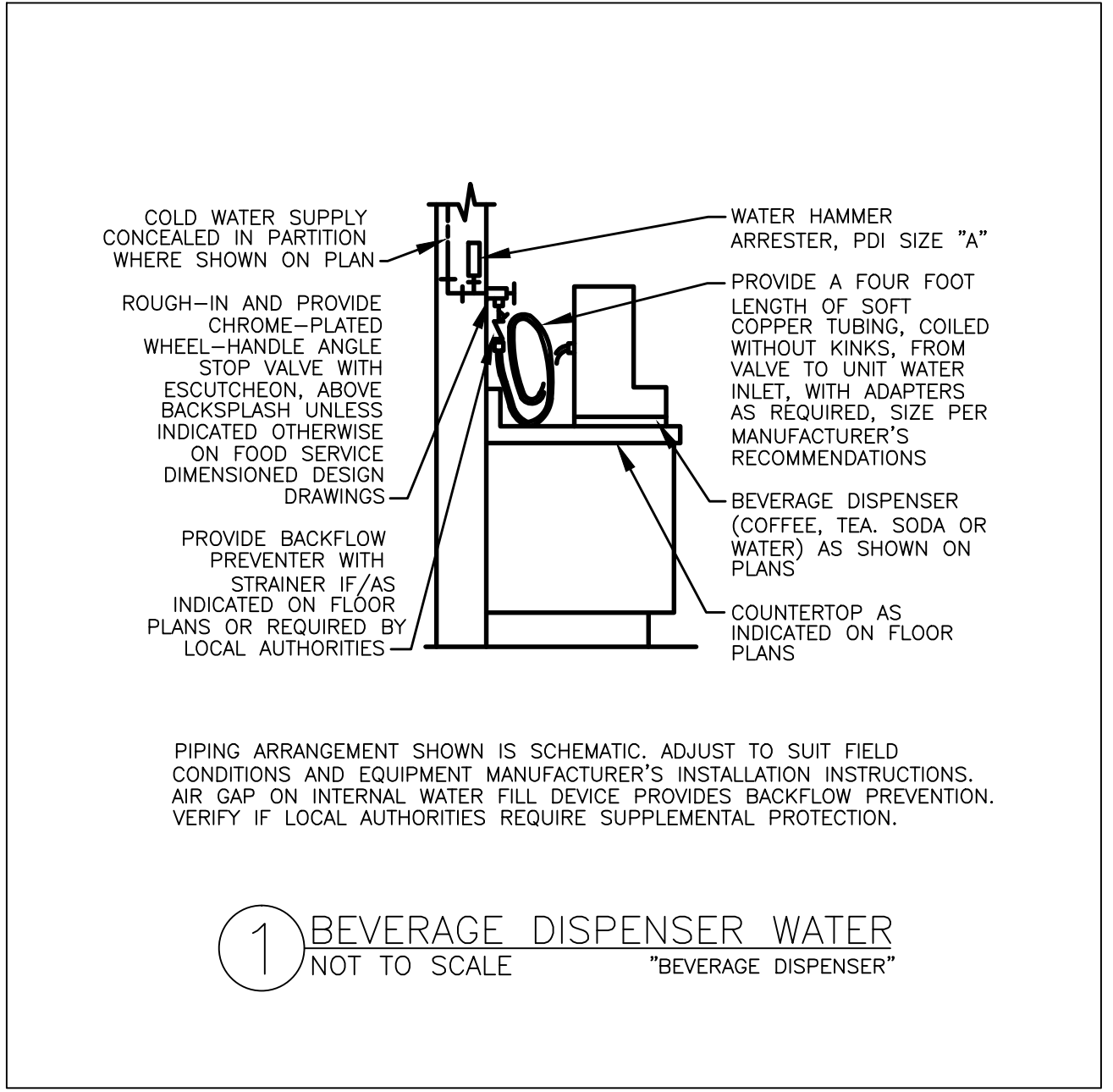

DIVISION 22 - PLUMBING

220000 PLUMBING BASIC REQUIREMENTS

A. MINIMUM STANDARDS FOR ALL WORK SHALL BE 2009 INTERNATIONAL BUILDING CODE, 2009 INTERNATIONAL PLUMBING CODE, AND 2009 INTERNATIONAL ENERGY CONSERVATION CODE.

B. THE PLUMBING SYSTEMS SHALL INCLUDE DOMESTIC COLD WATER, DOMESTIC HOT WATER, SANITARY AND WASTE AND VENT. EXTEND ALL UTILITIES TO 5'-0" OUTSIDE OF THE BUILDING. EXTENSION OF UTILITIES TO MAINS SHALL BE PROVIDED UNDER ANOTHER DIVISION (CIVIL).

C. REFERENCES: THE STANDARDS MENTIONED HEREIN WILL BE REFERRED TO IN THE DESIGN OF PLUMBING SYSTEMS. THE ENGINEER WILL SELECT APPROPRIATE SECTIONS OF THE STANDARD TO BE APPLIED IN ACCORDANCE WITH ESTABLISHED ENGINEERING PRINCIPLES AND PRACTICES.

1. APPLICABLE SECTIONS OF NFPA
2. AMERICANS WITH DISABILITIES ACT (ADA)
3. TEXAS ACCESSIBILITY STANDARDS (TAS)

D. SITE CONDITIONS: BEFORE SUBMITTING ANY PROPOSAL, EXAMINE THE PROPOSED SITE AND DETERMINE ANY CONDITIONS THAT MAY AFFECT THE WORK. NO ALLOWANCE SHALL BE MADE FOR FAILURE TO MAKE SURE EXAMINATIONS.

E. THE CONTRACTOR IS RESPONSIBLE FOR ALL WORK, MATERIALS, AND LABOR TO SATISFY A COMPLETE WORKING SYSTEM WHETHER SPECIFIED OR IMPLIED.

F. THE CONTRACTOR IS RESPONSIBLE FOR COORDINATING WITH ALL OTHER TRADES INCLUDING ARCHITECT, STRUCTURAL, CIVIL, MECHANICAL, AND ELECTRICAL.

G. DO NOT SCALE FROM THE ENGINEERED DRAWINGS. REFER TO THE DIMENSIONED DRAWINGS OF THE ARCHITECT FOR EXACT LOCATIONS OF FIXTURES, EQUIPMENT, ETC.

H. THE CONTRACTOR SHALL OBTAIN ALL NECESSARY PERMITS AND INSPECTIONS REQUIRED FOR THE INSTALLATION OF WORK AND PAY ALL INCIDENTAL CHARGES.

I. THE CONTRACTOR SHALL BE RESPONSIBLE FOR PERFORMING ALL TESTS NECESSARY TO PREVENT CONCEALMENT OF DEFECTIVE OR IMPROPER WORK. UPON COMPLETION OF WORK, TEST INSTALLATION THOROUGHLY AND RENDER IT FROM LEAKS OR IMPROPER CONNECTIONS.

J. PROTECT EQUIPMENT AND WORK FROM DAMAGE DURING HANDLING AND INSTALLATION UNTIL COMPLETION OF CONSTRUCTION. REMOVE ALL EXCESS DEBRIS AND CLEAN ALL EQUIPMENT UPON COMPLETION OF WORK. TOUCH UP WITH PAINT WHERE REQUIRED.

220719 PLUMBING PIPING INSULATION

A. REFER TO SCHEDULE.

221116 DOMESTIC WATER PIPING

A. REFER TO SCHEDULE FOR PIPE MATERIAL.
B. PROVIDE SHUT-OFF VALVE AT EACH MAJOR BRANCH LINE.
C. EACH WATER SUPPLIED FIXTURE AND PIECE OF EQUIPMENT SHALL BE PROVIDED WITH ITS OWN INDIVIDUAL AND ACCESSIBLE SHUT-OFF/STOP VALVE.
D. INSTALL DIELECTRIC FITTINGS IN PIPING AT CONNECTIONS OF DISSIMILAR METAL PIPING AND TUBING.

221316 SANITARY WASTE AND VENT SYSTEM

A. REFER TO SCHEDULE.

221319 SANITARY WASTE PIPING SPECIALTIES

A. INSTALL CLEANOUTS IN ABOVE GROUND PIPING AND BUILDING DRAIN PIPING ACCORDING TO THE FOLLOWING UNLESS OTHERWISE NOTED:
1. SIZE SAME AS DRAINAGE PIPING UP TO 4". USE 4" FOR LARGER DRAINAGE PIPING UNLESS LARGER CLEANOUT IS INDICATED.
2. LOCATE AT EACH CHANGE IN DIRECTION OF PIPING GREATER THAN 45 DEGREES.
3. LOCATE AT MINIMUM OF 50 FEET FOR PIPING 4" AND SMALLER AND 90 FEET FOR LARGER PIPING.
C. FOR FLOOR CLEANOUTS IN PIPING BELOW FLOORS, INSTALL CLEANOUT DECK PLATES WITH TOP FLUSH WITH FINISHED FLOOR.

BRAVE / ARCHITECTURE

4617 Montrose Blvd., Suite C.230
Houston, Texas 77006
Voice: 713.524.5858
Fax: 713.524.5868
studio@bravearchitecture.com
Contact: Silvana Micolich
smicolich@bravearchitecture.com



Consultants:

MEP:

Collaborative Engineering Group
8904 Fairbanks N. Houston Suite 201
Houston, TX 77064
T: 281.598.1170
F: 281.598.1130

COLLABORATIVE ENGINEERING GROUP MECHANICAL ELECTRICAL PLUMBING

8904 Fairbanks N. Houston, Suite 201
Houston, Texas 77064
281.598.1170
www.collaborative-engr.com
Firm No. F12678

SUNSET COFFEE

1019 Commerce St.
Houston, TX 77002

Ownership of Instruments of Service:
All reports, plans, specifications, computer files, field data, notes & other documents and instruments prepared by BRAVE / ARCHITECTURE as instruments of service shall remain the property of BRAVE / ARCHITECTURE. BRAVE / ARCHITECTURE shall retain all common law, statutory and other reserved rights, including the copyright thereto.

ISSUE:
ISSUE FOR PERMIT 02.25.2016
PERMIT RESPONSES 04.28.2016

B/A Project No.: 15137
Drawn By: XX
Checked By: XX
Date:
Scale: AS NOTED

PLUMBING SYMBOLS & ABBREVIATIONS

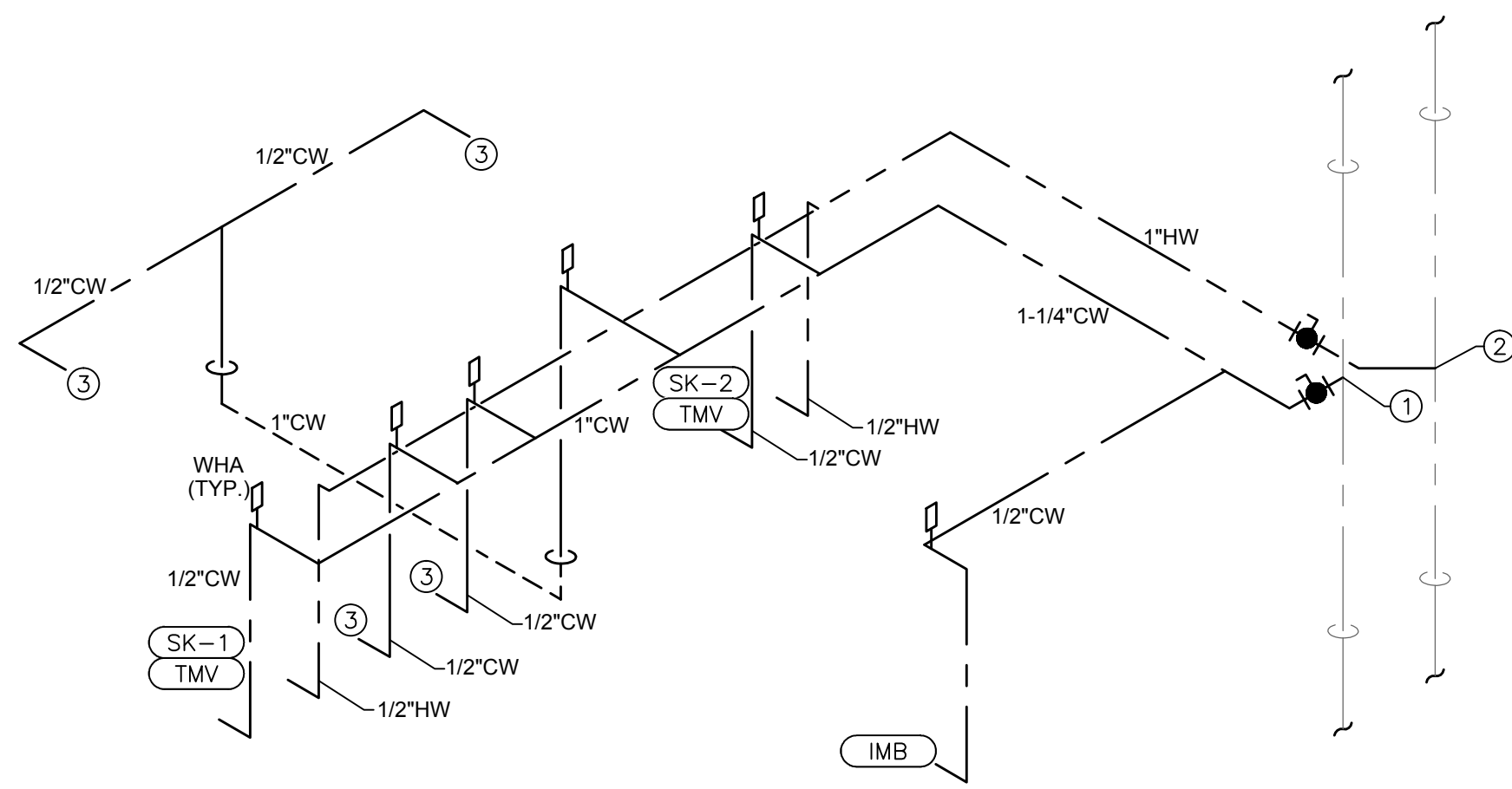

PLUMBING DOMESTIC WATER RISER DIAGRAM

NOT TO SCALE 1

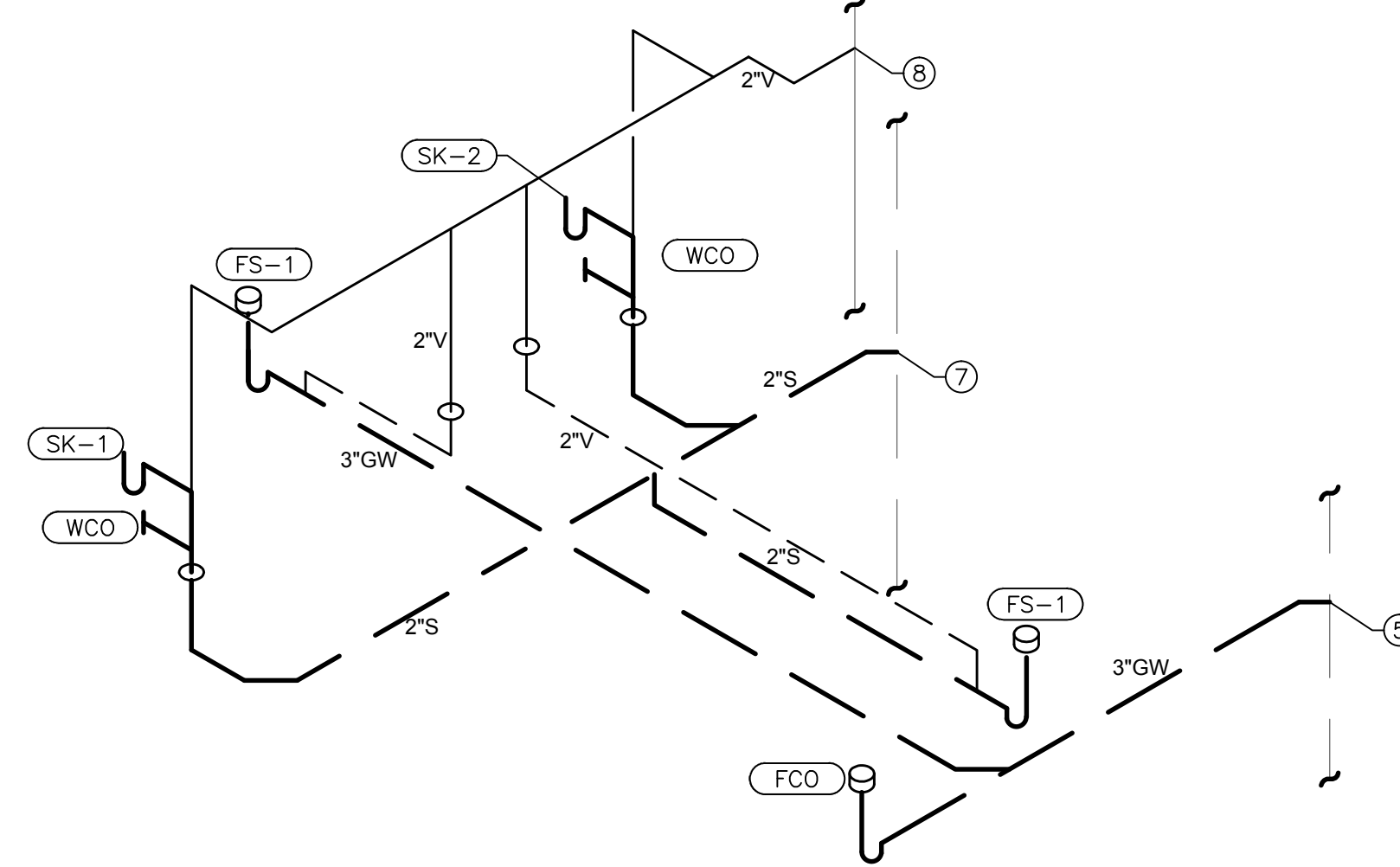

PLUMBING SANITARY RISER DIAGRAM

NOT TO SCALE 2

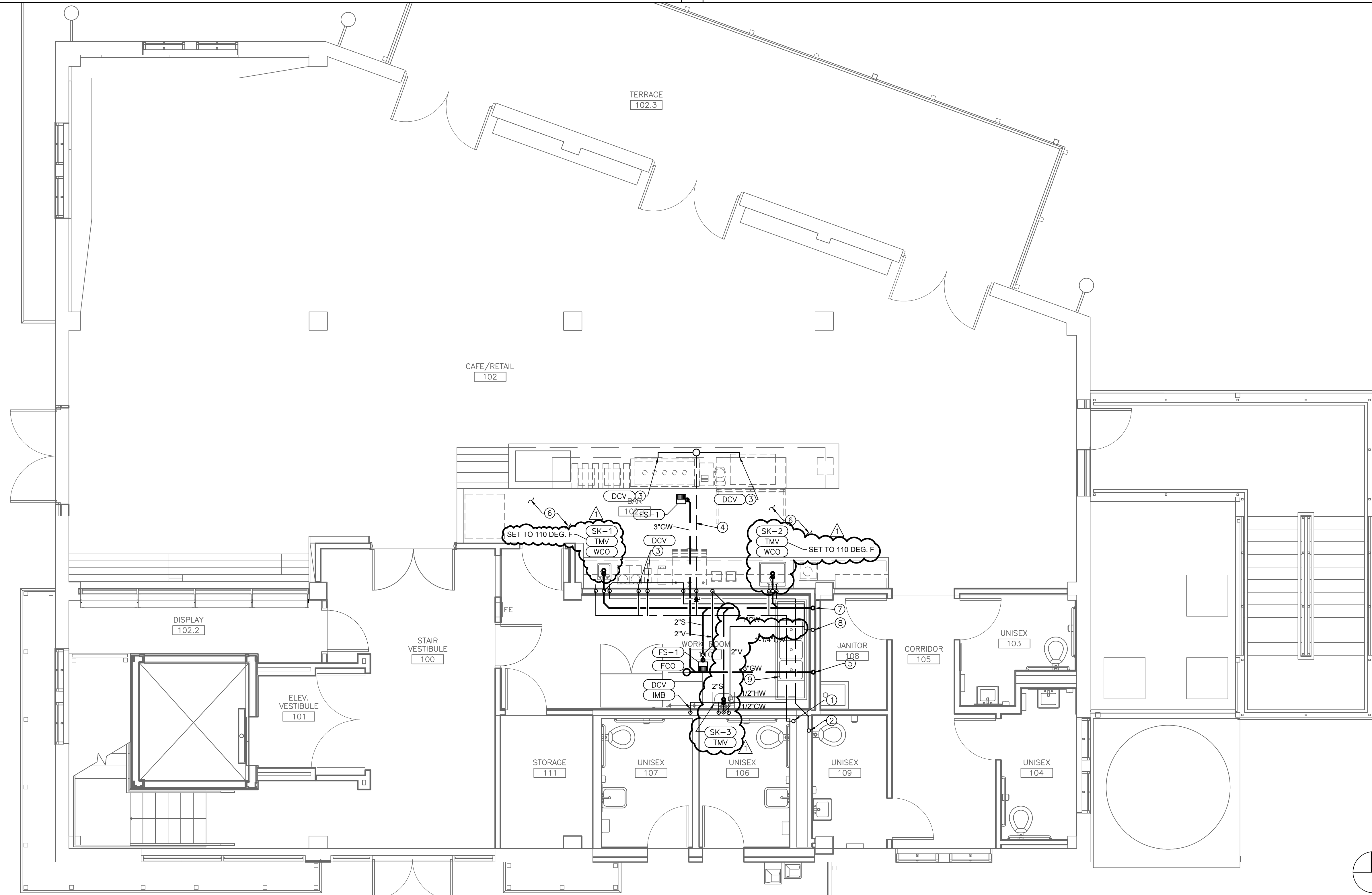

PLUMBING FLOOR PLAN - FIRST FLOOR

1/4" = 1'- 0" 3

GENERAL NOTES

- A. PROVIDE ADD-ALTERNATE COST TO REPLACE EXISTING HOT WATER HEATER ELEMENTS WITH (6) NEW 6KW ELEMENTS. HEATER IS LOCATED IN SECOND FLOOR JANITOR'S CLOSET.

KEY NOTES

- CONNECT TO EXISTING 2" DOMESTIC COLD WATER. PROVIDE ISOLATION VALVE FOR TENANT SHUT-OFF.
- CONNECT TO EXISTING 1" DOMESTIC HOT WATER. PROVIDE ISOLATION VALVE FOR TENANT SHUT-OFF.
- REFER TO BEVERAGE DISPENSER WATER DETAIL FOR CONNECTION TO OWNER-PROVIDED EQUIPMENT
- ROUTE 1" CW PIPING UNDER FLOOR TO UNDER COUNTER.
- CONNECT NEW 3" WASTE TO EXISTING 3" GREASE WASTE RISER IN THIS AREA.
- ADD/RELOCATE SPRINKLER HEADS ABOVE COFFEE SERVICE AREA TO ACCOMMODATE NEW CEILING.
- CONNECT NEW 2" SANITARY TO EXISTING 2" SANITARY RISER.
- CONNECT NEW 2" VENT TO EXISTING 2" VENT RISER.
- 3-COMPARTMENT SINK AND ASSOCIATED PLUMBING PIPING IS EXISTING TO REMAIN.



BRAVE / ARCHITECTURE

4617 Montrose Blvd., Suite C.230
Houston, Texas 77006
Voice: 713.524.5858
Fax: 713.524.5868
studio@bravearchitecture.com
Contact: Silvana Micolich
smicolich@bravearchitecture.com



Consultants:

MEP:

Collaborative Engineering Group
8904 Fairbanks N. Houston Suite 201
Houston, TX 77064
T: 281.598.1170
F: 281.598.1130



8904 Fairbanks N. Houston, Suite 201
Houston, Texas 77064
281.598.1170
www.collaborative-engr.com
Firm No. F12678

SUNSET COFFEE

1019 Commerce St.
Houston, TX 77002

Ownership of Instruments of Service:
All reports, plans, specifications, computer files, field data, notes & other documents and instruments prepared by BRAVE / ARCHITECTURE as instruments of service shall remain the property of BRAVE / ARCHITECTURE. BRAVE / ARCHITECTURE shall retain all common law, statutory and other reserved rights, including the copyright thereto.

ISSUE FOR PERMIT	02.25.2016
PERMIT RESPONSES	04.28.2016

B/A Project No.:	15137
Drawn By:	XX
Checked By:	XX
Date:	
Scale:	AS NOTED

PLUMBING FLOOR PLAN

P1.01