

2016 THEATER DISTRICT PARKING GARAGE SIGNAGE



WALKER
PARKING CONSULTANTS

DRAWING INDEX

NO:	SHEET NAME
G-000	COVER SHEET
PK-101A	GREEN GARAGE LEVEL 1 AREA A SIGNAGE PLAN
PK-101B	GREEN GARAGE LEVEL 1 AREA B SIGNAGE PLAN
PK-102A	GREEN GARAGE LEVEL 2 AREA A SIGNAGE PLAN
PK-102B	GREEN GARAGE LEVEL 2 AREA B SIGNAGE PLAN
PK-103A	GREEN GARAGE LEVEL 3 AREA A SIGNAGE PLAN
PK-103B	GREEN GARAGE LEVEL 3 AREA B SIGNAGE PLAN
PK-104	BLUE GARAGE LEVEL 1 SIGNAGE PLAN
PK-105	BLUE GARAGE LEVEL 2 SIGNAGE PLAN
PK-106	BLUE GARAGE LEVEL 3 SIGNAGE PLAN
PK-107	YELLOW GARAGE LEVEL 1 SIGNAGE PLAN
PK-108	YELLOW GARAGE LEVEL 2 SIGNAGE PLAN
PK-109	YELLOW GARAGE LEVEL 3 SIGNAGE PLAN
PK-200	VEHICULAR SIGNAGE DETAILS
PK-201	GREEN GARAGE SIGNAGE DETAILS
PK-202	GREEN GARAGE SIGNAGE DETAILS
PK-203	YELLOW GARAGE SIGNAGE DETAILS
PK-204	BLUE GARAGE SIGNAGE DETAILS
PK-206	STAIR VINYL
PK-207	STAIR VINYL
PK-208	STAIR VINYL
PK-209	STAIR VINYL
PK-210	STAIR VINYL
PK-211	STAIR VINYL

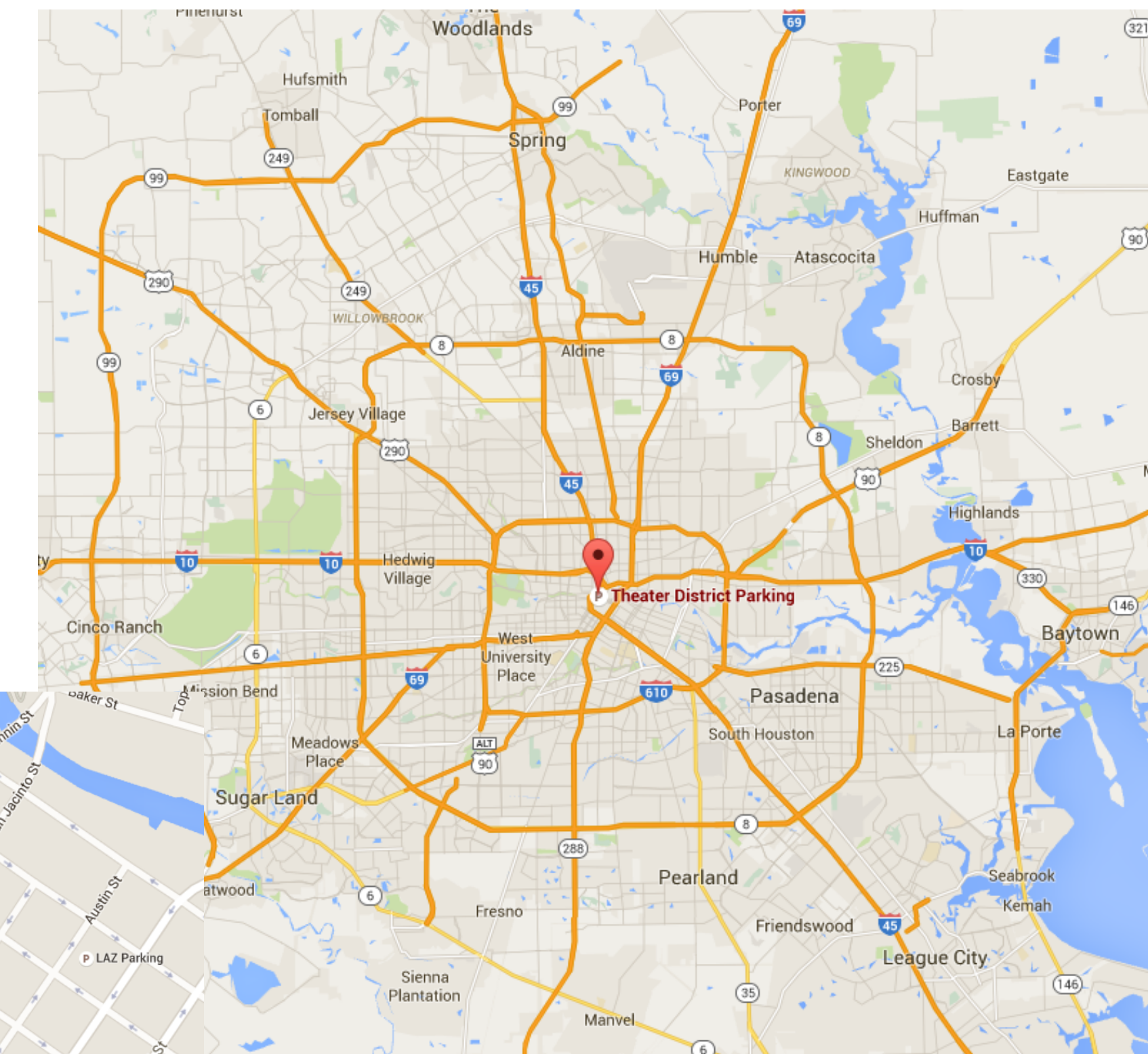

PROJECT LOCATION

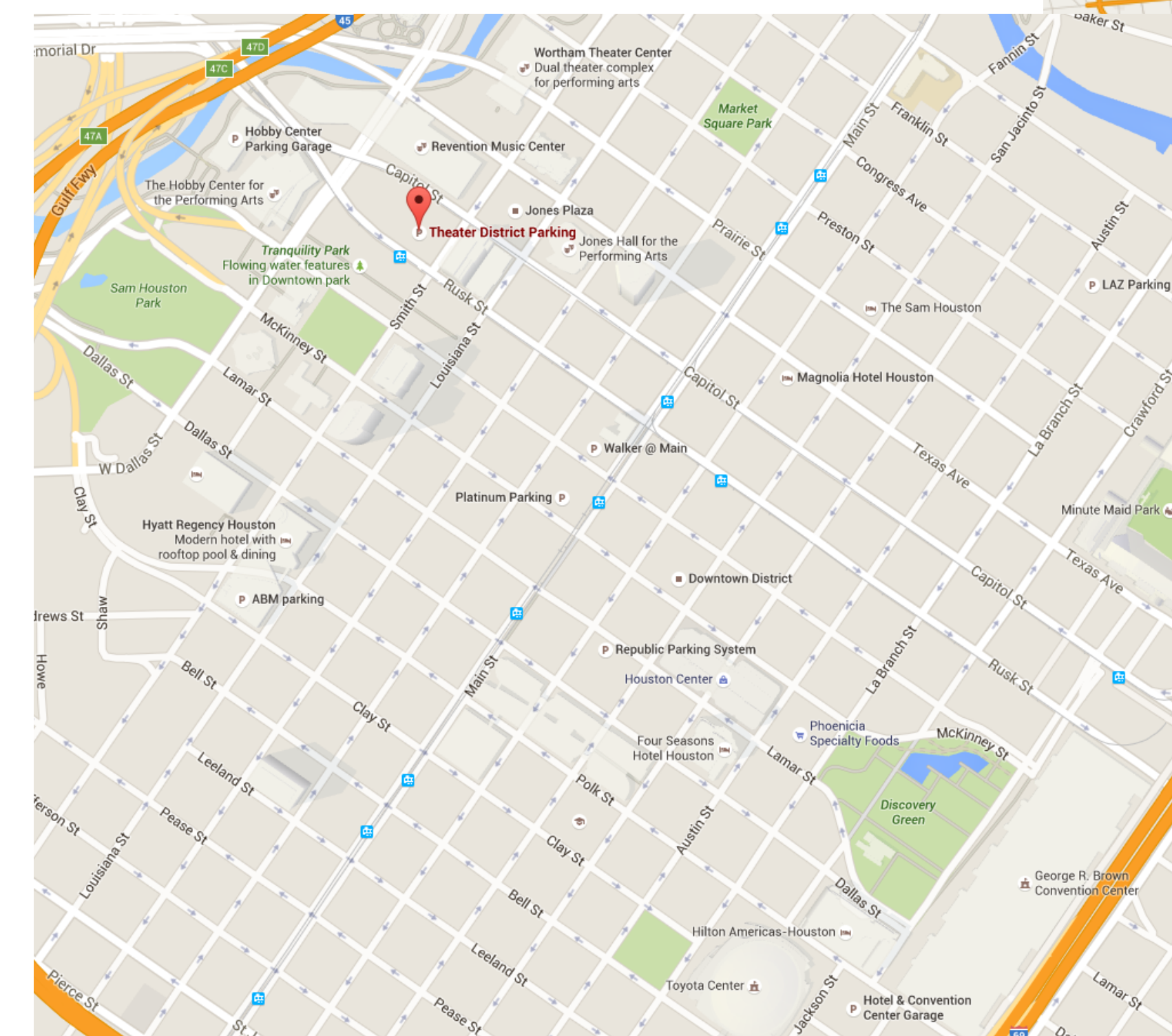

CODE SUMMARY

PROJECT GENERAL INFORMATION

NAME OF PROJECT:	THEATER DISTRICT PARKING SIGNAGE
BUILDING/FACILITY NAME:	THEATER DISTRICT PARKING GARAGE
LOCATION/ADDRESS:	511 Rusk St, Houston, TX 77002
DESCRIPTION OF PROJECT:	PARKING STRUCTURE
APPLICABLE BUILDING CODES:	2012 IBC WITH HOUSTON AMMENDMENTS 2012 TEXAS ACCESSIBILITY STANDARDS



HOUSTON THEATER DISTRICT
GARAGE SIGNAGE

HOUSTON

TEXAS



PROJECT NO:	25-1883.01	
DRAWN BY:	RG	
CHECKED BY:	JB	
SHEET TITLE:	LEVEL 1 A SIGNAGE PLAN	
NO.	DATE	DESCRIPTION
△	5-20-2016	Addendum #1
	3-24-2016	Construction Documents
ISSUED:		

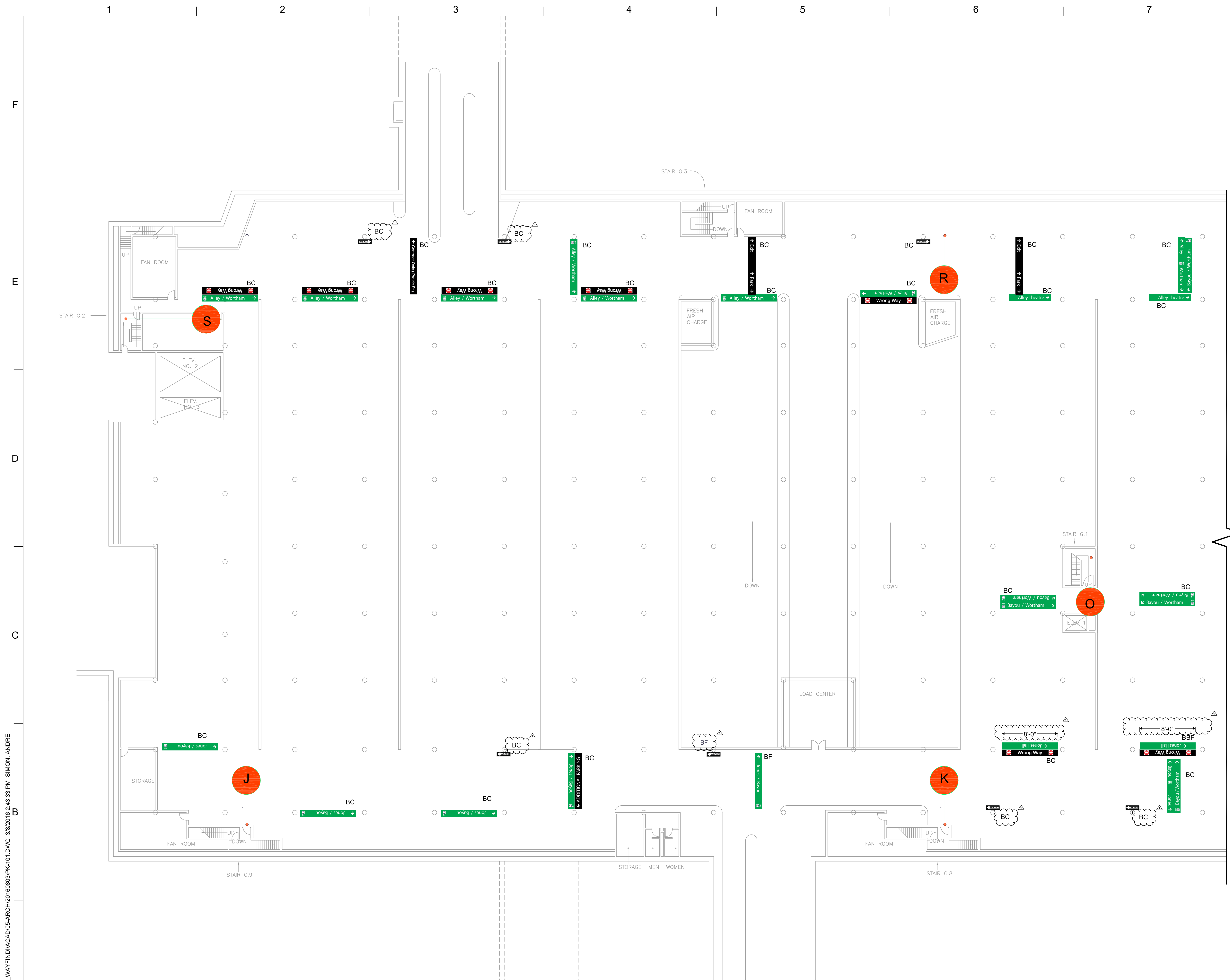

- GENERAL NOTES:**
1. MOUNT SIGNS AS LOW AS POSSIBLE MAINTAINING MINIMUM POSTED CLEAR HEIGHTS IN GARAGES.
 2. BC = "BELOW CEILING" RE: 5/PK-204
 BF = "BEAM FACE MOUNT" RE: 6/PK-204
 BBF = "BELOW BEAM FACE" RE: 5/PK-204 (SIMILAR)
 FC = "FROM CEILING MOUNT" RE: 5/PK-204
 3. FIELD VERIFY ALL LOCATIONS PRIOR TO SUBMITTING SHOP DRAWING TO CONFIRM ATTACHMENT METHODS AND SIGN VISIBILITY.
 4. ALL EXISTING PEDESTRIAN & VEHICULAR WAYFINDING OVERHEAD SIGNS SIMILAR IN PURPOSE TO THE NEW SIGNS ARE TO BE REMOVED. REGULATORY AND WALL MOUNTED SIGNS ARE TO REMAIN U.N.O
 5. PROVIDE 8-1/2"x11" COLOR RENDERING OF EACH VINYL SIGN AND SHOP DRAWINGS FOR EACH SIGN FOR OWNER AND ENGINEER REVIEW AND APPROVAL PRIOR TO PRODUCTION.
 6. SIGNAGE IS NOT DEPICTED TO SCALE. CONTRACTOR TO CONFIRM VIA SHOP DRAWING PROCESS THAT APPROPRIATE LETTER SIZE IS PROVIDED TO FIT DESIGNATED SIGN WIDTH.
 7. ALL SINGLE FACED HANGING SIGNS ARE TO RECEIVE A BLANK BLACK PANEL ATTACHED TO THE BACK SIDE OF FRAME.
 8. PER OWNER, THE GREEN GARAGE IS A POST TENSION STRUCTURE AND WILL REQUIRE SCAN BE PERFORMED PRIOR TO INSTALLATION OF SIGN SUPPORTS. BLUE AND YELLOW GARAGES DO NO REQUIRE SCANNING.

J:\25-1883-00-THEATER_DISTRICT_WAYFINDING\CAD\05-ARCH\20160803\PK-101.DWG 3/6/2016 2:43:33 PM SIMON, ANDRE

WALKER
 PARKING CONSULTANTS
 2525 Bay Area Boulevard
 Suite 400
 Houston, TX 77058
 (281) 280-0058 Pn
 (281) 280-0373 Fax
 www.walkerparking.com

Walker Parking Consultants/Engineers, Inc.
 Firm Certificate of Authority Number: F-004168

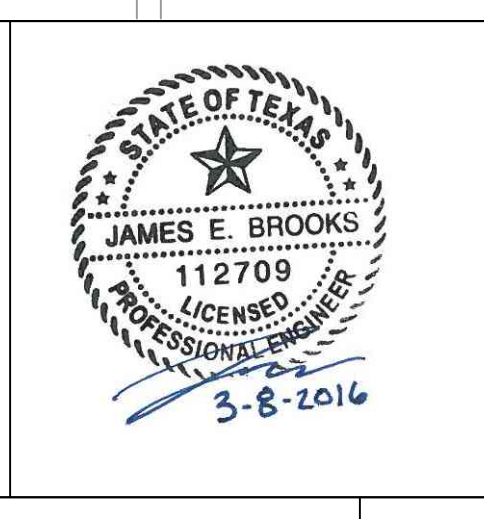

**HOUSTON THEATER DISTRICT
 GREEN GARAGE SIGNAGE**

HOUSTON TEXAS



NO.	DATE	DESCRIPTION
5-20-2016	5-20-2016	Addendum #1
3-24-2016	3-24-2016	Construction Documents
ISSUED:		

PROJECT NO:	25-1883.01
DRAWN BY:	RG
CHECKED BY:	JB
SHEET TITLE:	
LEVEL 1 A SIGNAGE PLAN	PK-101A



J:\25-1883-00-THEATER_DISTRICT_WAYFINDIACAD\05-ARCH\20160803\PK-101.DWG 3/6/2016 2:52:44 PM SIMON, ANDRE

WALKER
 PARKING CONSULTANTS
 2525 Bay Area Boulevard
 Suite 400
 Houston, TX 77058
 (281) 280-0058 Ph
 (281) 280-0373 Fax
 www.walkerparking.com



HOUSTON THEATER DISTRICT
 GREEN GARAGE SIGNAGE
 HOUSTON TEXAS



NO.	DATE	DESCRIPTION
△	5-20-2016	Addendum #1
	3-24-2016	Construction Documents

PROJECT NO:	25-1883.01
DRAWN BY:	RG
CHECKED BY:	JB
SHEET TITLE:	LEVEL 1 B SIGNAGE PLAN

PK-101B

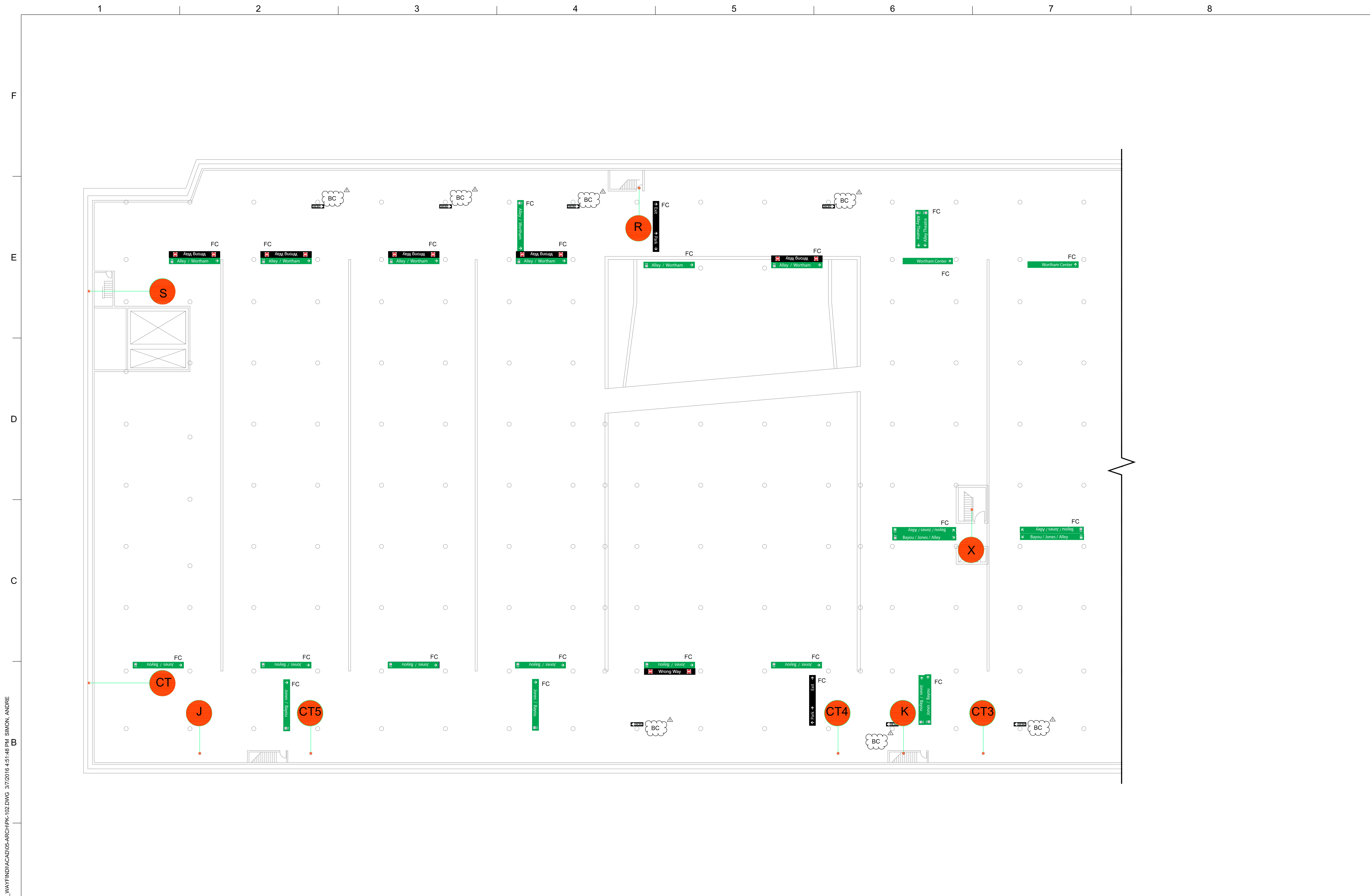

J:\25-1883-00-THEATER_DISTRICT_WAYFINDIACAD\05-ARCH\PK-102.DWG 3/7/2016 4:51:48 PM SIMON, ANDRE

WALKER
PARKING CONSULTANTS
2525 Bay Area Boulevard
Suite 400
Houston, TX 77058
(281) 280-0058 Ph
(281) 280-0373 Fax
www.walkerparking.com

Walker Parking Consultants/Engineers, Inc.
Firm Certificate of Authority Number: F-004168

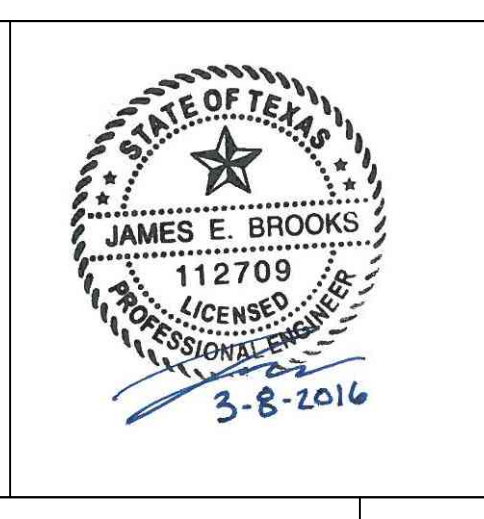

HOUSTON THEATER DISTRICT
GREEN GARAGE SIGNAGE

HOUSTON TEXAS



NO.	DATE	DESCRIPTION
△	5-20-2016	Addendum #1
	3-24-2016	Construction Documents

PROJECT NO:	25-1883.01
DRAWN BY:	RG
CHECKED BY:	JB
SHEET TITLE:	LEVEL 2 A SIGNAGE PLAN

PK102A

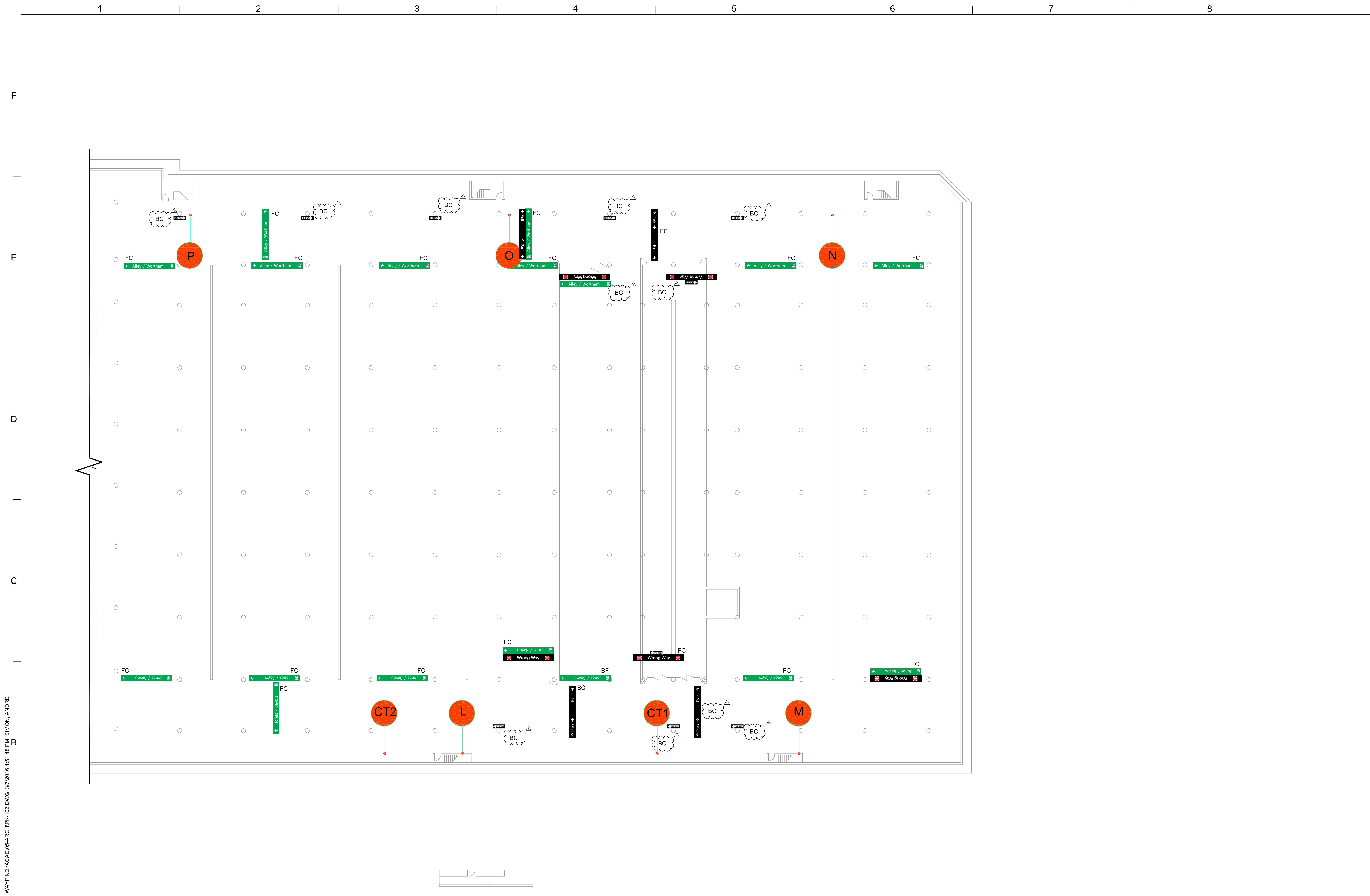

J:\25-1883-00-THEATER_DISTRICT_WAYFINDIACAD05-ARCH\PK-102.DWG 3/7/2016 4:51:48 PM SIMON, ANDRE

WALKER
 PARKING CONSULTANTS
 2525 Bay Area Boulevard
 Suite 400
 Houston, TX 77058
 (281) 280-0058 Ph
 (281) 280-0373 Fax
 www.walkerparking.com
 Walker Parking Consultants/Engineers, Inc.
 Firm Certificate of Authority Number: F-004168



HOUSTON THEATER DISTRICT
 GREEN GARAGE SIGNAGE
 HOUSTON TEXAS



NO.	DATE	DESCRIPTION
△	5-20-2016	Addendum #1
	3-24-2016	Construction Documents
ISSUED:		

PROJECT NO:	25-1883.01
DRAWN BY:	AAA
CHECKED BY:	BBB
SHEET TITLE:	
LEVEL 2 B SIGNAGE PLAN	

PK-102B

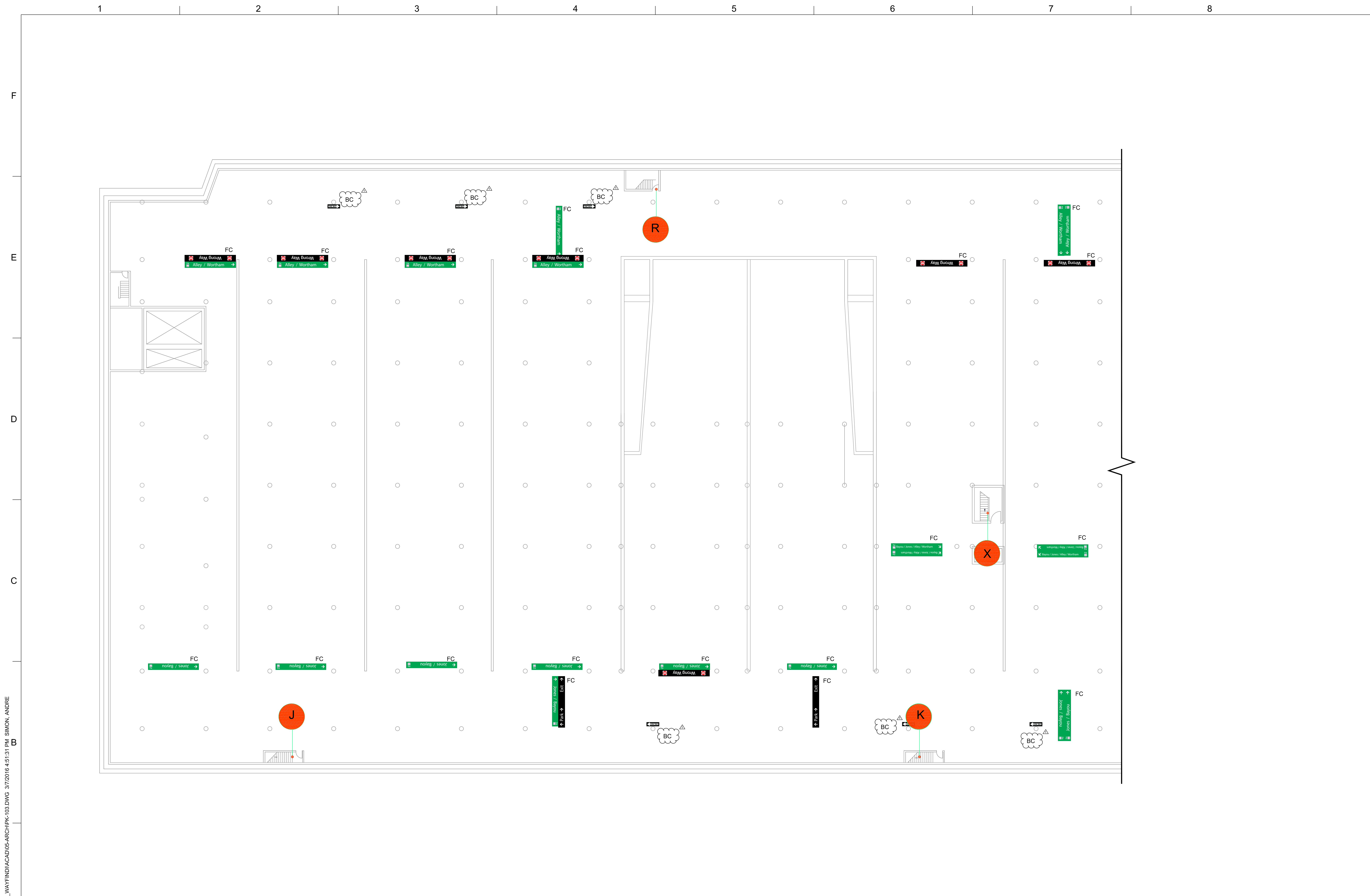

J:\25-1883-00-THEATER_DISTRICT_WAYFINDIACAD05-ARCHIPK-103.DWG 3/7/2016 4:51:31 PM SIMON, ANDRE

WALKER
 PARKING CONSULTANTS
 2525 Bay Area Boulevard
 Suite 400
 Houston, TX 77058
 (281) 280-0058 Ph
 (281) 280-0373 Fax
 www.walkerparking.com

Walker Parking Consultants/Engineers, Inc.
 Firm Certificate of Authority Number: F-004168



HOUSTON THEATER DISTRICT
 GREEN GARAGE SIGNAGE

HOUSTON TEXAS



NO.	DATE	DESCRIPTION
Δ	5-20-2016	Addendum #1
	3-24-2016	Construction Documents
ISSUED:		

PROJECT NO: 25-1883.01
 DRAWN BY: RG
 CHECKED BY: JB
 SHEET TITLE:
 LEVEL 3 A
 SIGNAGE
 PLAN

PK103A



J:\25-1883-00-THEATER_DISTRICT_WAYFINDIACAD05-ARCHIPK-103.DWG 3/7/2016 4:51:31 PM SIMON, ANDRE

WALKER
 PARKING CONSULTANTS
 2525 Bay Area Boulevard
 Suite 400
 Houston, TX 77058
 (281) 280-0688 Ph
 (281) 280-0373 Fax
 www.walkerparking.com



HOUSTON THEATER DISTRICT
 GREEN GARAGE SIGNAGE
 HOUSTON TEXAS



NO.	DATE	DESCRIPTION
△	5-20-2016	Addendum #1
	3-24-2016	Construction Documents

PROJECT NO:	25-1883.01
DRAWN BY:	RG
CHECKED BY:	JB
SHEET TITLE:	
LEVEL 3 B SIGNAGE PLAN	

PK-103B



J:\25-1883-00-THEATER_DISTRICT_WAYFINDIACAD\05-ARCH\PK-104.DWG 3/7/2016 3:18:43 PM SIMON, ANDRE

WALKER
 PARKING CONSULTANTS
 2525 Bay Area Boulevard
 Suite 400
 Houston, TX 77058
 (281) 280-0058 Pn
 (281) 280-0373 Fax
 www.walkerparking.com
 Walker Parking Consultants/Engineers, Inc.
 Firm Certificate of Authority Number: F-004168

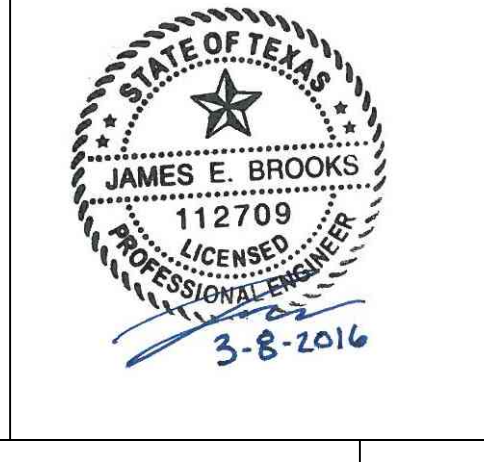

HOUSTON THEATER DISTRICT
 BLUE GARAGE SIGNAGE
 HOUSTON TEXAS



NO.	DATE	DESCRIPTION
△	5-20-2016	Addendum #1
	3-24-2016	Construction Documents

PROJECT NO:	25-1883.01
DRAWN BY:	RG
CHECKED BY:	JB
SHEET TITLE:	LEVEL 1 SIGNAGE PLAN

PK-104

J:\25-1883-00-THEATER_DISTRICT_WAYFINDING\05-ARCH\PK-105.DWG 3/7/2016 4:51:18 PM SIMON, ANDRE

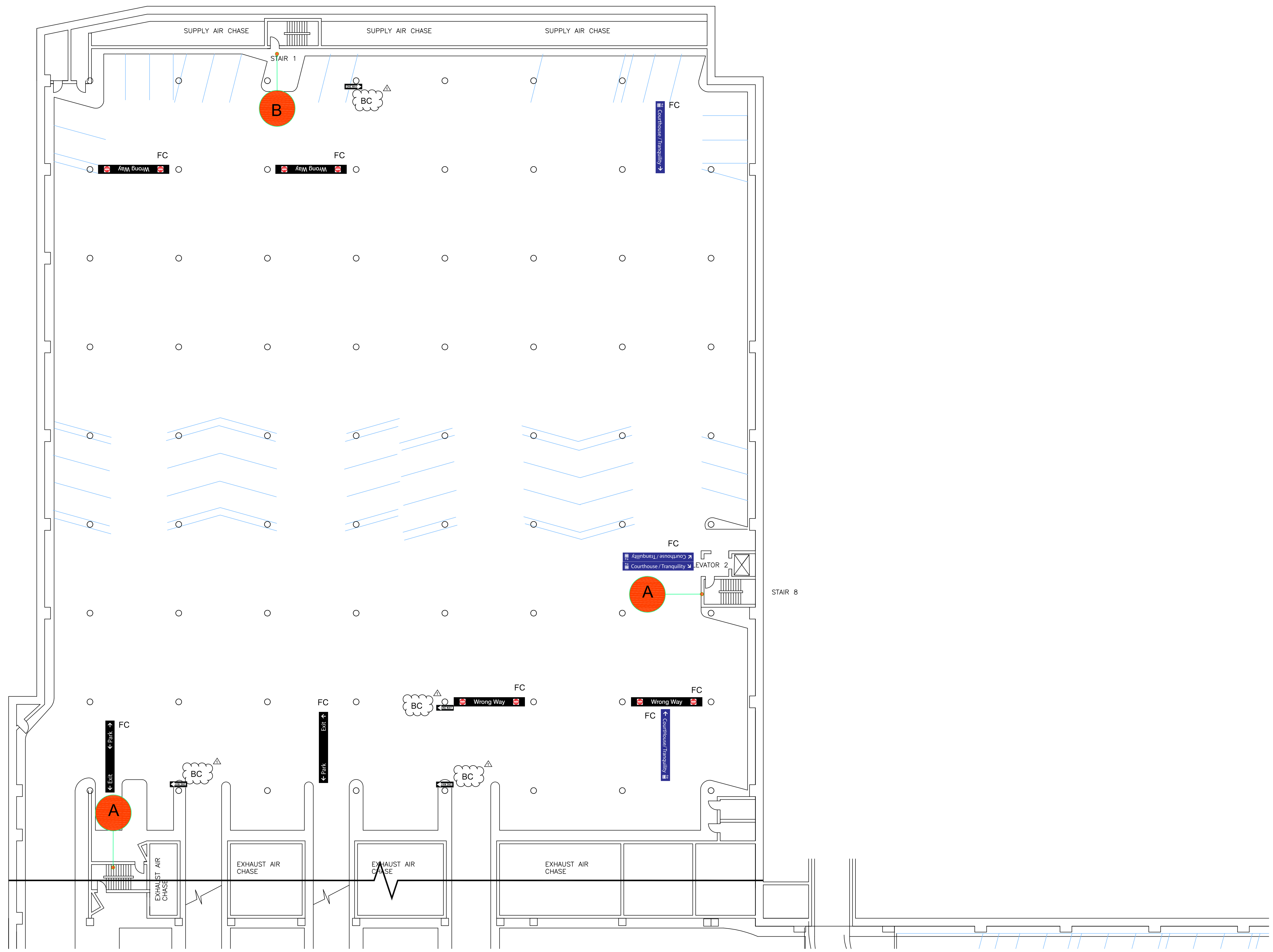

WALKER
PARKING CONSULTANTS
2525 Bay Area Boulevard
Suite 400
Houston, TX 77058
(281) 280-0088 Ph
(281) 280-0373 Fax
www.walkerparking.com



HOUSTON THEATER DISTRICT
BLUE GARAGE SIGNAGE
HOUSTON TEXAS



NO.	DATE	DESCRIPTION
△	5-20-2016	Addendum #1
	3-24-2016	Construction Documents

PROJECT NO:	25-1883.01
DRAWN BY:	RG
CHECKED BY:	JB
SHEET TITLE:	LEVEL 2 SIGNAGE PLAN

PK-105

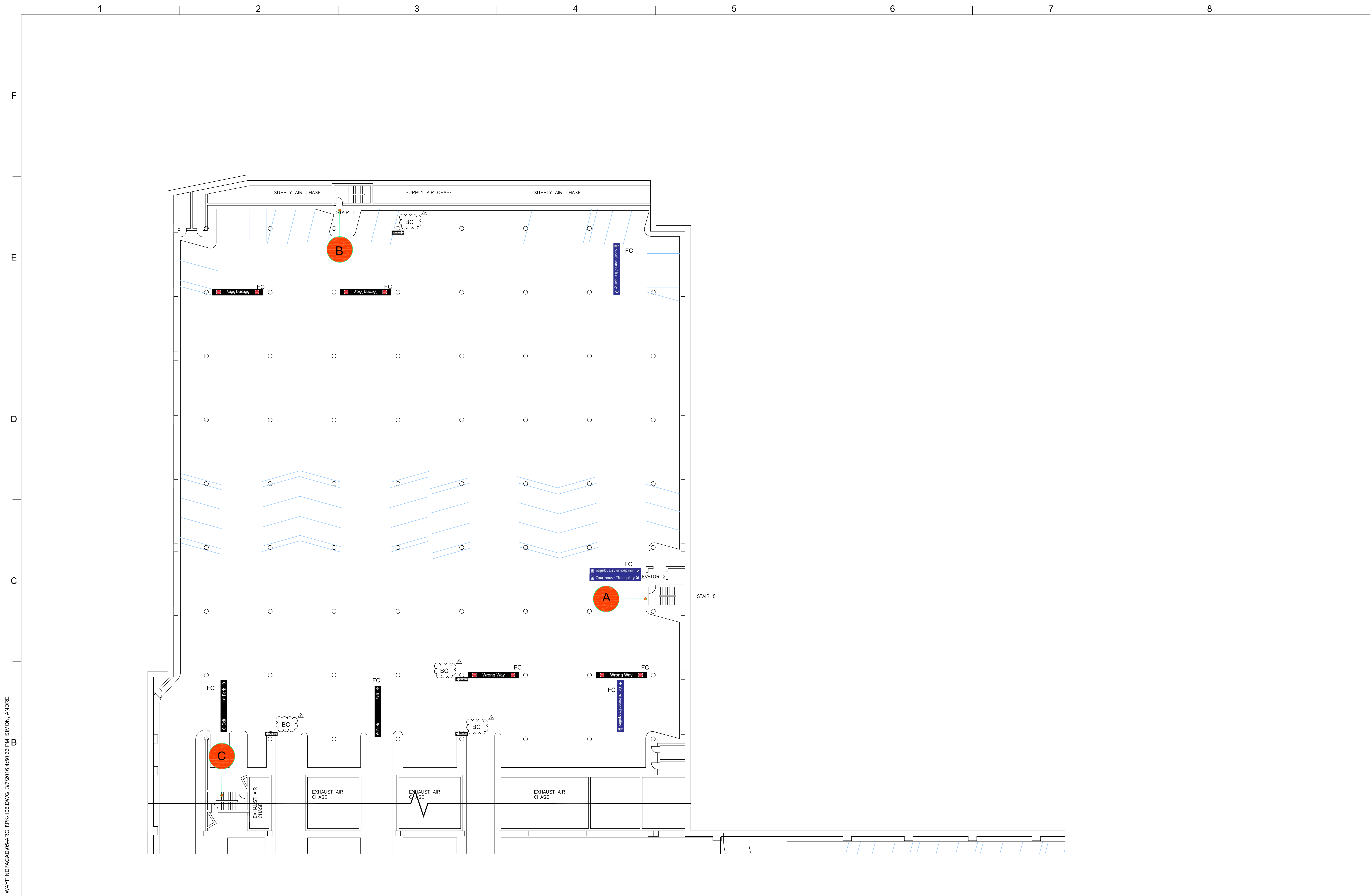

J:\25-1883-00-THEATER_DISTRICT_WAYFINDIACAD\05-ARCH\PK-106.DWG 3/7/2016 4:50:33 PM SIMON, ANDRE

WALKER
 PARKING CONSULTANTS
 2525 Bay Area Boulevard
 Suite 400
 Houston, TX 77058
 (281) 280-0058 Ph
 (281) 280-0373 Fax
 www.walkerparking.com

Walker Parking Consultants/Engineers, Inc.
 Firm Certificate of Authority Number: F-004168



HOUSTON THEATER DISTRICT
 BLUE GARAGE SIGNAGE
 HOUSTON TEXAS



NO.	DATE	DESCRIPTION
△	5-20-2016	Addendum #1
	3-24-2016	Construction Documents

PROJECT NO: 25-1883.01
 DRAWN BY: RG
 CHECKED BY: JB
 SHEET TITLE:
**LEVEL 3
 SIGNAGE
 PLAN**

PK-106

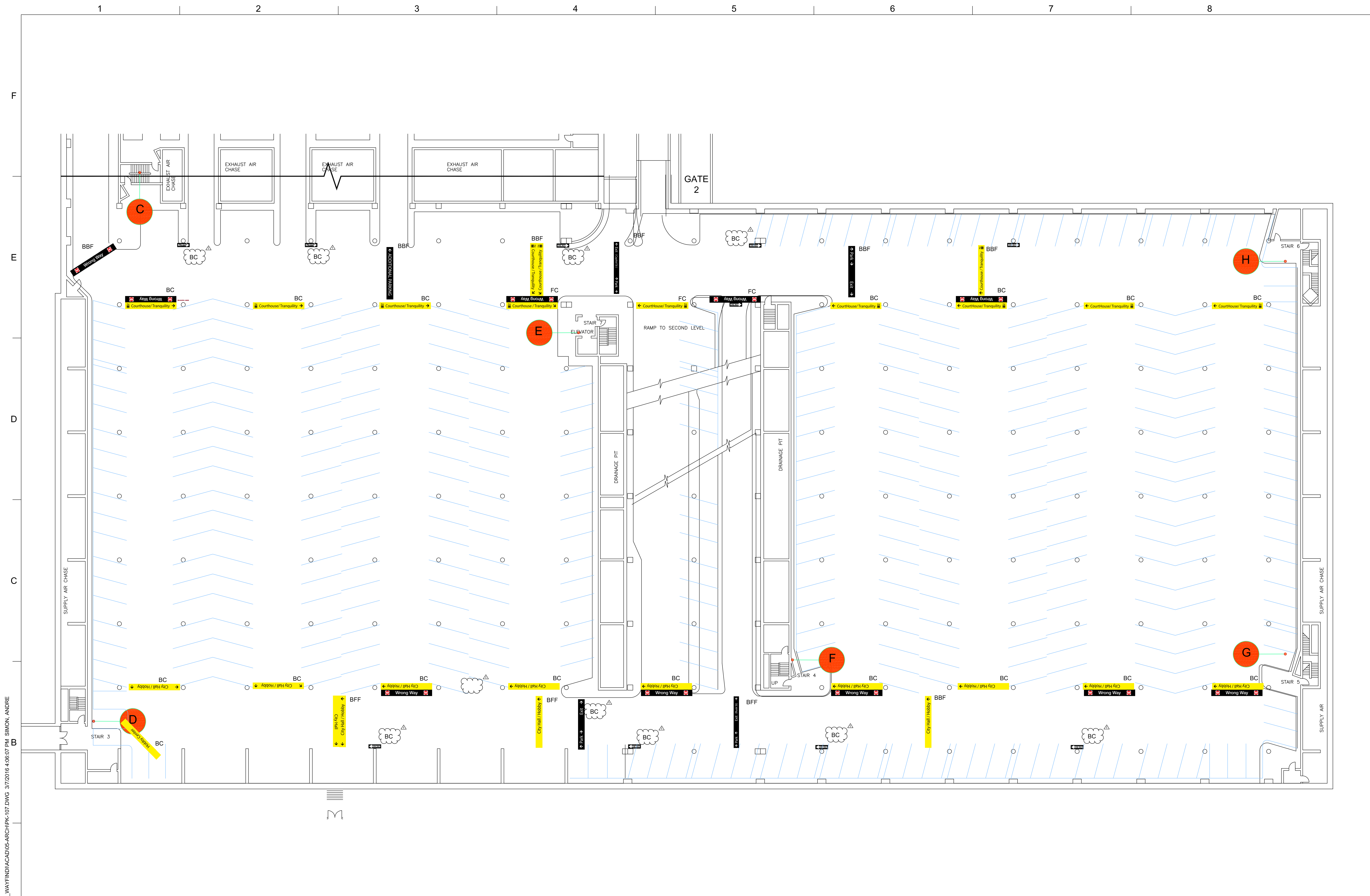

J:\25-1883-00-THEATER_DISTRICT_WAYFINDING\05-ARCH\PK-107.DWG 3/7/2016 4:06:07 PM SIMON, ANDRE

WALKER
 PARKING CONSULTANTS
 2525 Bay Area Boulevard
 Suite 400
 Houston, TX 77058
 (281) 280-0088 Ph
 (281) 280-0373 Fax
 www.walkerparking.com



HOUSTON THEATER DISTRICT
 YELLOW GARAGE SIGNAGE
 HOUSTON TEXAS



NO.	DATE	DESCRIPTION
△	5-20-2016	Addendum #1
	3-24-2016	Construction Documents

PROJECT NO:	25-1883.01
DRAWN BY:	RG
CHECKED BY:	JB
SHEET TITLE:	LEVEL 1 SIGNAGE PLAN

PK-107

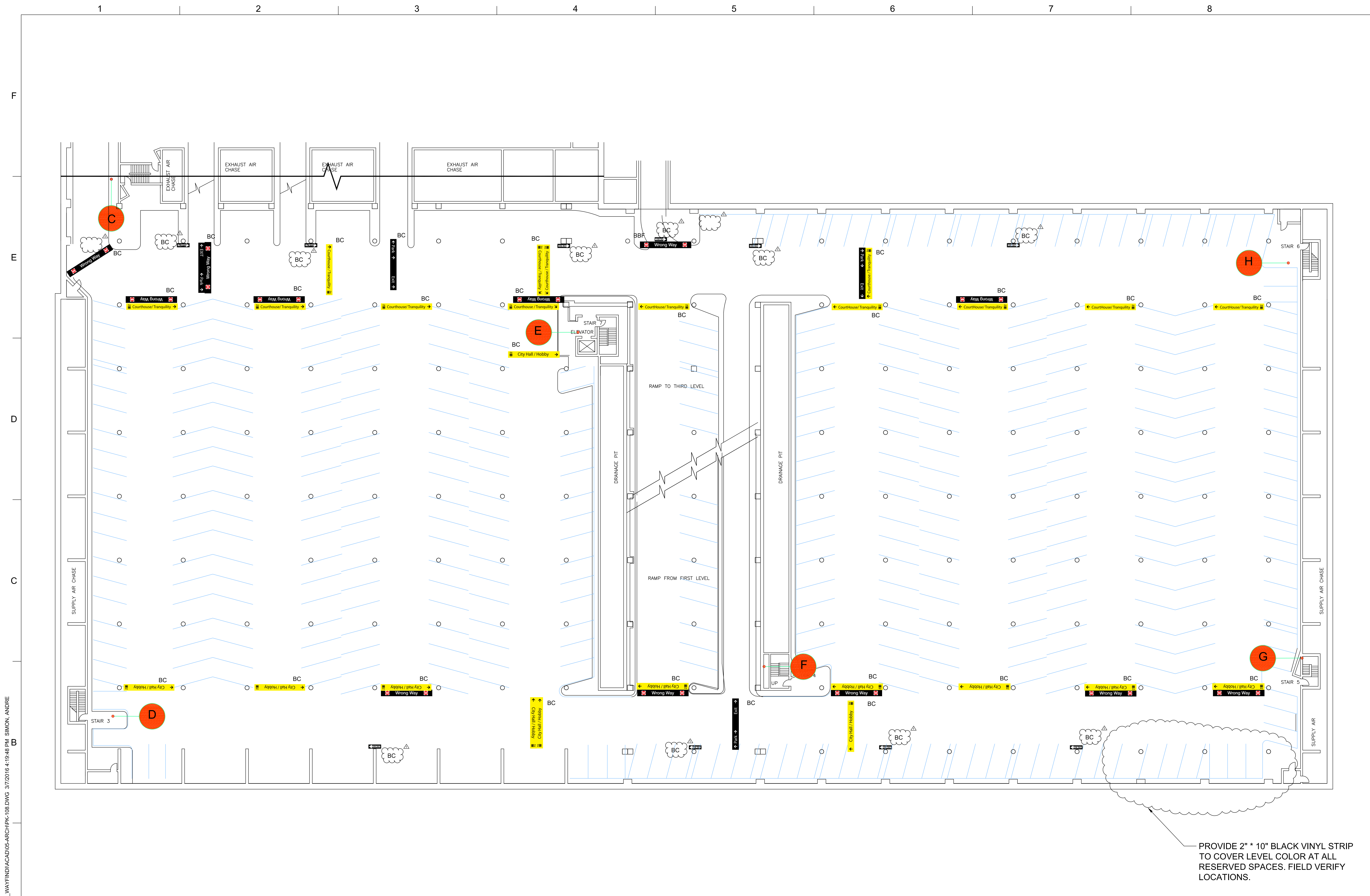

J:\25-1883-00-THEATER_DISTRICT_WAYFINDING\ACAD\05-ARCH\PK-108.DWG 3/7/2016 4:19:48 PM SIMON, ANDRE

WALKER
 PARKING CONSULTANTS
 2525 Bay Area Boulevard
 Suite 400
 Houston, TX 77058
 (281) 280-0688 Ph
 (281) 280-0373 Fax
 www.walkerparking.com

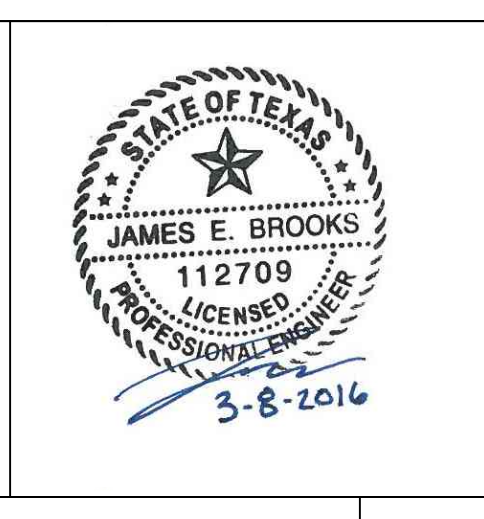

HOUSTON THEATER DISTRICT
 YELLOW GARAGE SIGNAGE
 HOUSTON TEXAS



NO.	DATE	DESCRIPTION
Δ	5-20-2016	Addendum #1
	3-24-2016	Construction Documents

PROJECT NO:	25-1883.01
DRAWN BY:	RG
CHECKED BY:	JB
SHEET TITLE:	LEVEL 2 SIGNAGE PLAN

PK-108

J:\25-1883-00-THEATER_DISTRICT_WAYFINDING\05-ARCH\PK-109.DWG 3/22/2016 4:42:46 PM SIMON, ANDRE

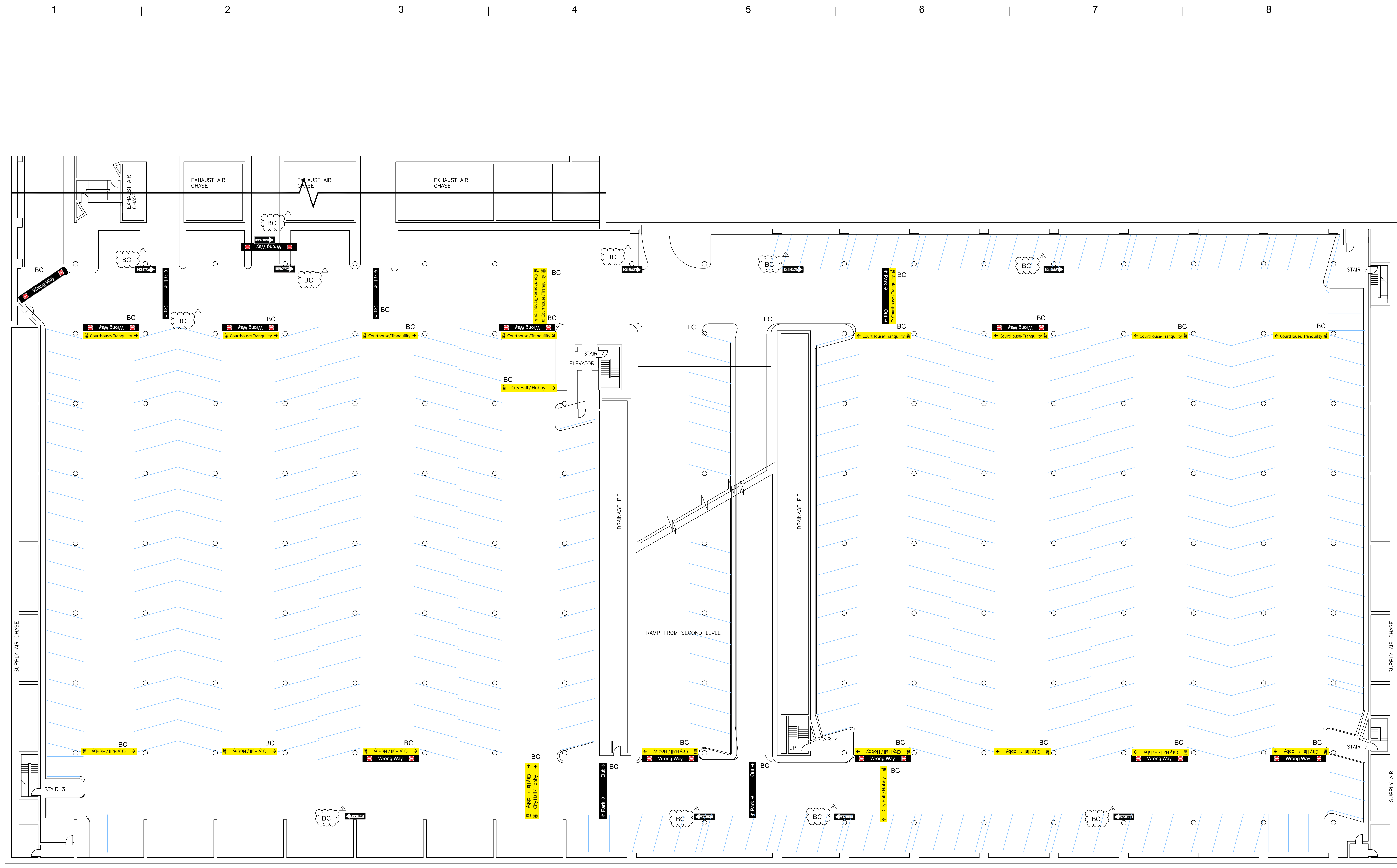

WALKER
 PARKING CONSULTANTS
 2525 Bay Area Boulevard
 Suite 400
 Houston, TX 77058
 (281) 280-0088 Ph
 (281) 280-0373 Fax
 www.walkerparking.com

Walker Parking Consultants/Engineers, Inc.
 Firm Certificate of Authority Number: F-004168



HOUSTON THEATER DISTRICT
 YELLOW GARAGE SIGNAGE
 HOUSTON TEXAS



NO.	DATE	DESCRIPTION
△	5-20-2016	Addendum #1
	3-24-2016	Construction Documents

PROJECT NO:	25-1883.01
DRAWN BY:	RG
CHECKED BY:	JB
SHEET TITLE:	LEVEL 3 SIGNAGE PLAN

PK-109

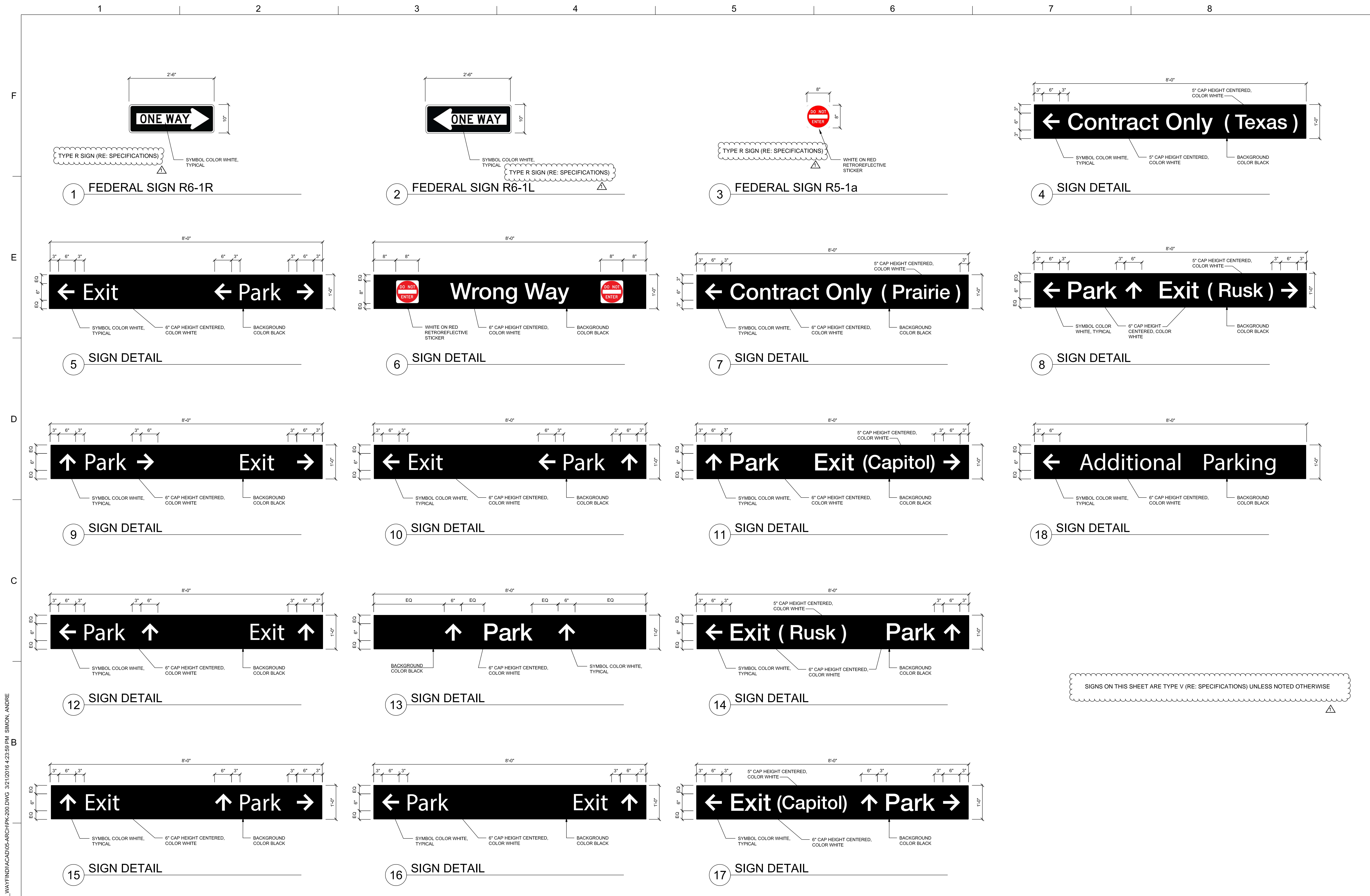

SIGNS ON THIS SHEET ARE TYPE V (RE: SPECIFICATIONS) UNLESS NOTED OTHERWISE

J:\25-1883-00-THEATER_DISTRICT_WAYFINDING\ARCH\PK-200.DWG 3/21/2016 4:23:59 PM SIMON, ANDRE

WALKER
PARKING CONSULTANTS
2525 Bay Area Boulevard
Suite 400
Houston, TX 77058
(281) 280-0058 Ph
(281) 280-0373 Fax
www.walkerparking.com

STATE OF TEXAS
JAMES E. BROOKS
12709
LICENSED PROFESSIONAL ENGINEER
3-23-2016

HOUSTON THEATER DISTRICT
GREEN GARAGE SIGNAGE
HOUSTON TEXAS

Houstonfirst

NO.	DATE	DESCRIPTION
△	5-20-2016	Addendum #1
	3-24-2016	Construction Documents

PROJECT NO:	25-1883.01
DRAWN BY:	RG
CHECKED BY:	BBB
SHEET TITLE:	SIGNAGE DETAILS
	PK-200

SIGNS ON THIS SHEET ARE TYPE PP (RE: SPECIFICATIONS) UNLESS NOTED OTHERWISE

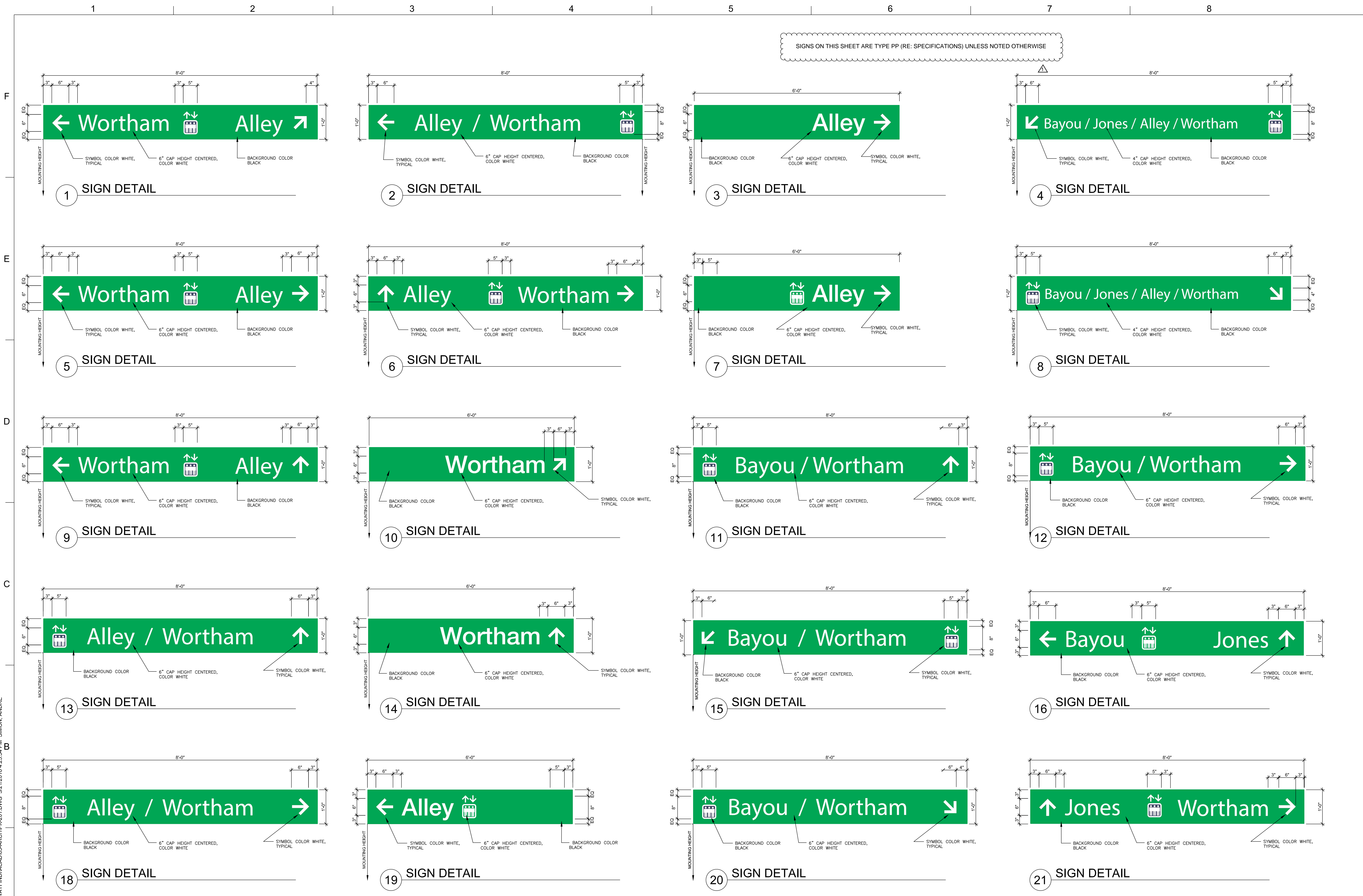

J:\25-1883-00-THEATER_DISTRICT_WAYFINDING\05-ARCH\PK-201.DWG 3/21/2016 4:23:54 PM SIMON, ANDRE



HOUSTON THEATER DISTRICT
GREEN GARAGE SIGNAGE
HOUSTON TEXAS



NO.	DATE	DESCRIPTION
5-20-2016	3-24-2016	Addendum #1 Construction Documents
ISSUED:		

PROJECT NO:	25-1883.01
DRAWN BY:	RG
CHECKED BY:	BBB
SHEET TITLE:	SIGNAGE DETAILS

PK-201

J:\25-1883-00-THEATER_DISTRICT_WAYFINDING\05-ARCH\PK-202.DWG 3/21/2016 4:23:49 PM SIMON, ANDRE

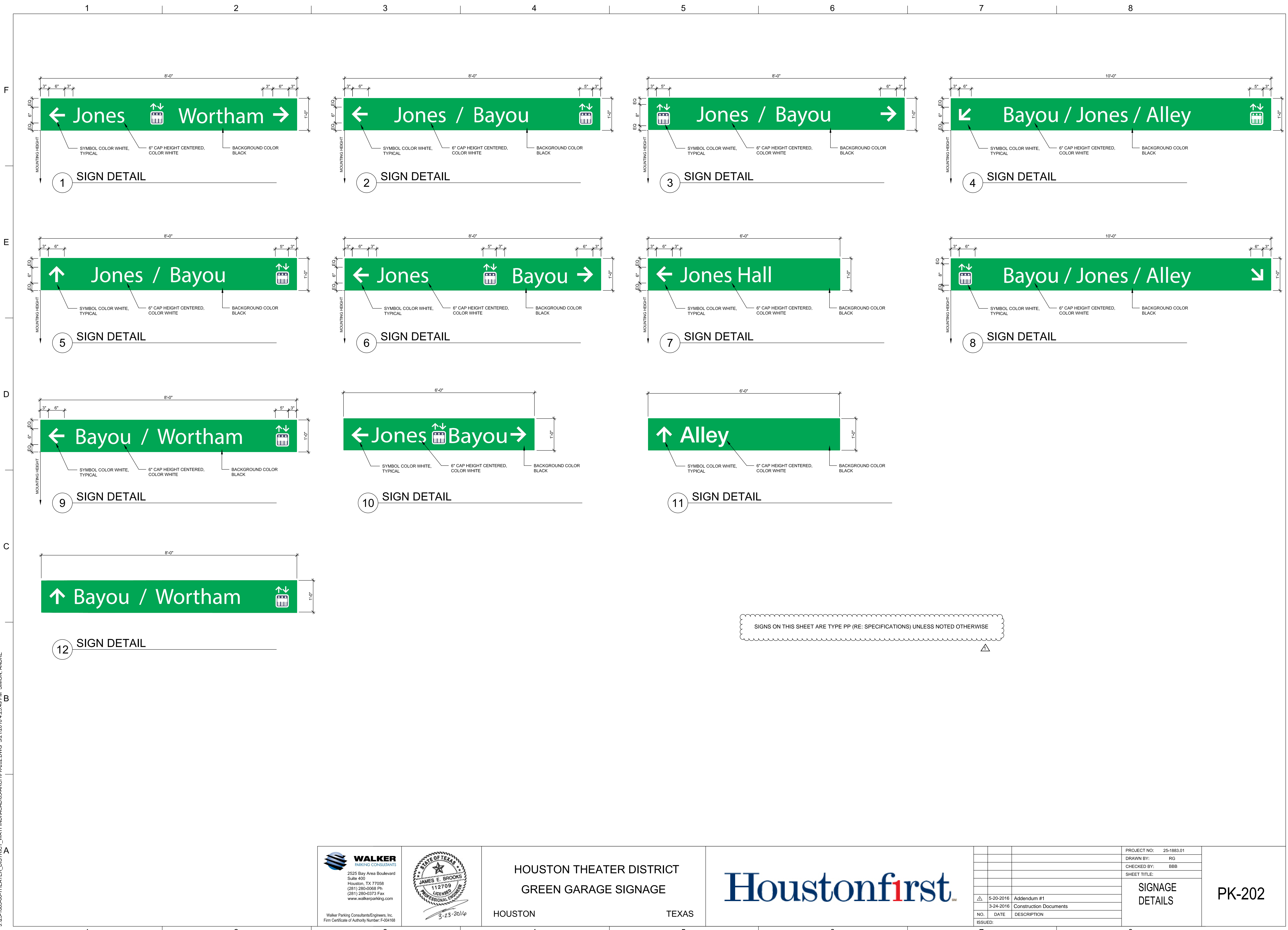

WALKER
PARKING CONSULTANTS
2525 Bay Area Boulevard
Suite 400
Houston, TX 77058
(281) 280-0058 Ph
(281) 280-0373 Fax
www.walkerparking.com

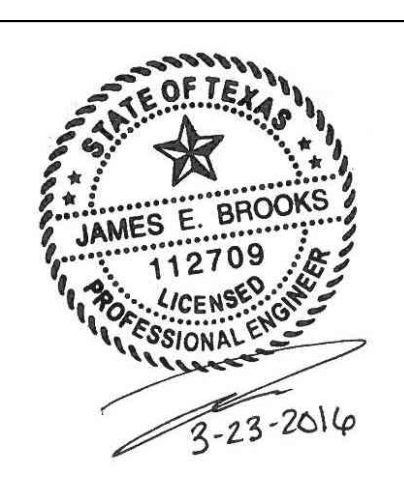

HOUSTON THEATER DISTRICT
GREEN GARAGE SIGNAGE
HOUSTON TEXAS



NO.	DATE	DESCRIPTION
△	5-20-2016	Addendum #1
	3-24-2016	Construction Documents

PROJECT NO:	25-1883.01
DRAWN BY:	RG
CHECKED BY:	BBB
SHEET TITLE:	SIGNAGE DETAILS

PK-202

J:\25-1883-00-THEATER_DISTRICT_WAYFINDING\05-ARCH\PK-203.DWG 3/21/2016 4:24:37 PM SIMON, ANDRE

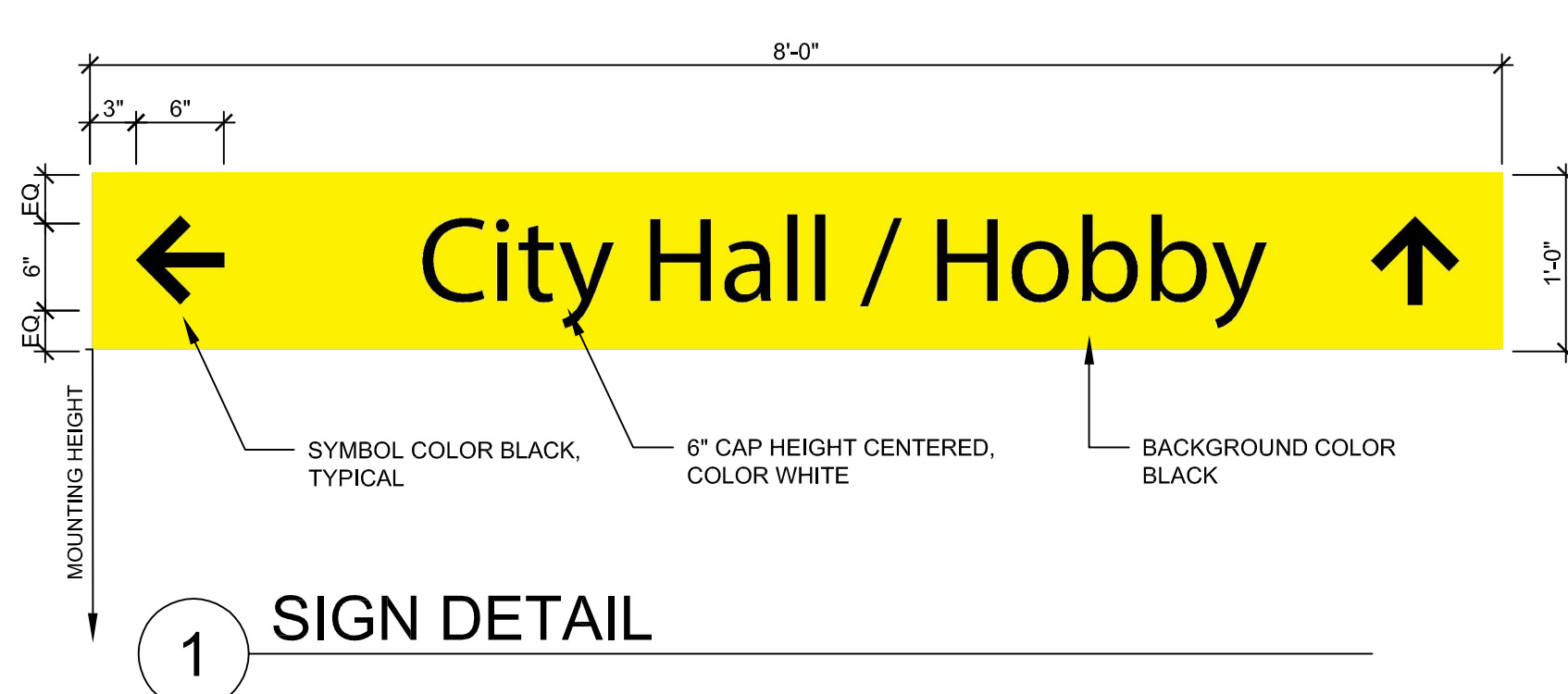

1 SIGN DETAIL

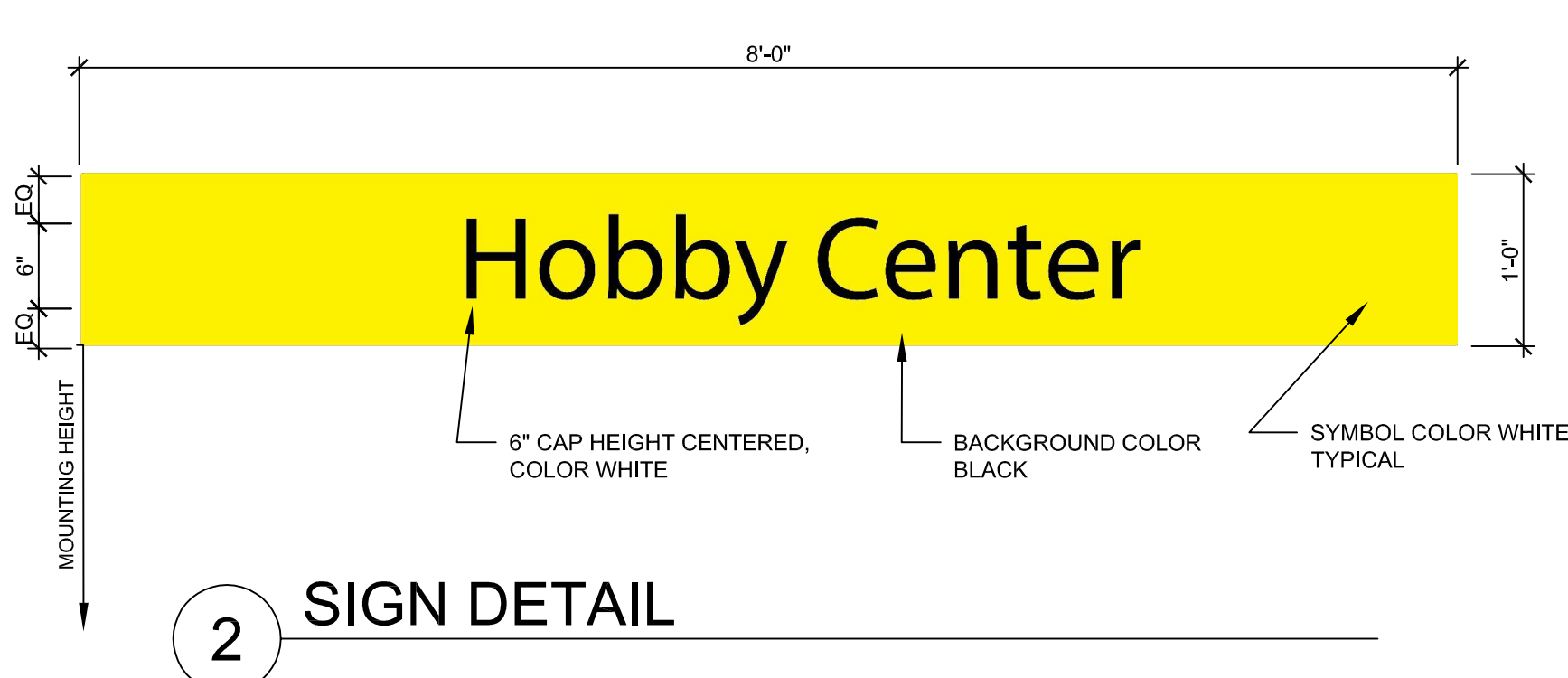

2 SIGN DETAIL

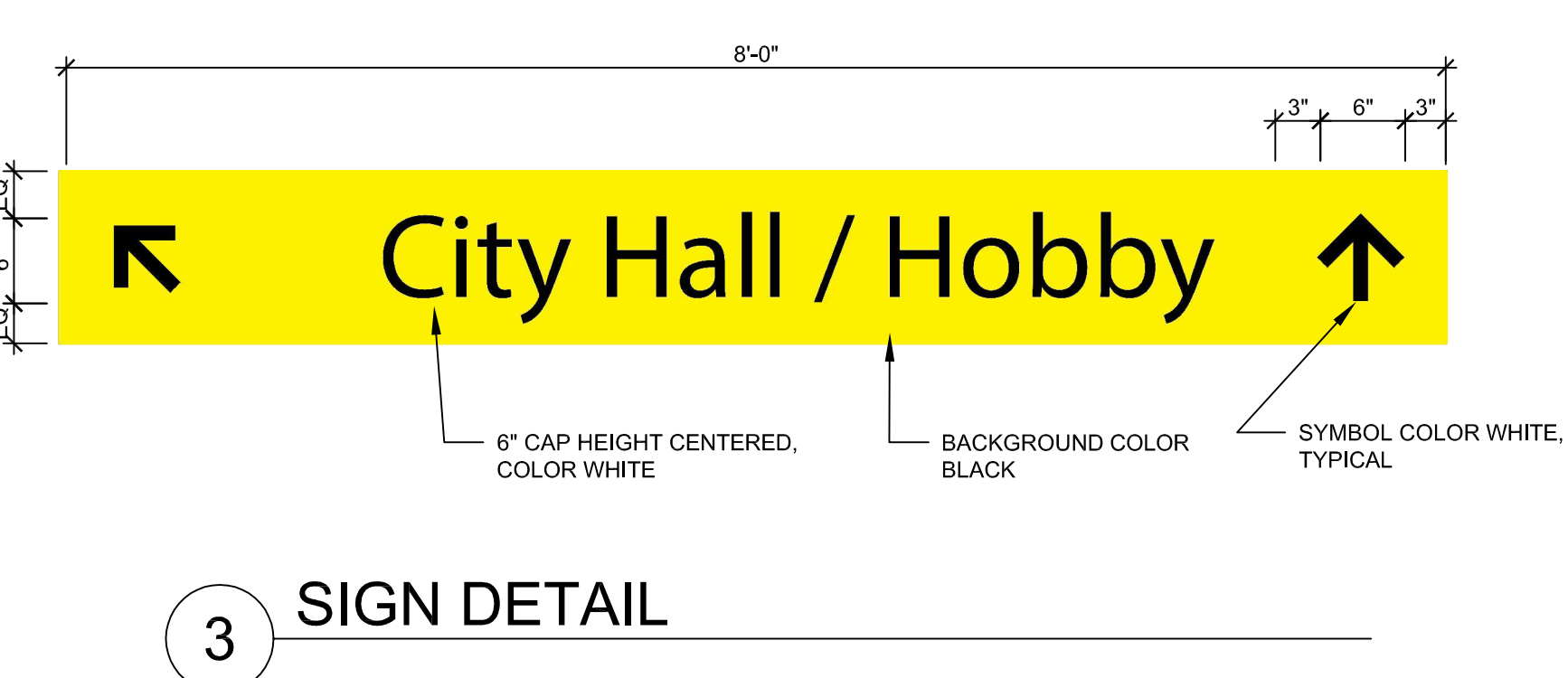

3 SIGN DETAIL

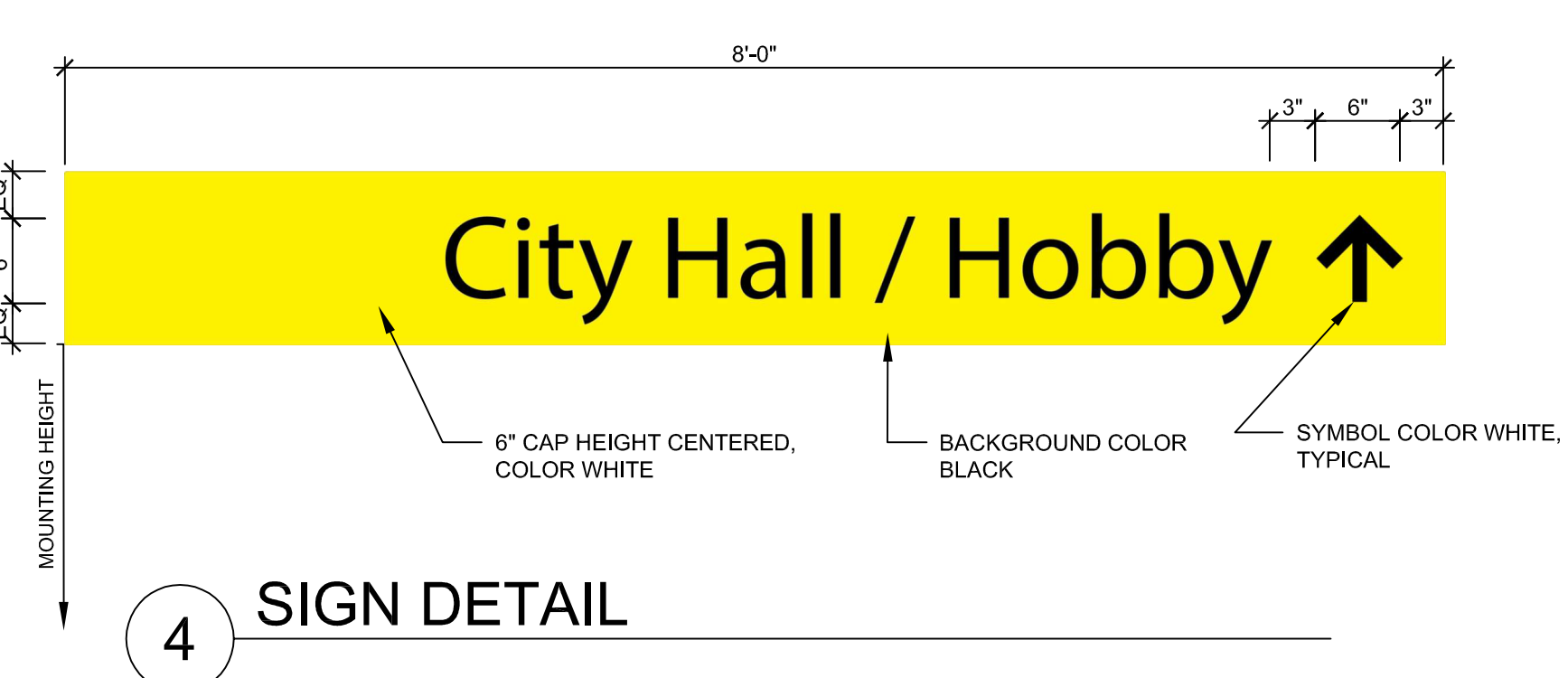

4 SIGN DETAIL

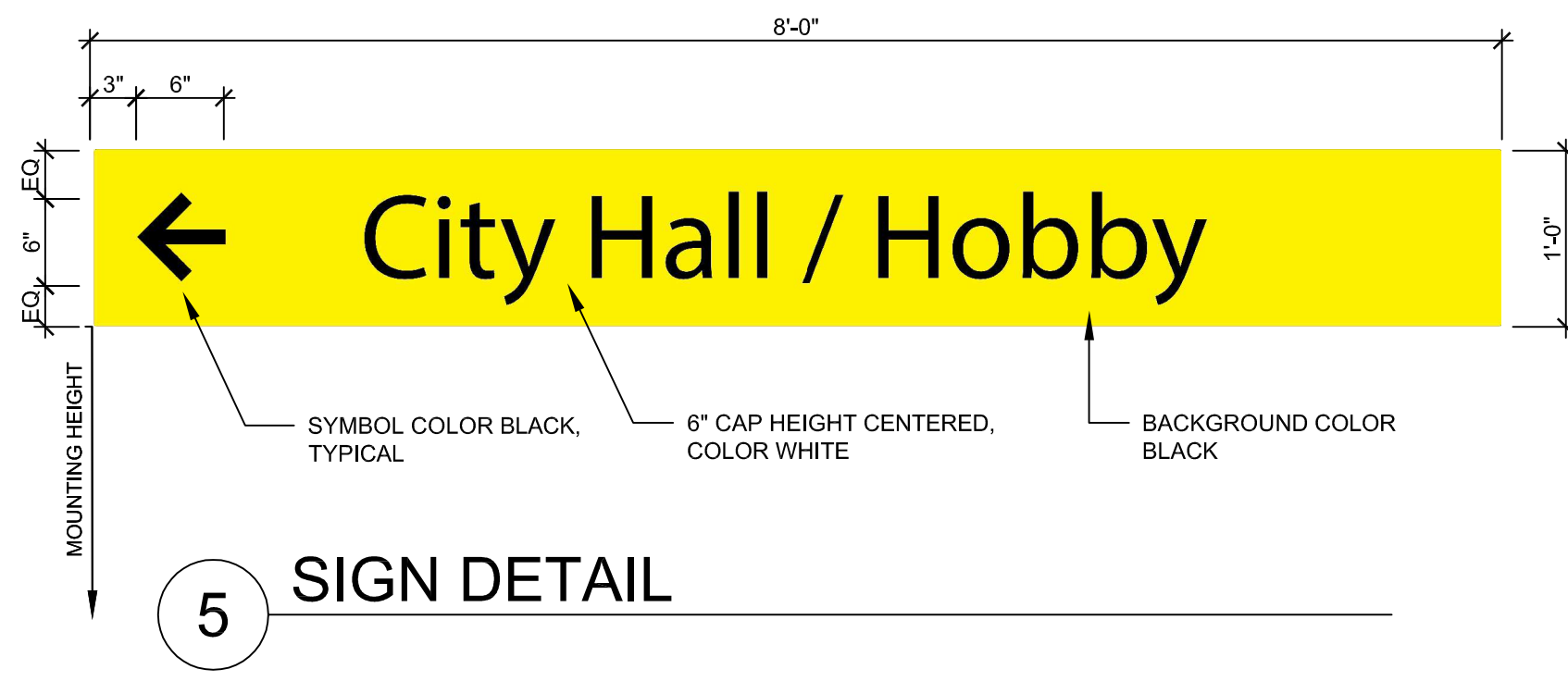

5 SIGN DETAIL

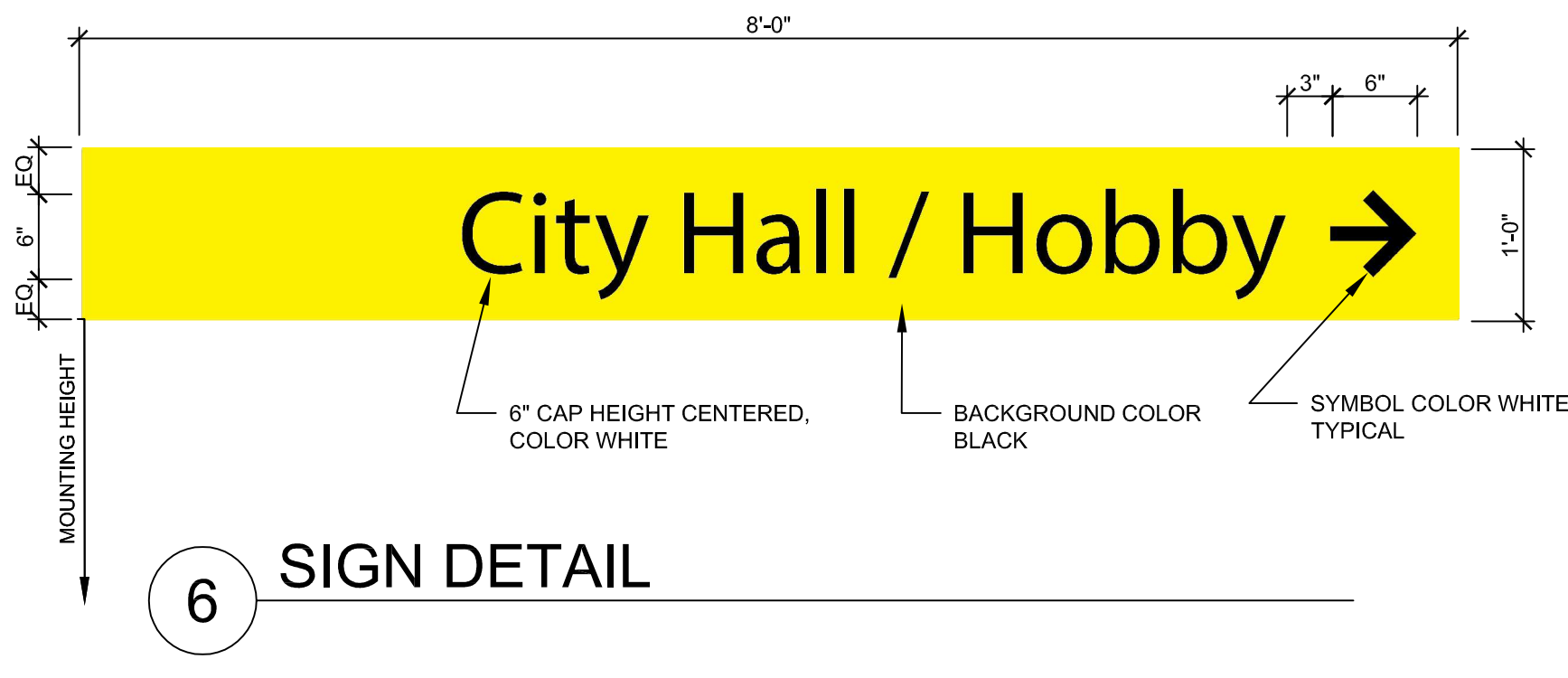

6 SIGN DETAIL

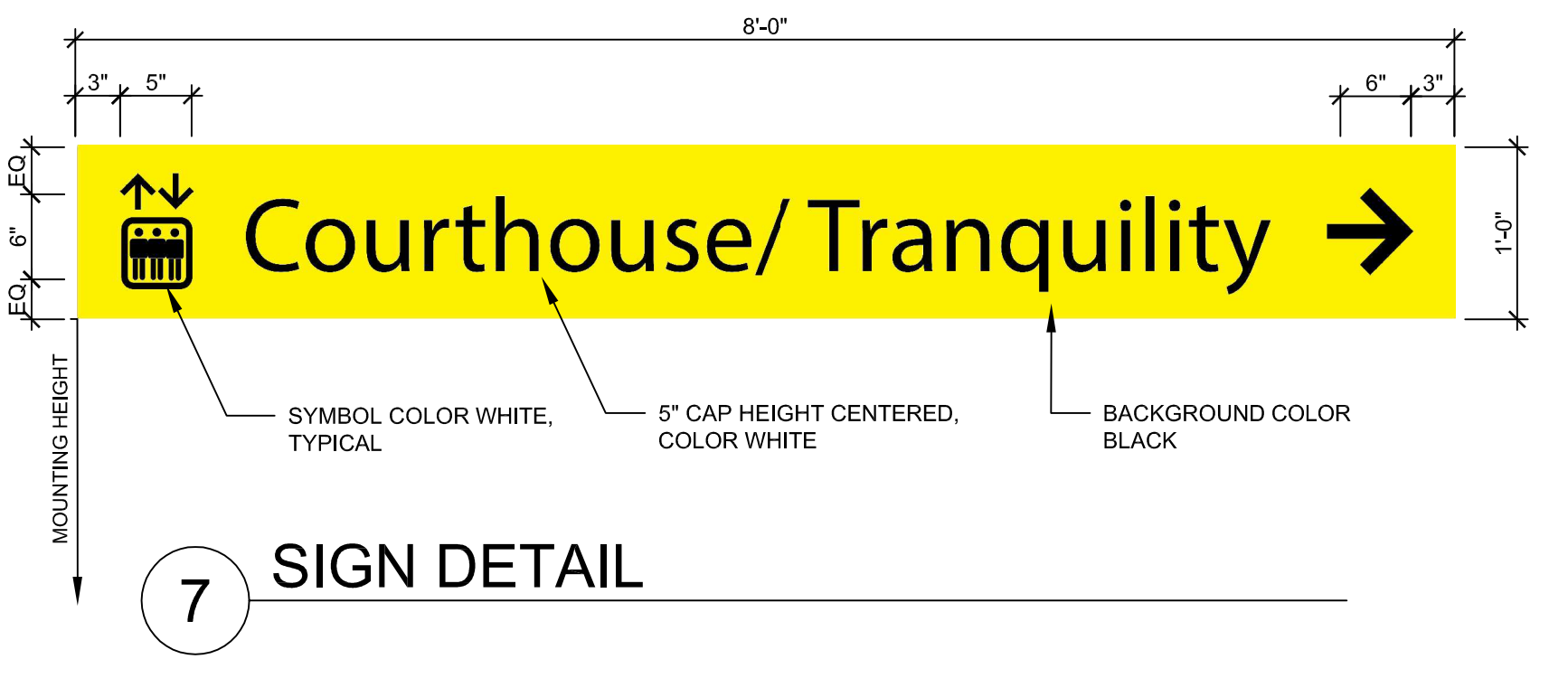

7 SIGN DETAIL

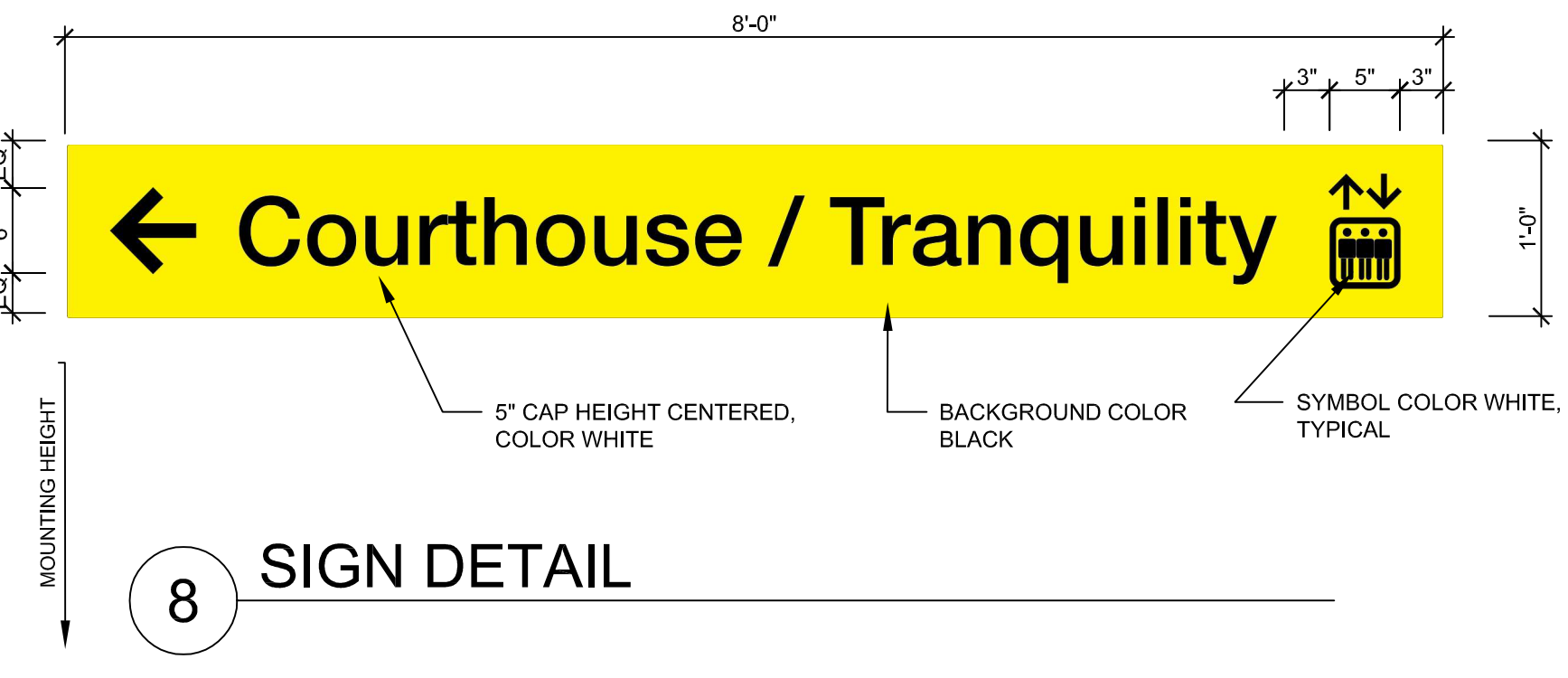

8 SIGN DETAIL

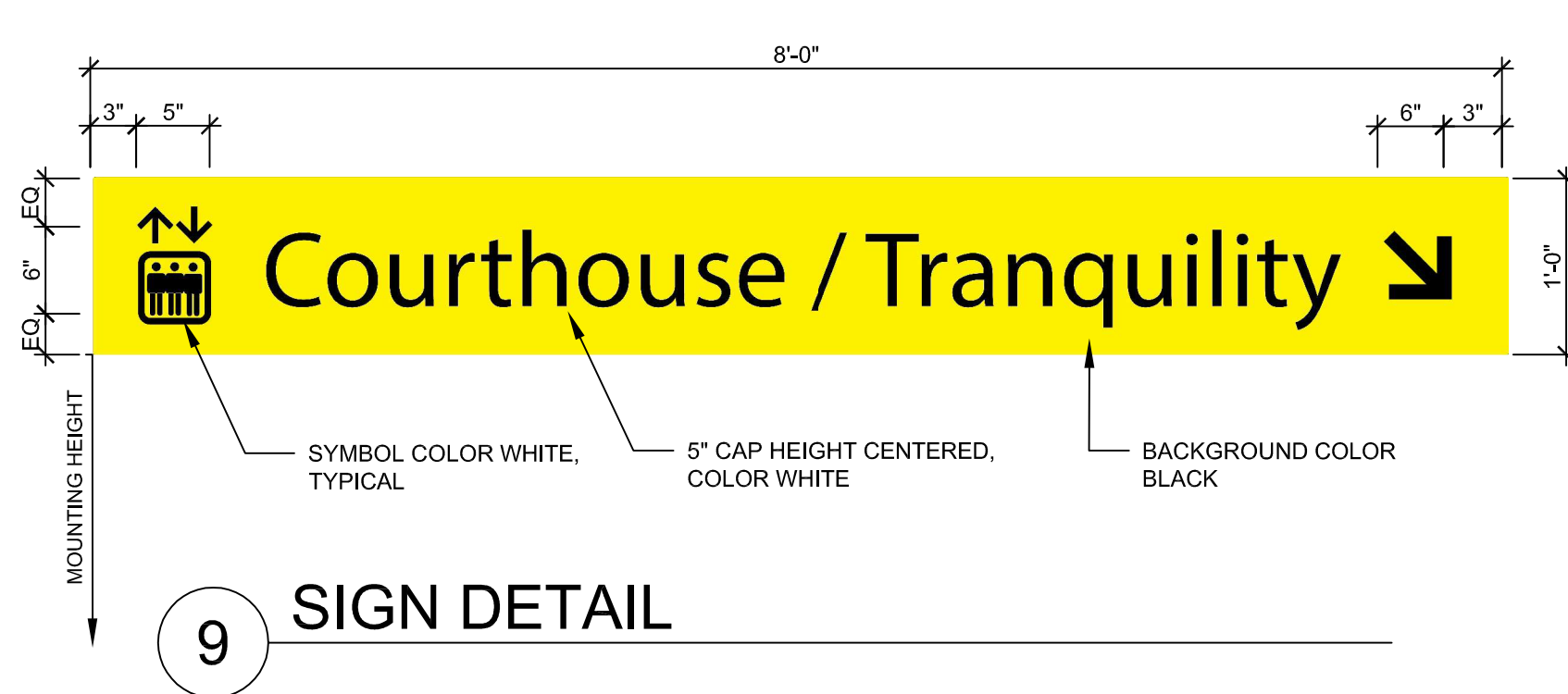

9 SIGN DETAIL

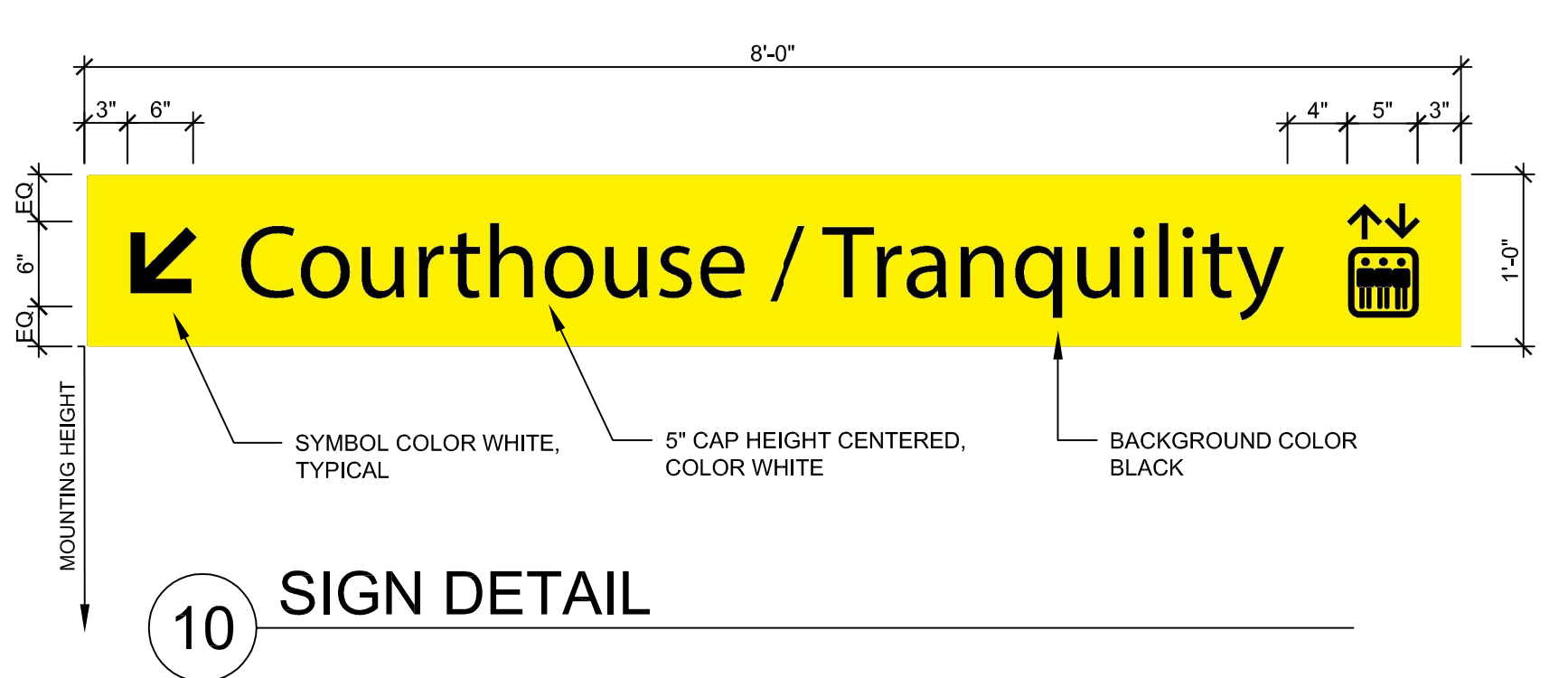

10 SIGN DETAIL

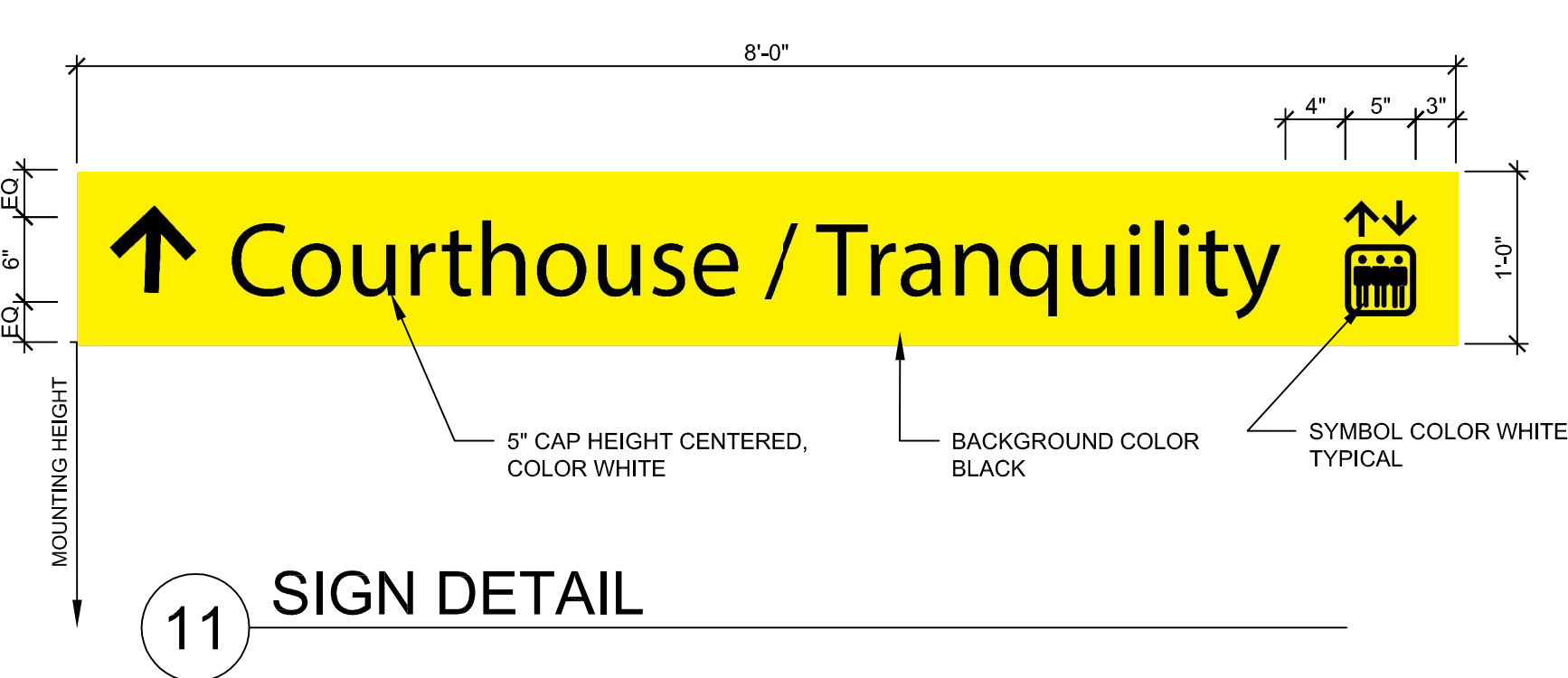

11 SIGN DETAIL

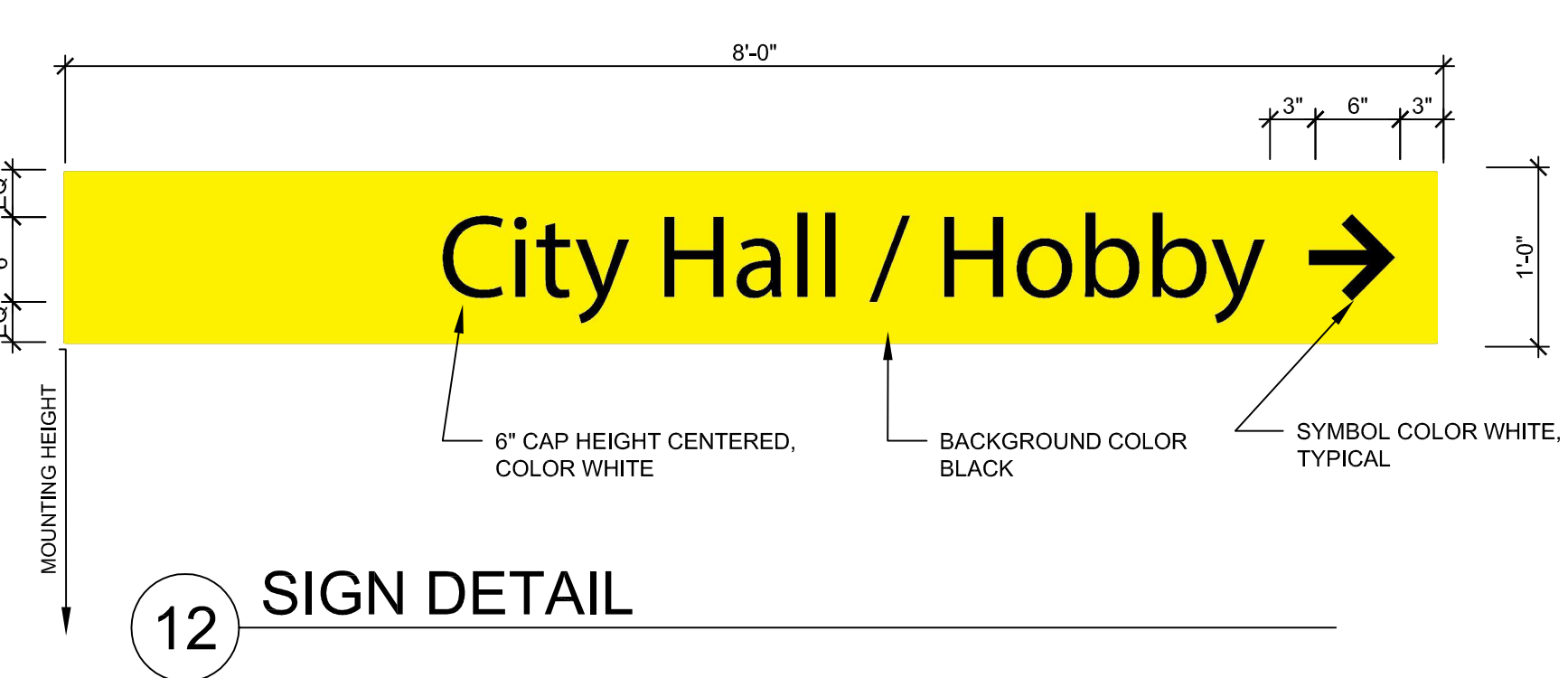

12 SIGN DETAIL

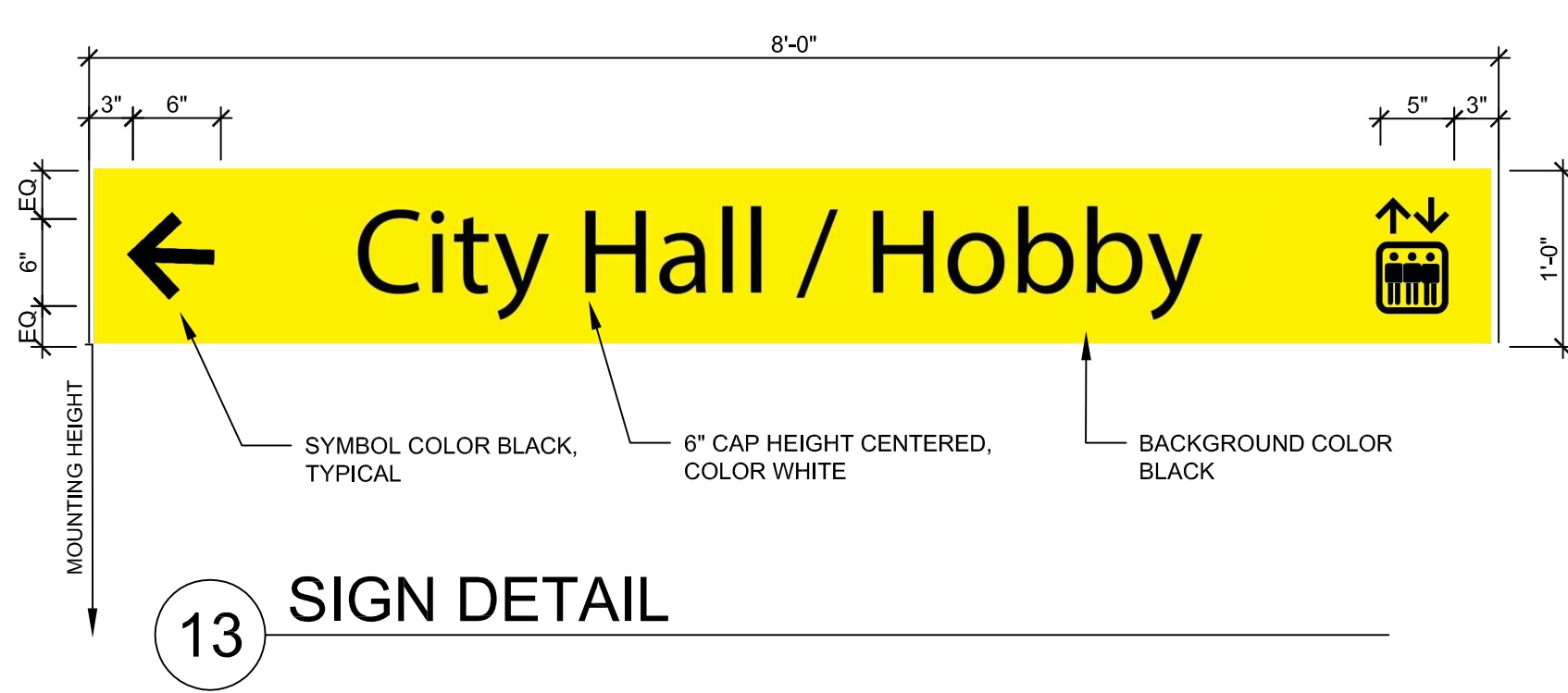

13 SIGN DETAIL

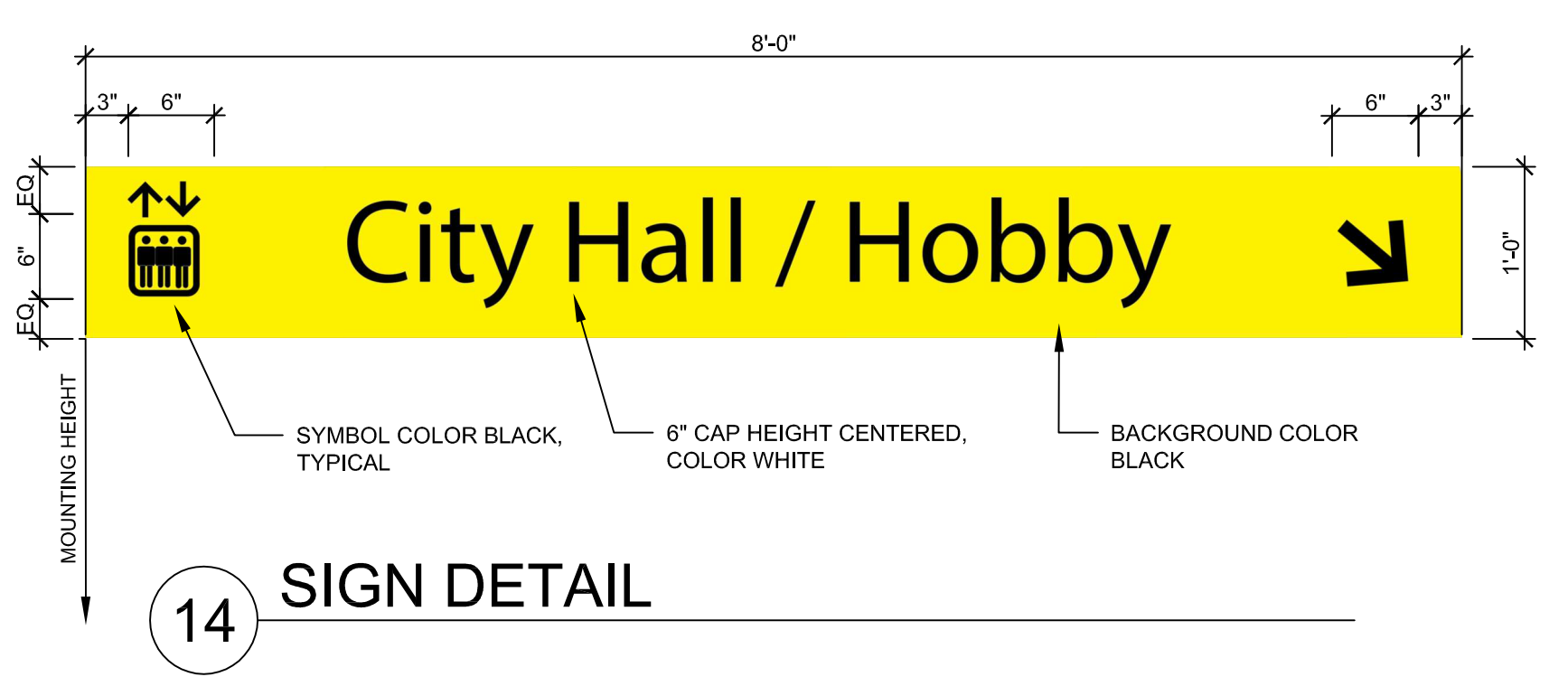

14 SIGN DETAIL

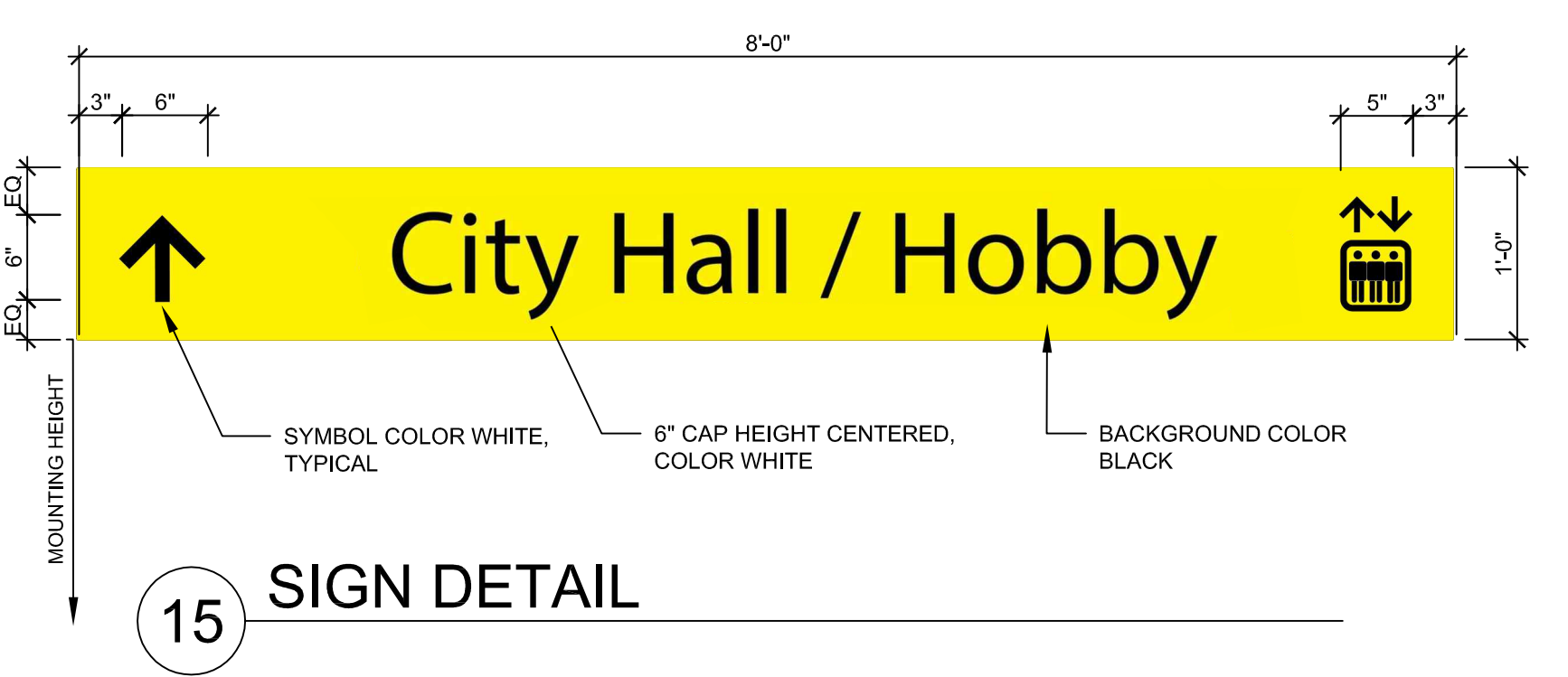

15 SIGN DETAIL

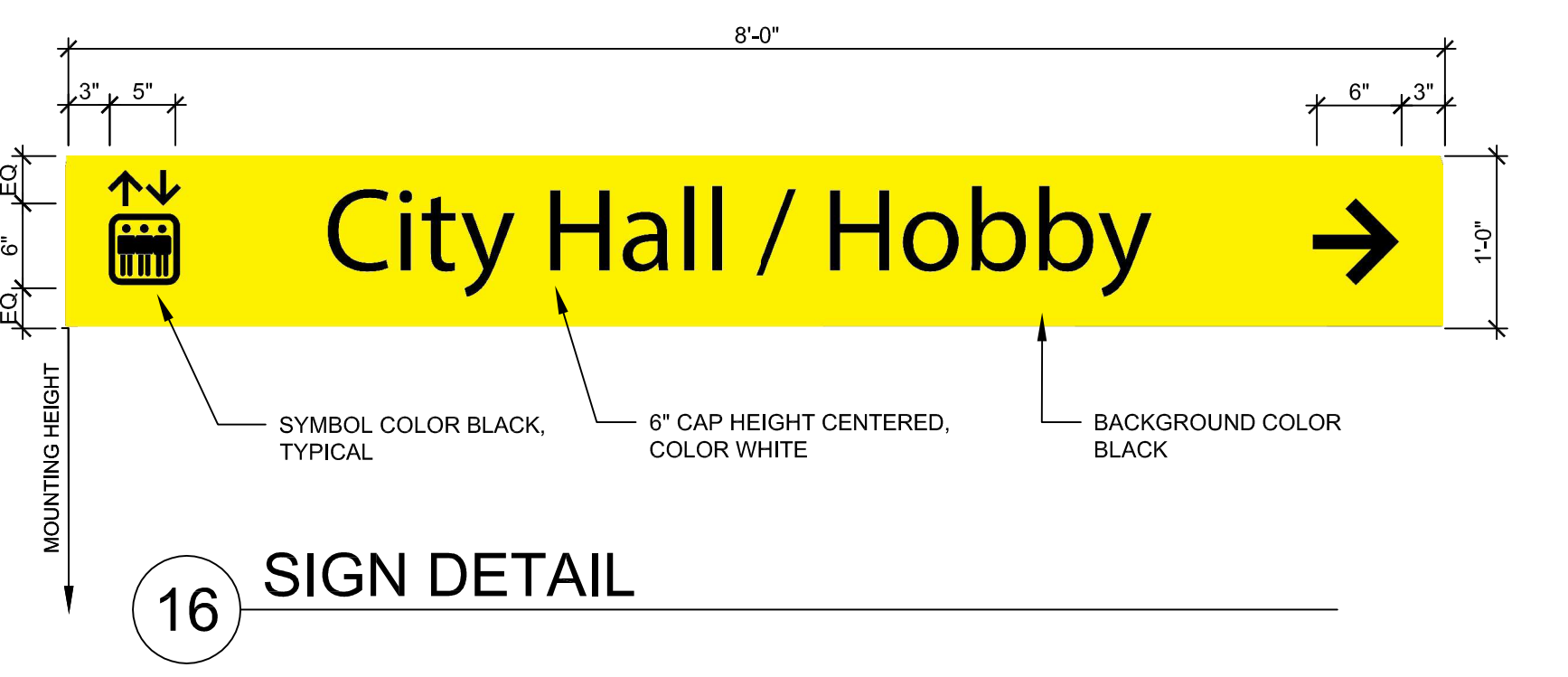

16 SIGN DETAIL

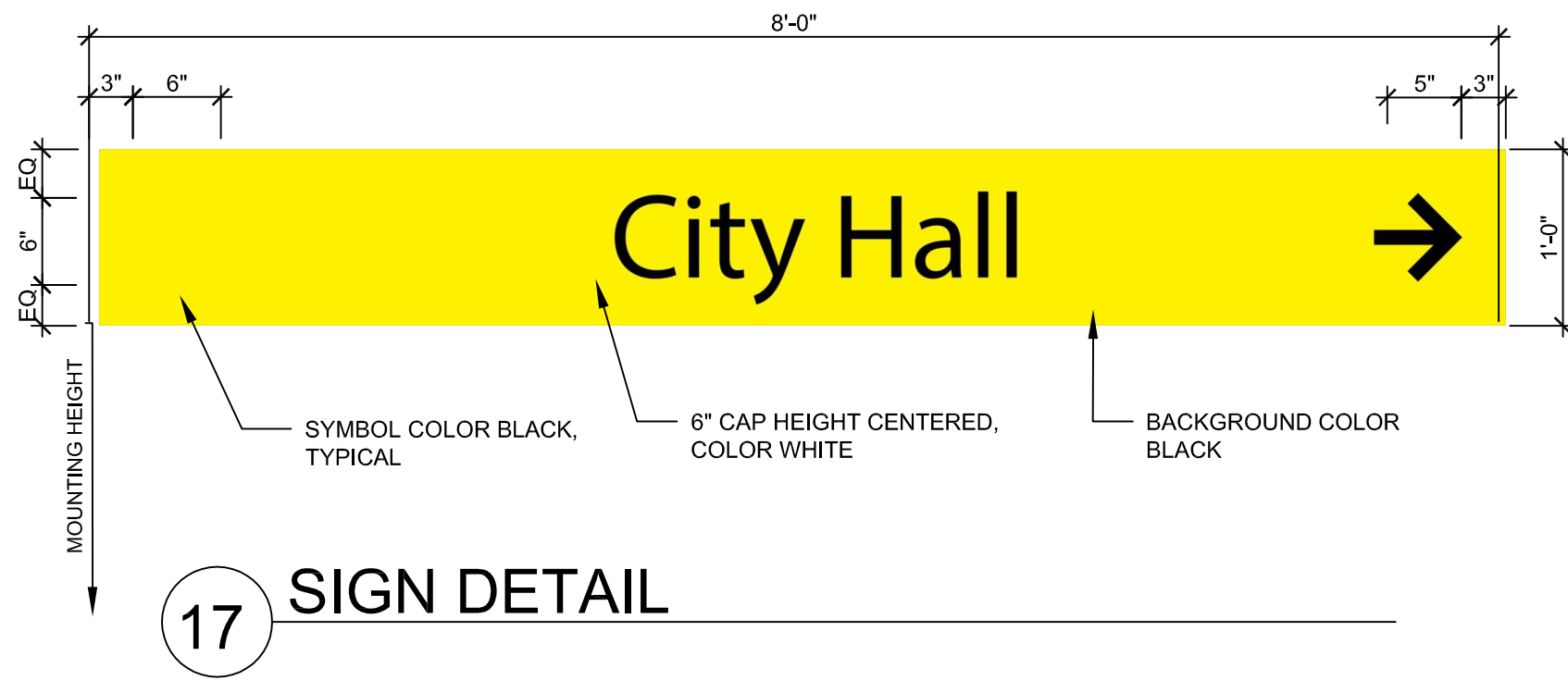

17 SIGN DETAIL

SIGNS ON THIS SHEET ARE TYPE PP (RE: SPECIFICATIONS) UNLESS NOTED OTHERWISE

WALKER
PARKING CONSULTANTS
2525 Bay Area Boulevard
Suite 400
Houston, TX 77058
(281) 280-0058 Ph
(281) 280-0373 Fax
www.walkerparking.com

STATE OF TEXAS
JAMES E. BROOKS
12709
LICENSED PROFESSIONAL ENGINEER
3-23-2014

HOUSTON THEATER DISTRICT
YELLOW GARAGE SIGNAGE
HOUSTON TEXAS

Houstonfirst

PROJECT NO: 25-1883.01		SIGNAGE DETAILS	PK-203
DRAWN BY: RG			
CHECKED BY: BBB			
SHEET TITLE:			
NO.	DATE	DESCRIPTION	
△	5-20-2016	Addendum #1	
	3-24-2016	Construction Documents	
ISSUED:			

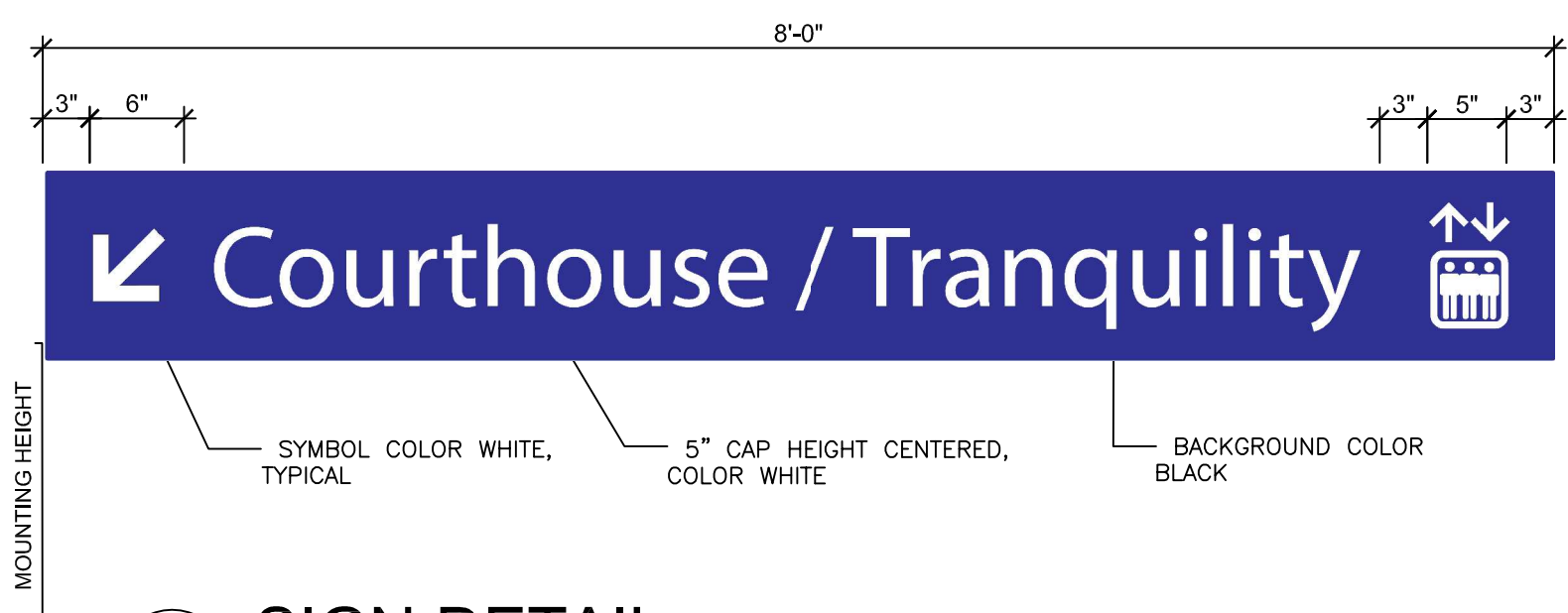

1 SIGN DETAIL

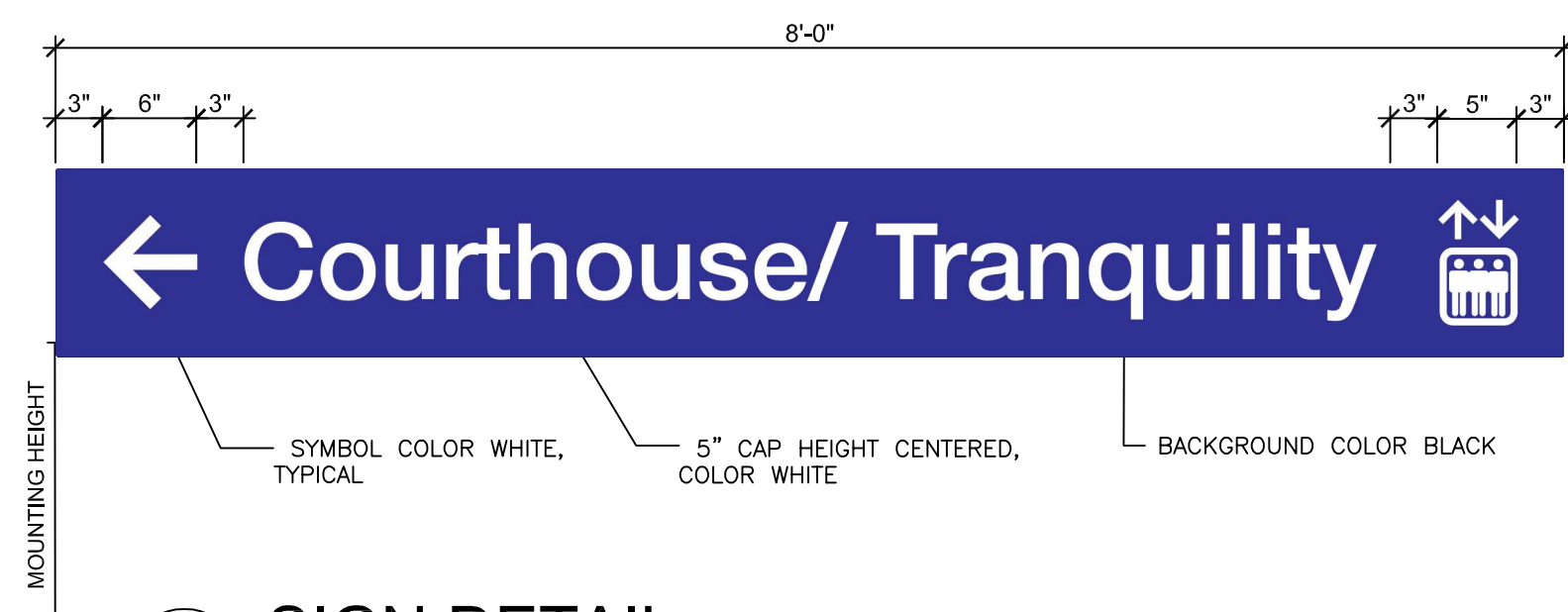

2 SIGN DETAIL

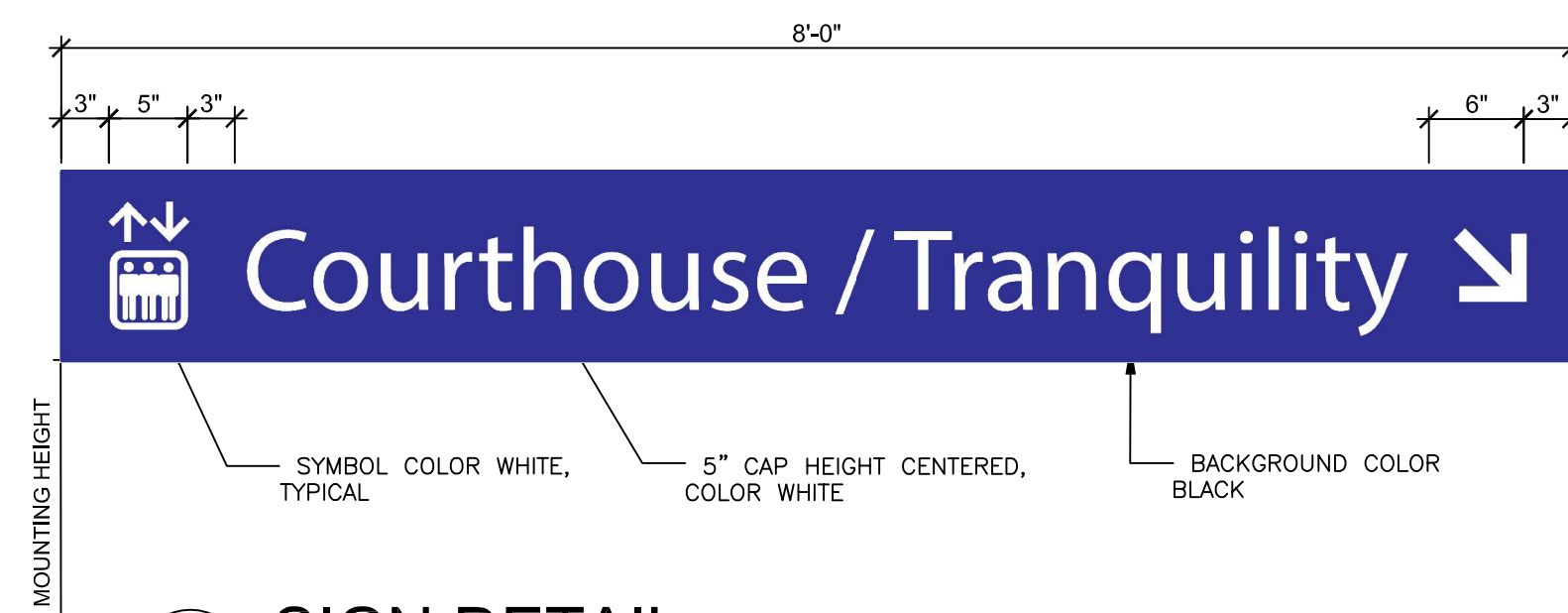

3 SIGN DETAIL

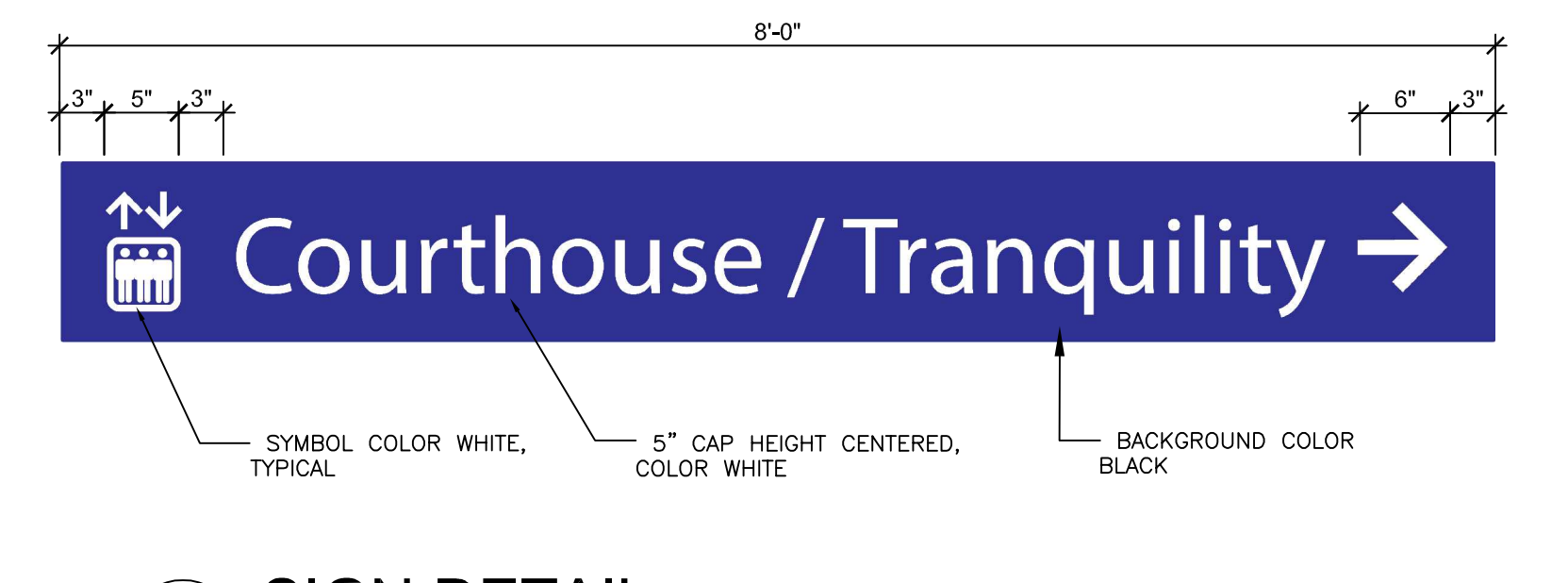

4 SIGN DETAIL

SIGNS ON THIS SHEET ARE TYPE PP (RE: SPECIFICATIONS) UNLESS NOTED OTHERWISE

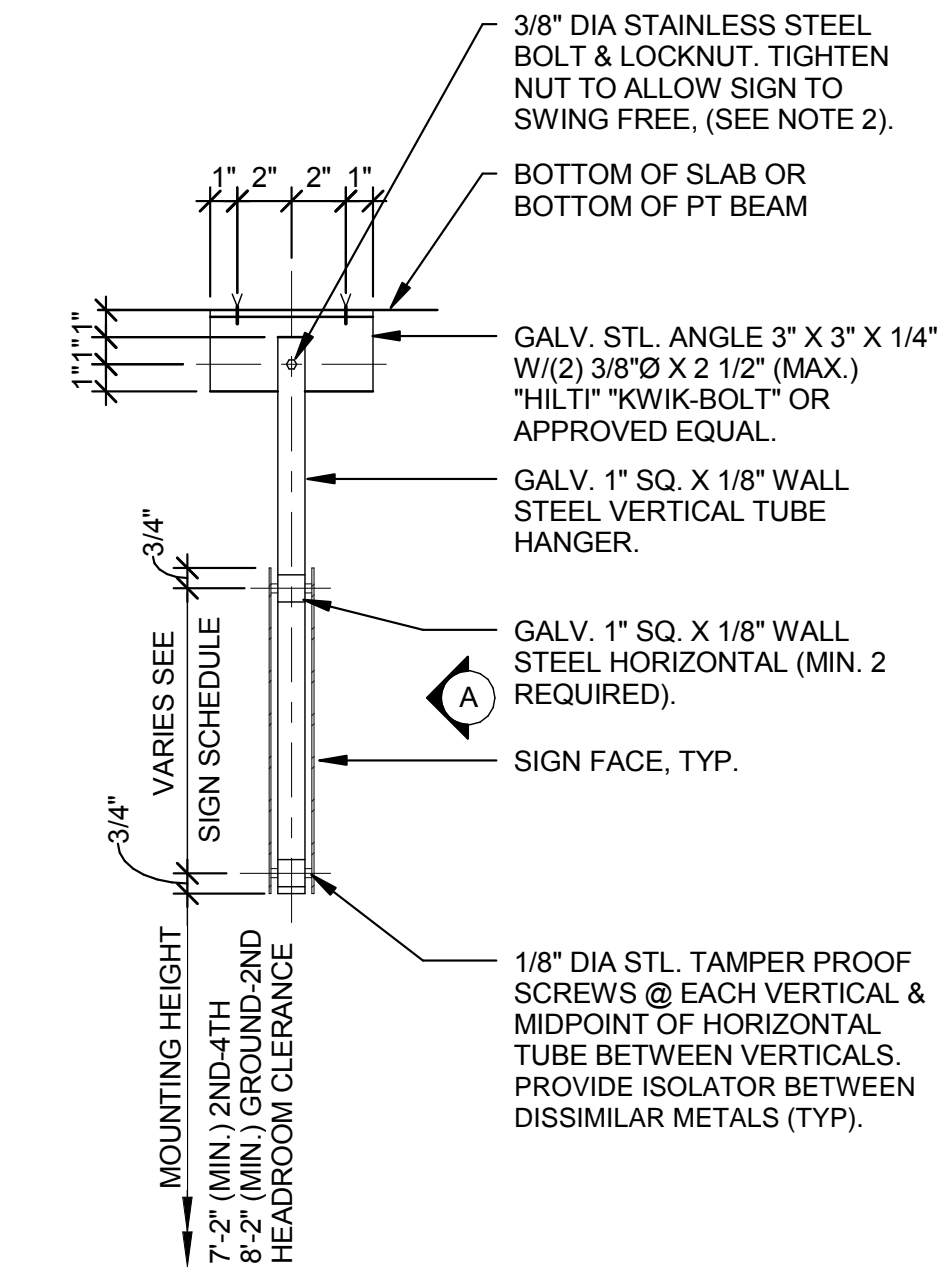

5 SIGN MOUNTING DETAIL

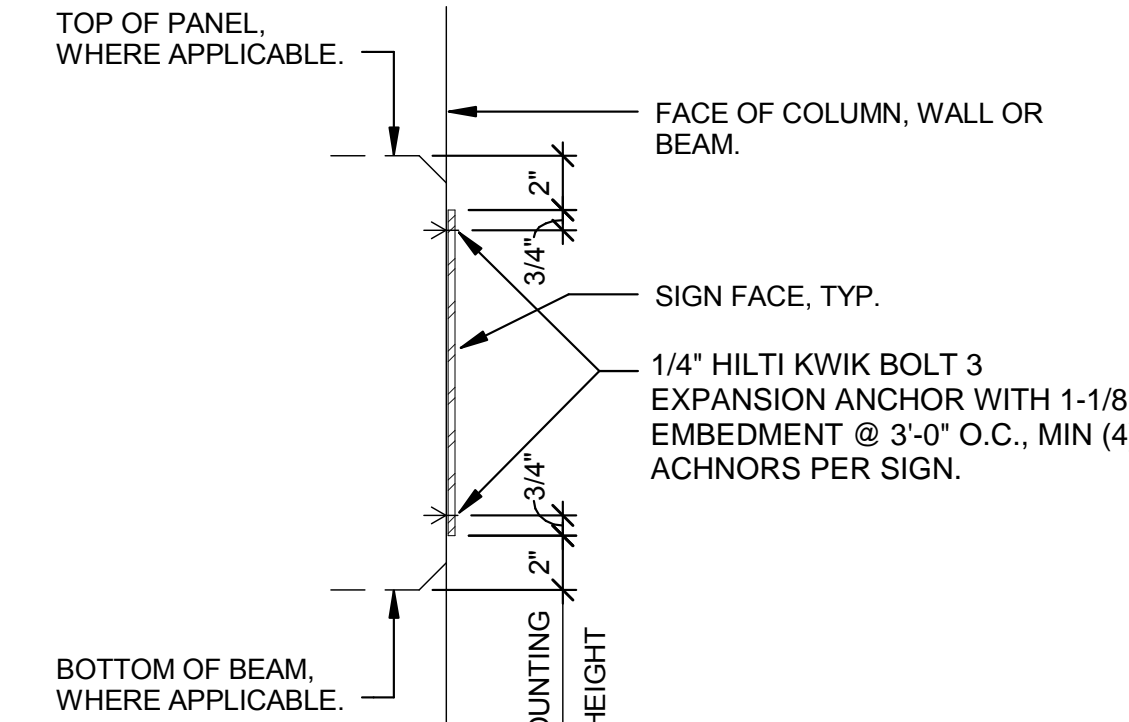
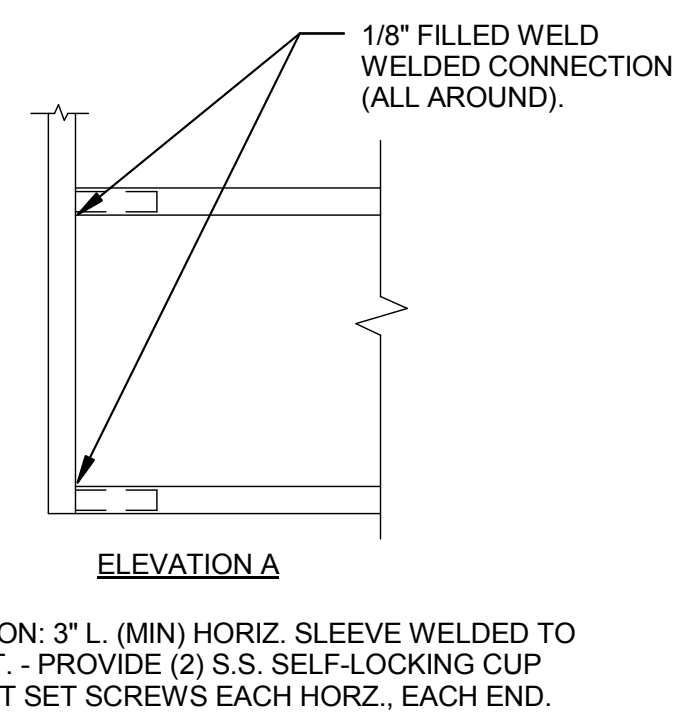

6 SIGN MOUNTING DETAIL

- NOTES:
- HANGER SPACING 3'-0" O.C. MAX. - MIN. (2) HANGERS PER SIGN.
 - OPTIONAL HANGER CONNECTION - 3/8" STAINLESS STEEL CLEVIS PIN W/HAIRPIN COTTER.
 - MAX SIGN CANTILEVER 1'-0".
 - WARNING: SLAB/BEAM MUST BE SCANNED PRIOR TO INSTALLING ALL ANCHORS TO CONFIRM POST TENSION CABLES ARE NOT STRUCK/DAMAGED DURING INSTALLATION.

- CONTRACTOR NOTES:
- DO NOT OVERDRIVE ANCHORS. OVERDRIVEN ANCHORS WILL DAMAGE SIGNS.
 - WHERE TOP OF PANEL OR BOTTOM OF BEAM CONDITION OCCURS; MAINTAIN CONSTANT 2" DIMENSION FROM TOP OF PANEL OR BOTTOM OF BEAM TO SIGN AS SHOWN.
 - WARNING: SLAB/BEAM MUST BE SCANNED PRIOR TO INSTALING ALL ANCHORS TO CONFIRM POST TENSION CABLES ARE NOT STRUCK/DAMAGED DURING INSTALLATION.



HOUSTON THEATER DISTRICT
 BLUE GARAGE SIGNAGE
 HOUSTON TEXAS



NO.	DATE	DESCRIPTION
△	5-20-2016	Addendum #1
	3-24-2016	Construction Documents

PROJECT NO:	25-1883.01
DRAWN BY:	RG
CHECKED BY:	BBB
SHEET TITLE:	SIGNAGE DETAILS

PK-204

J:\25-1883-00-THEATER_DISTRICT_WAYFINDIACAD05-ARCH\PK-204.DWG 3/21/2016 4:23:47 PM SIMON, ANDRE

4'-4"
(FIELD VERIFY)

YOU ARE HERE

Concourse 1 Tunnel

You are on the 2nd Level at Concourse Tunnel. Stairs M, L, K, and J, are located inside

- Jones Hall**
Take the Concourse Tunnel to Jones Hall stair then up to Tunnel Entrance
- Alley Theater**
Take this Concourse Tunnel all the way around to opposite corner of this Garage
- Wortham Center**
Go to Concourse tunnel Door 3 then cross the Garage to opposite side to Wortham Tunnel Entrance
- Bayou Place**
Go to Concourse tunnel Door 3 then cross to Stair/Elevator X at center of Garage
- Downtown Tunnels**
Take this Concourse Tunnel to connect to Downtown Tunnel System
- Courthouse**
Take the Stairs L up to the street level

CT Stair CT Level 1 (CT-1)

"FIELD CONFIRM VINYL DIMENSIONS PRIOR TO FABRICATION"

2'-0"
(FIELD VERIFY)

YOU ARE HERE

Concourse 2 Tunnel

You are on the 2nd Level at Concourse Tunnel. Stairs M, L, K, and J, are located inside

- Jones Hall**
Take the Concourse Tunnel to Jones Hall stair then up to Tunnel Entrance
- Alley Theater**
Take this Concourse Tunnel all the way around to opposite corner of this Garage
- Wortham Center**
Go to Concourse tunnel Door 3 then cross the Garage to opposite side to Wortham Tunnel Entrance
- Bayou Place**
Go to Concourse tunnel Door 3 then cross to Stair/Elevator X at center of Garage
- Downtown Tunnels**
Take the Concourse Tunnel to connect to Downtown Tunnel System
- Courthouse**
Take the Stairs L up to the street level

CT Stair CT Level 2 (CT-2)

YOU ARE HERE

Concourse 3 Tunnel

You are on the 2nd Level at Concourse Tunnel. Stairs M, L, K, and J, are located inside

- Jones Hall**
Take the Concourse Tunnel to Jones Hall stair then up to Tunnel Entrance
- Alley Theater**
Take this Concourse Tunnel all the way around to opposite corner of this Garage
- Wortham Center**
Go across this Garage to opposite side to Wortham Tunnel Entrance
- Bayou Place**
Go to Stair/Elevator X at center of Garage
- Downtown Tunnels**
Take the Concourse Tunnel to connect to Downtown Tunnel System
- Courthouse**
Take the Stairs L up to the street level

CT Stair CT Level 3 (CT-3)

YOU ARE HERE

Concourse 4 Tunnel

You are on the 2nd Level at Concourse Tunnel. Stairs M, L, K, and J, are located inside

- Jones Hall**
Take the Concourse Tunnel to Jones Hall stair then up to Tunnel Entrance
- Alley Theater**
Take this Concourse Tunnel all the way around to opposite corner of this Garage
- Wortham Center**
Go to Concourse tunnel Door 3 then cross the Garage to opposite side to Wortham Tunnel Entrance
- Bayou Place**
Go to Concourse tunnel Door 3 then cross to Stair/Elevator X at center of Garage
- Downtown Tunnel**
Take this Concourse Tunnel to connect to Downtown Tunnel System
- Courthouse**
Take the Stairs L up to the street level

CT Stair CT Level 4 (CT-4)

YOU ARE HERE

Concourse 5 Tunnel

You are on the 2nd Level at Concourse Tunnel. Stairs M, L, K, and J, are located inside

- Jones Hall**
Take the Concourse Tunnel to Jones Hall stair then up to Tunnel Entrance
- Alley Theatre**
Take this Concourse Tunnel all the way around to opposite corner of this Garage
- Wortham Center**
Go to Concourse tunnel Door 3 then cross the Garage to opposite side to Wortham Tunnel Entrance
- Bayou Place**
Go to Concourse tunnel Door 3 then cross to Stair/Elevator X at center of Garage
- Downtown Tunnel**
Take this Concourse Tunnel to connect to Downtown Tunnel System
- Courthouse**
Take the Stairs L up to the street level

CT Stair CT Level 5 (CT-5)

YOU ARE HERE

Concourse 6 Tunnel

You are on the 2nd Level at Concourse Tunnel. Stairs M, L, K, and J, are located inside

- Jones Hall**
Take the Concourse Tunnel to Jones Hall stair then up to Tunnel Entrance
- Alley Theater**
Take this Concourse Tunnel all the way around to opposite corner of this Garage
- Wortham Center**
Go to Concourse tunnel Door 3 then cross the Garage to opposite side to Wortham Tunnel Entrance
- Bayou Place**
Go to Concourse tunnel Door 3 then cross to Stair/Elevator X at center of Garage
- Downtown Tunnel**
Take this Concourse Tunnel to connect to Downtown Tunnel System
- Courthouse**
Take the Stairs L up to the street level

CT Stair CT Level 6 (CT-6)

ALL DETAILS ON PK-200 REPRESENT VINYL OVERLAY TO BE FABRICATED AND INSTALLED PERMANENTLY ON EXISTING SUBSTRATES. REMOVE EXISTING VINYL SIGN (PEEL OFF) PRIOR TO INSTALLATION OF NEW. PROVIDE MIN 8.5"x11" SHOP DRAWING OF EACH INDIVIDUAL VINYL OVERLAY FOR OWNER REVIEW PRIOR TO PROCUREMENT.

J:\25-1883-00-THEATER_DISTRICT_WAYFINDIACAD05-ARCH\PK-206.DWG 3/21/2016 4:22:38 PM SIMON, ANDRE

WALKER
PARKING CONSULTANTS
2525 Bay Area Boulevard
Suite 400
Houston, TX 77058
(281) 280-0658 Ph
(281) 280-0373 Fax
www.walkerparking.com

STATE OF TEXAS
JAMES E. BROOKS
12709
LICENSED PROFESSIONAL ENGINEER
3-23-2016

HOUSTON THEATER DISTRICT
YELLOW GARAGE SIGNAGE
HOUSTON TEXAS

Houstonfirst

PROJECT NO:	25-1883.01	
DRAWN BY:	RG	
CHECKED BY:	BBB	
SHEET TITLE:	SIGNAGE DETAILS	
NO.	DATE	DESCRIPTION
5-20-2016		Addendum #1
3-24-2016		Construction Documents
ISSUED:		

PROJECT NO:	25-1883.01
DRAWN BY:	RG
CHECKED BY:	BBB
SHEET TITLE:	SIGNAGE DETAILS
PK-206	

Stair A

A

YOU ARE HERE

You are on the 1st Level at Stair A. This Elevator/Stair exits near Rusk Street

Courthouse Tranquility Park
Take The Elevator/Stair up to (G) Street Level

Hobby Center City Hall
Cross Ramp into Yellow Garage and tunnel entrance is on the 1st level take the Elevator/Stair up to Street Level

Alley Theatre Jones Hall Wortham Center Downtown Tunnels Bayou Place
Walk to stairs or ramp, go down to tunnel the follow sign there

Stair A

A

YOU ARE HERE

You are on the 2nd Level at Stair A. This Elevator/Stair exits near Rusk Street

Courthouse Tranquility Park
Take The Elevator/Stair up to Street Level

Hobby Center City Hall
Cross Ramp into Yellow Garage and tunnel entrance is on the 1st Level or take the Elevator/Stair up to Street Level

Alley Theatre Jones Hall Wortham Center Downtown Tunnels Bayou Place
Take Elevator/Stair to 1st Level (P1) and then Follow signs

Stair A

A

YOU ARE HERE

You are on the 3rd Level at Stair A. This Elevator/Stair exits near Rusk Street

Courthouse Tranquility Park
Take The Elevator/Stair up to (G) Street Level

Hobby Center City Hall
Cross Ramp into Yellow Garage and tunnel entrance is on the 1st Level or take the Elevator/Stair up to Street Level

Alley Theatre Jones Hall Wortham Center Downtown Tunnels Bayou Place
Take Elevator/Stair to (P1) 1st Level and then Follow signs

Stair B

B

YOU ARE HERE

You are on the 1st Level at Stair B. This Elevator/Stair exits on Capital Street

Tranquility Park
Take The Stair up to Street Level

Courthouse
Take Elevator/Stair at Stair A up to Street Level

Hobby Center City Hall
Cross Ramp into Yellow Garage and tunnel entrance is on the 1st Level Garage or take the Elevator/Stair up to Street Level

Alley Theatre Downtown Tunnels Jones Hall Wortham Center Bayou Place
Walk to Stairs at ramp, then go to Concourse Tunnel then follow signs there

Stair B

B

YOU ARE HERE

You are on the 1st Level at Stair B. This Elevator/Stair exits on Capital Street

Tranquility Park
Take The Stair up to Street Level

Courthouse
Take Elevator/Stair at Stair A up to Street Level

Hobby Center City Hall
Cross Ramp into Yellow Garage and tunnel entrance is on the 1st Level Garage or take the Elevator/Stair up to Street Level

Alley Theatre Downtown Tunnels Jones Hall Wortham Center Bayou Place
Walk to Stairs at ramp, then go to Concourse Tunnel then follow signs there

Stair B

B

YOU ARE HERE

You are on the 3rd Level at Stair B. This Elevator/Stair exits on Capital

Tranquility Park
Take The Stair up to Street Level

Courthouse
Take Elevator/Stair at Stair A up to Street Level

Hobby Center City Hall
Cross Ramp into Yellow Garage and tunnel entrance is on the 1st Level or take the Elevator/Stair up to Street Level

Alley Theatre Downtown Tunnels Jones Hall Wortham Center Bayou Place
Take the Stairs up to the 1st Level then follow signs there

A Stair A Level 1 (A-1)

A Stair A Level 2 (A-2)

A Stair A Level 3 (A-3)

B Stair B Level 1 (B-1)

B Stair B Level 2 (B-2)

B Stair B Level 3 (B-3)

Stair C

C

YOU ARE HERE

You are on the 1st Level at Stair C. This Stair exits on Rusk Street at Bagby Street

Tranquility Park
Take The Stair up to Street Level

Courthouse
Take Elevator/Stair at Stair A up to Street Level

Hobby Center City Hall
Take the Stair to the 1st Level then follow signs to tunnel entrance across Yellow Garage or up to Street Level

Stair C

C

YOU ARE HERE

You are on the 2nd Level at Stair C. This Stair exits on Rusk Street at Bagby Street

Tranquility Park
Take The Stair up to Street Level

Courthouse
Take Elevator/Stair at Stair A up to Street Level

Hobby Center City Hall
Take the Stair to the 1st Level then follow signs to tunnel entrance across Yellow Garage or up to Street Level

Stair C

C

YOU ARE HERE

You are on the 3rd Level at Stair C. This Stair exits on Rusk Street at Bagby Street

Tranquility Park
Take The Stair up to Street Level

Courthouse
Take Elevator/Stair at Stair A up to Street Level

Hobby Center City Hall
Take the Stair to the 1st Level then follow signs to tunnel entrance across Yellow Garage or up to Street Level

Stair C

C

YOU ARE HERE

You are on the 1st Level at Stair C. This Stair exits on Rusk Street at Bagby Street

METRORail Tranquility Park Courthouse Bayou Place
Take The Stair up to Street Level

Hobby Center City Hall
Cross this Garage to tunnel entrances on this Level

Stair C

C

YOU ARE HERE

You are on the 2nd Level at Stair C. This Stair exits on Rusk Street at Bagby Street

METRORail Tranquility Park Courthouse Bayou Place
Take The Stair up to Street Level

Hobby Center City Hall
Take this stair to the 1st Level then follow signs to tunnel entrances

Stair C

C

YOU ARE HERE

You are on the 3rd Level at Stair C. This Stair exits on Rusk Street at Bagby Street

METRORail Tranquility Park Courthouse Bayou Place
Take The Stair up to Street Level

Hobby Center City Hall
Take this stair to the 1st Level then follow signs to tunnel entrances

C Stair C Level 1 (C-1)

C Stair C Level 2 (C-2)

C Stair C Level 3 (C-3)

C Stair C Level 3 (C-3)

C Stair C Level 3 (C-3)

C Stair C Level 3 (C-3)

"FIELD CONFIRM VINYL DIMENSIONS PRIOR TO FABRICATION"

J:\25-1883-00-THEATER_DISTRICT_WAYFINDING\05-ARCH\PK-207.DWG 3/24/2016 12:01:01 PM SIMON, ANDRE

WALKER
PARKING CONSULTANTS

2525 Bay Area Boulevard
Suite 400
Houston, TX 77058
(281) 280-0658 Pn
(281) 280-0373 Fax
www.walkerparking.com

Walker Parking Consultants/Engineers, Inc.
Firm Certificate of Authority Number: F-004168

STATE OF TEXAS
JAMES E. BROOKS
12709
LICENSED PROFESSIONAL ENGINEER
3-23-2016

HOUSTON THEATER DISTRICT
YELLOW GARAGE SIGNAGE

HOUSTON TEXAS

Houstonfirst

PROJECT NO:	25-1883.01	
DRAWN BY:	RG	
CHECKED BY:	BBB	
SHEET TITLE:	SIGNAGE DETAILS	
NO.	DATE	DESCRIPTION
Δ	5-20-2016	Addendum #1
	3-24-2016	Construction Documents
ISSUED:		

PK-207



D Stair D Level 1 (D-1)



D Stair D Level 2 (D-2)



D Stair D Level 3 (D-3)

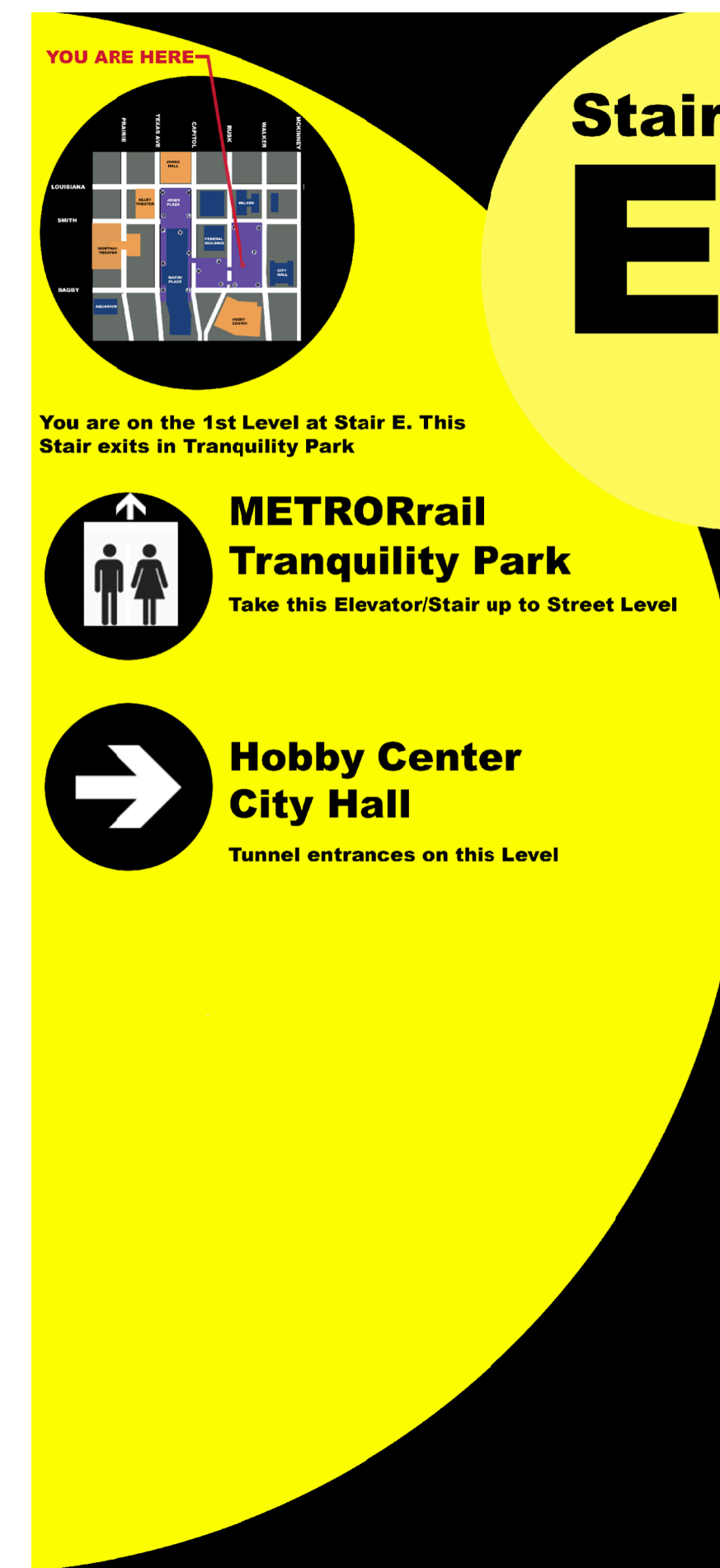

E Stair E Level 1 (E-1)



E Stair E Level 2 (E-2)



E Stair E Level 3 (E-3)



F Stair F Level 1 (F-1)



F Stair F Level 2 (F-2)

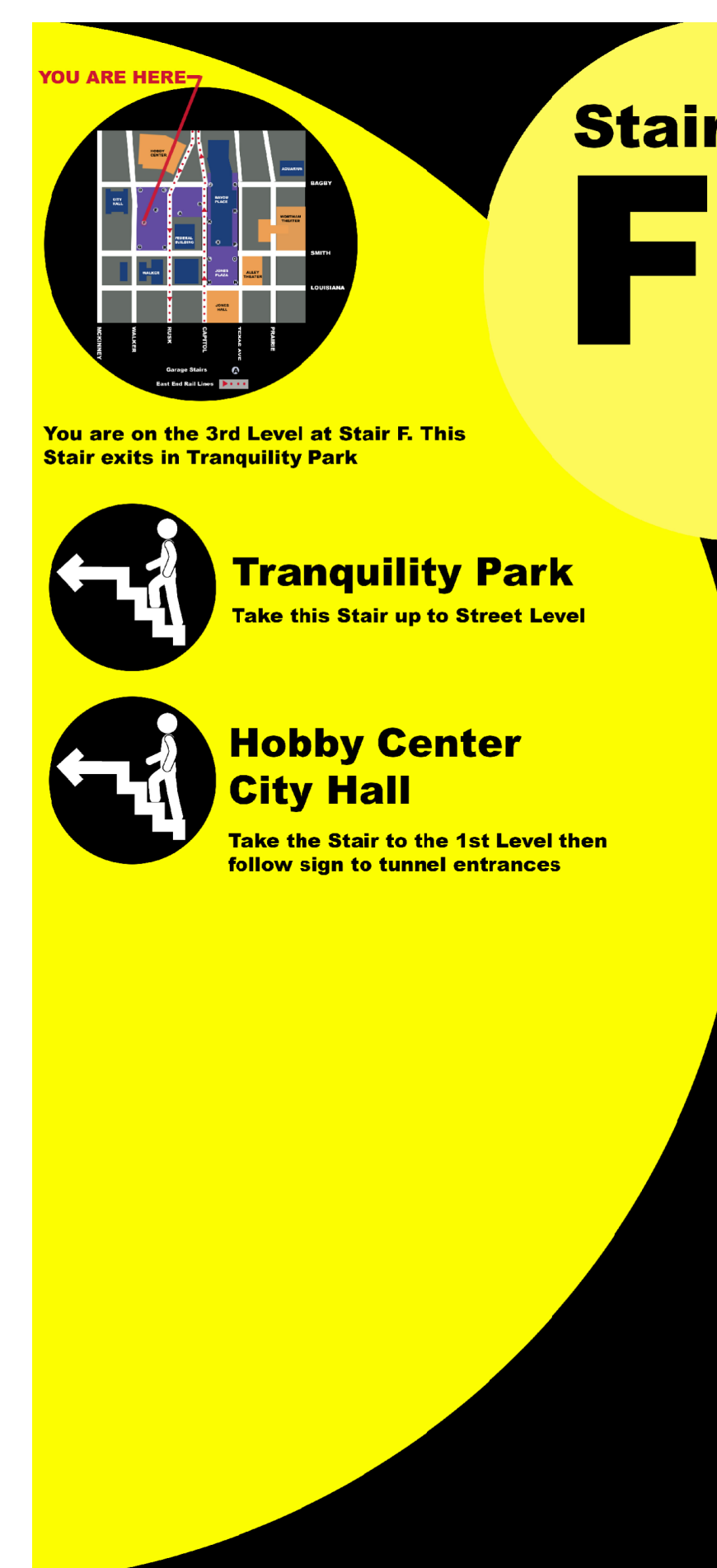

F Stair F Level 3 (F-3)

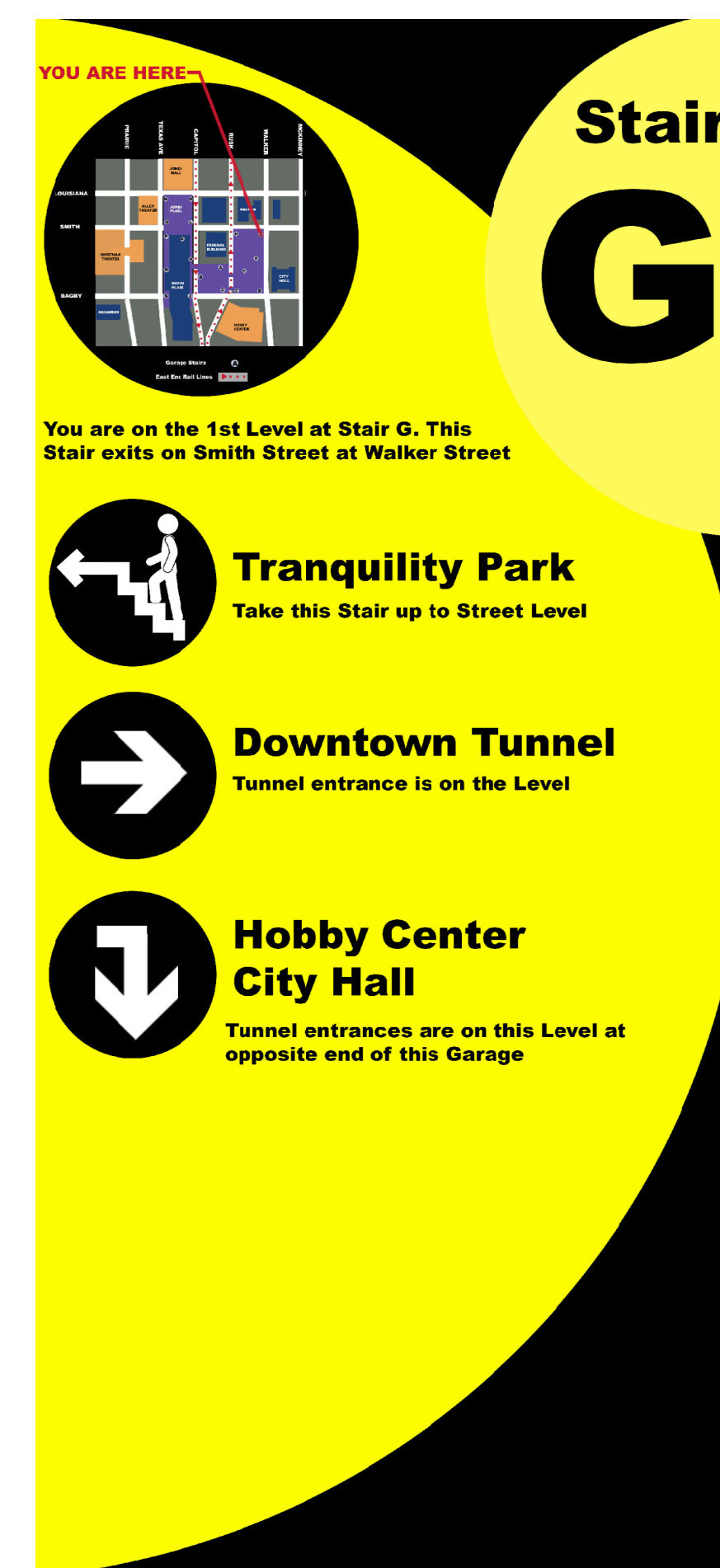

G Stair G Level 3 (G-1)



G Stair G Level 2 (G-2)



G Stair G Level 3 (G-3)

"FIELD CONFIRM VINYL DIMENSIONS PRIOR TO FABRICATION"

J:\25-1883-00-THEATER_DISTRICT_WAYFINDING\05-ARCH\PK-208.DWG 3/7/2016 5:33:27 PM SIMON, ANDRE



HOUSTON THEATER DISTRICT
YELLOW GARAGE SIGNAGE
HOUSTON TEXAS



PROJECT NO:	25-1883.01	
DRAWN BY:	RG	
CHECKED BY:	BBB	
SHEET TITLE:	SIGNAGE DETAILS	
NO.	DATE	DESCRIPTION
Δ	5-20-2016	Addendum #1
	3-24-2016	Construction Documents
ISSUED:		

SIGNAGE
DETAILS

PK-208

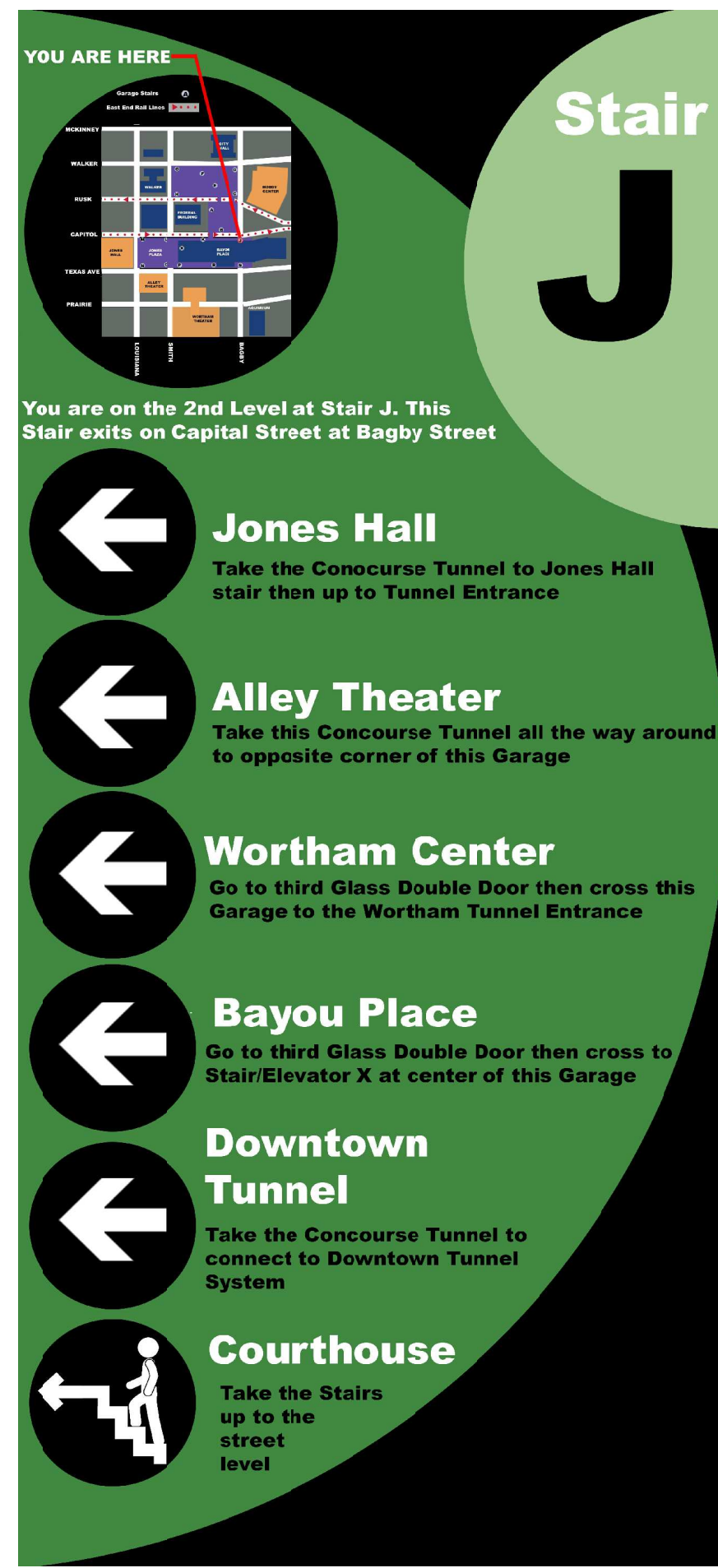
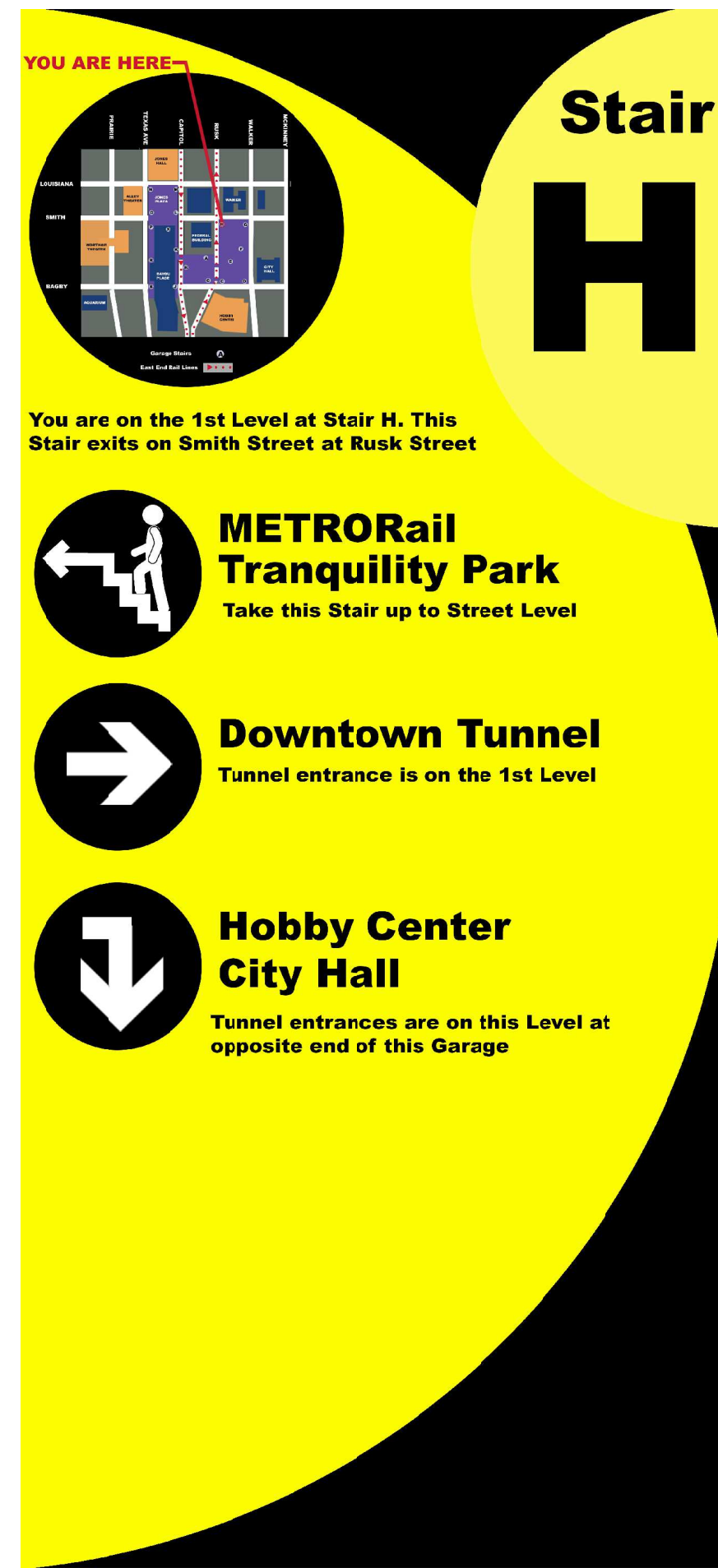

H Stair H Level 1 (H-1)

H Stair H Level 2 (H-2)

H Stair H Level 3 (H-3)

J Stair J Level 1 (J-1)

J Stair J Level 2 (J-2)

J Stair J Level 3 (J-3)

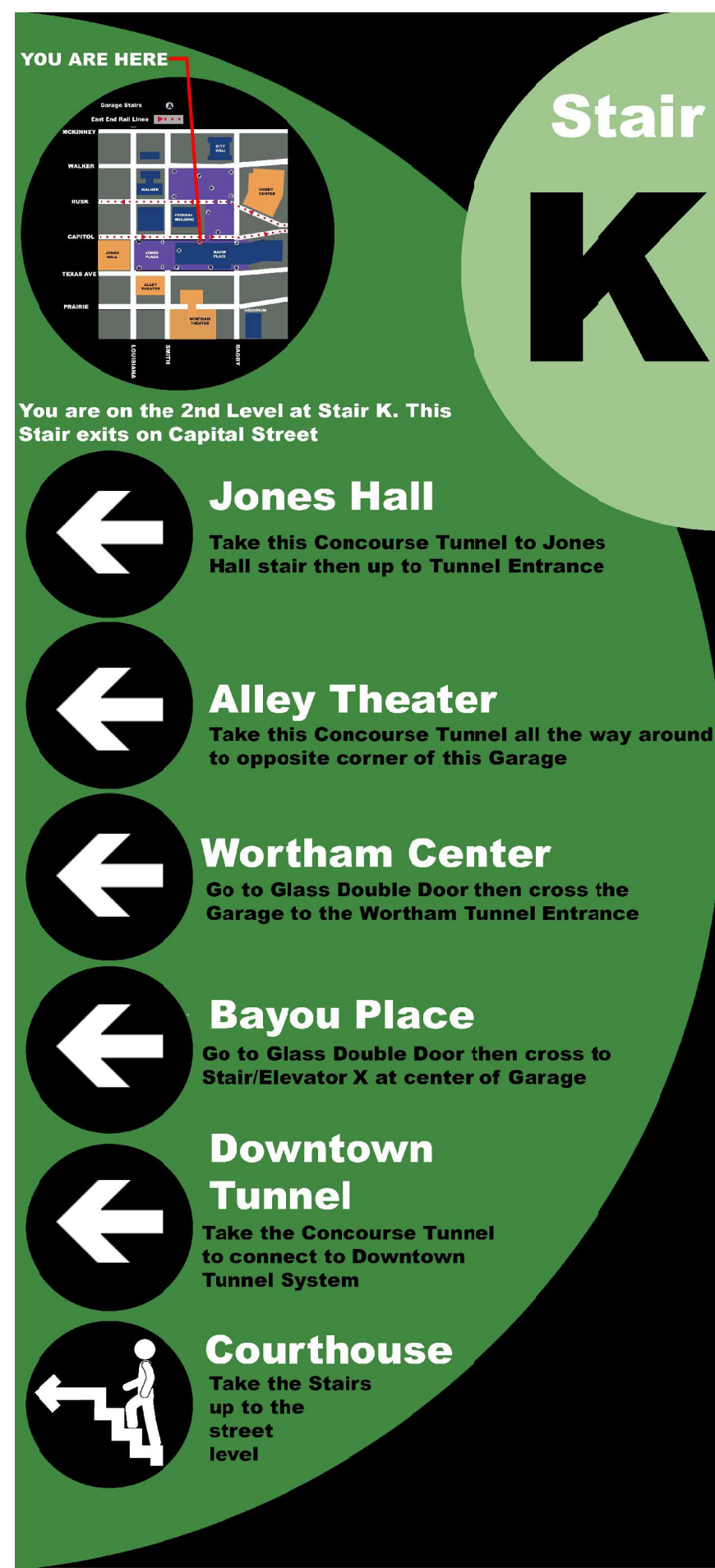
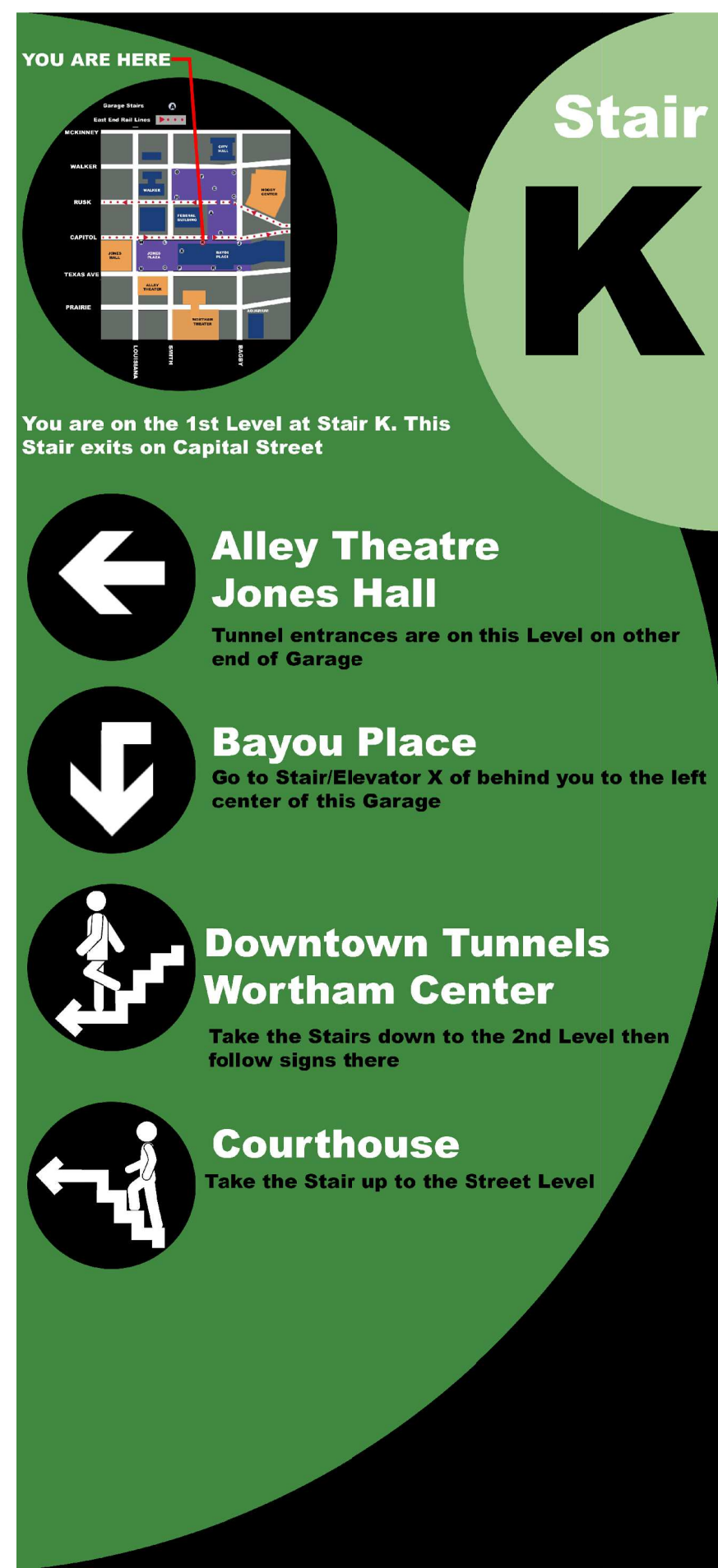

K Stair K Level 1 (K-1)

K Stair K Level 2 (K-2)

K Stair K Level 3 (K-3)

L Stair L Level 3 (L-1)

L Stair L Level 2 (L-2)

L Stair L Level 3 (L-3)

"FIELD CONFIRM VINYL DIMENSIONS PRIOR TO FABRICATION"

J:\25-1883-00-THEATER_DISTRICT_WAYFINDING\05-ARCH\PK-209.DWG 3/21/2016 4:23:30 PM SIMON, ANDRE

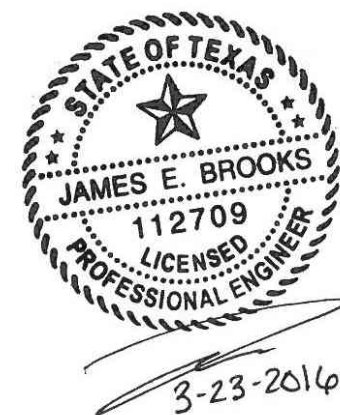

HOUSTON THEATER DISTRICT
YELLOW GARAGE SIGNAGE
HOUSTON TEXAS



PROJECT NO:	25-1883.01	
DRAWN BY:	RG	
CHECKED BY:	BBB	
SHEET TITLE:	SIGNAGE DETAILS	
NO.	DATE	DESCRIPTION
5-20-2016		Addendum #1
3-24-2016		Construction Documents
ISSUED:		

PK-209



M Stair M Level 1 (M-1)

M Stair M Level 2 (M-2)

M Stair M Level 3 (M-3)

N Stair N Level 1 (N-1)

N Stair N Level 2 (N-2)

N Stair N Level 3 (N-3)

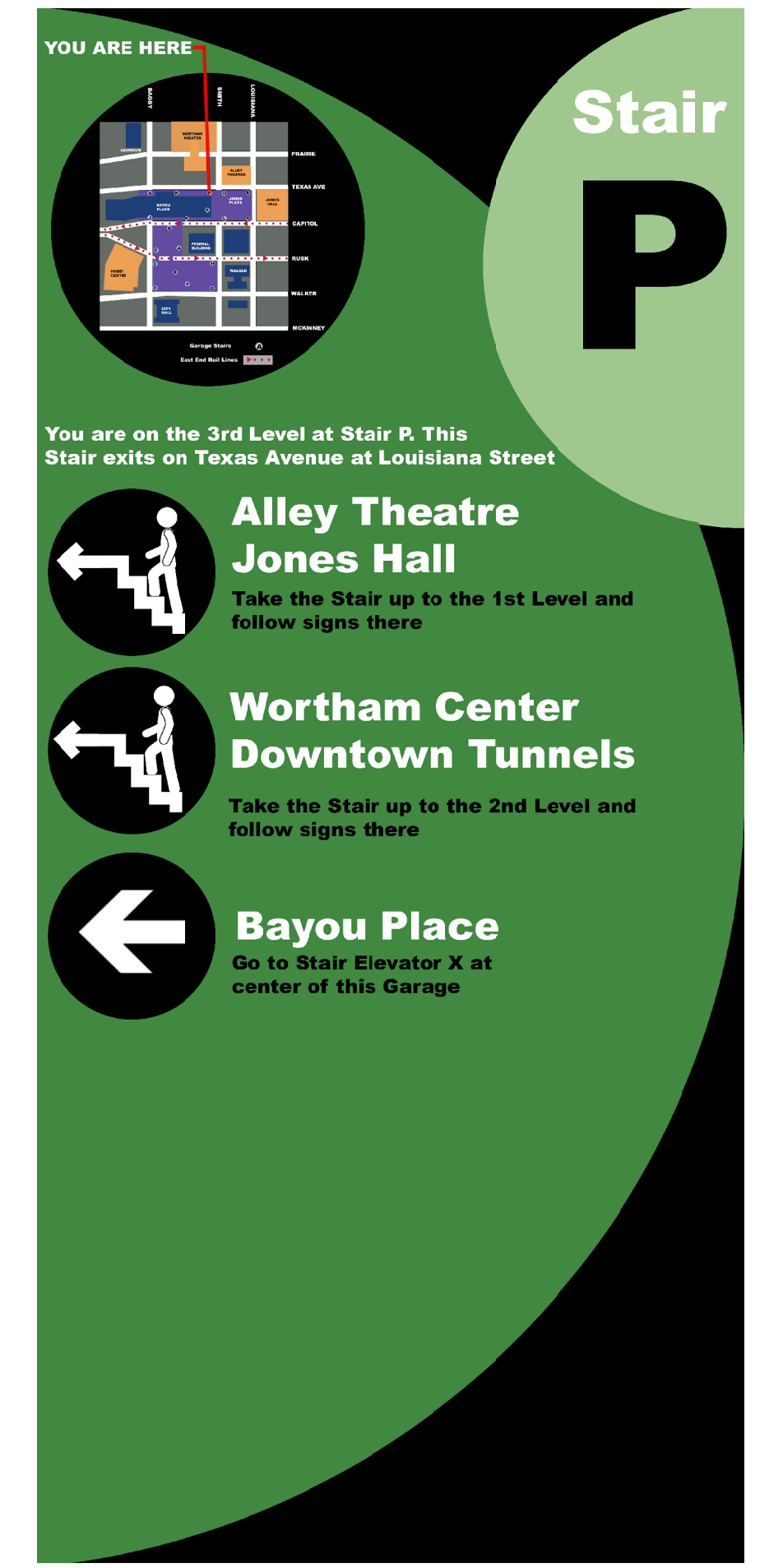
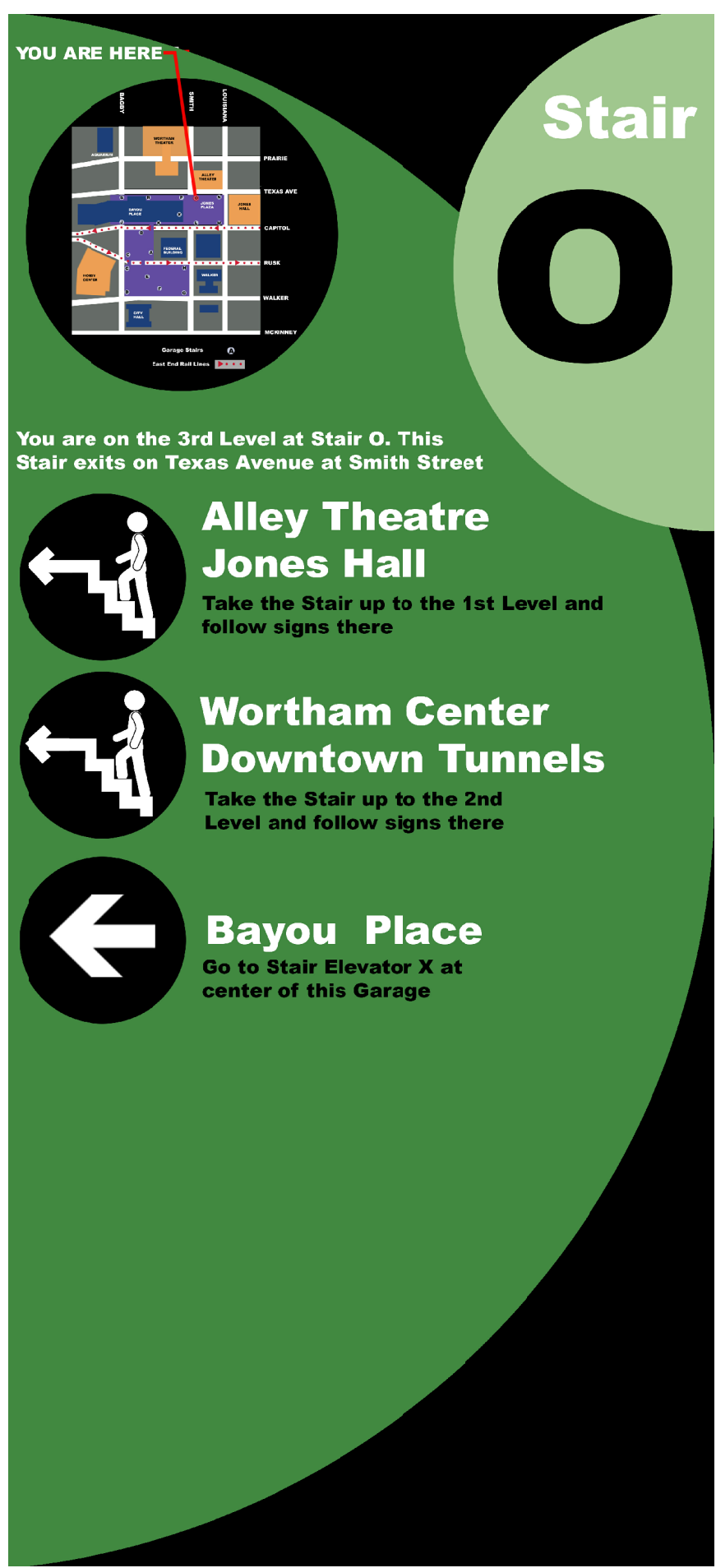

O Stair O Level 1 (O-1)

O Stair O Level 2 (O-2)

O Stair O Level 3 (O-3)

P Stair P Level 1 (P-1)

P Stair P Level 2 (P-2)

P Stair P Level 3 (P-3)

"FIELD CONFIRM VINYL DIMENSIONS PRIOR TO FABRICATION"

J:\25-1883-00-THEATER_DISTRICT_WAYFINDING\05-ARCH\PK-210.DWG 3/23/2016 4:34:50 PM SIMON, ANDRE



HOUSTON THEATER DISTRICT
YELLOW GARAGE SIGNAGE

HOUSTON TEXAS



PROJECT NO:	25-1883.01	
DRAWN BY:	RG	
CHECKED BY:	BBB	
SHEET TITLE:	SIGNAGE DETAILS	
NO.	DATE	DESCRIPTION
5-20-2016		Addendum #1
3-24-2016		Construction Documents
ISSUED:		

PROJECT NO: 25-1883.01
DRAWN BY: RG
CHECKED BY: BBB
SHEET TITLE: SIGNAGE DETAILS

PK-210



R Stair R Level 1 (R-1)



R Stair R Level 2 (R-2)



R Stair R Level 3 (R-3)

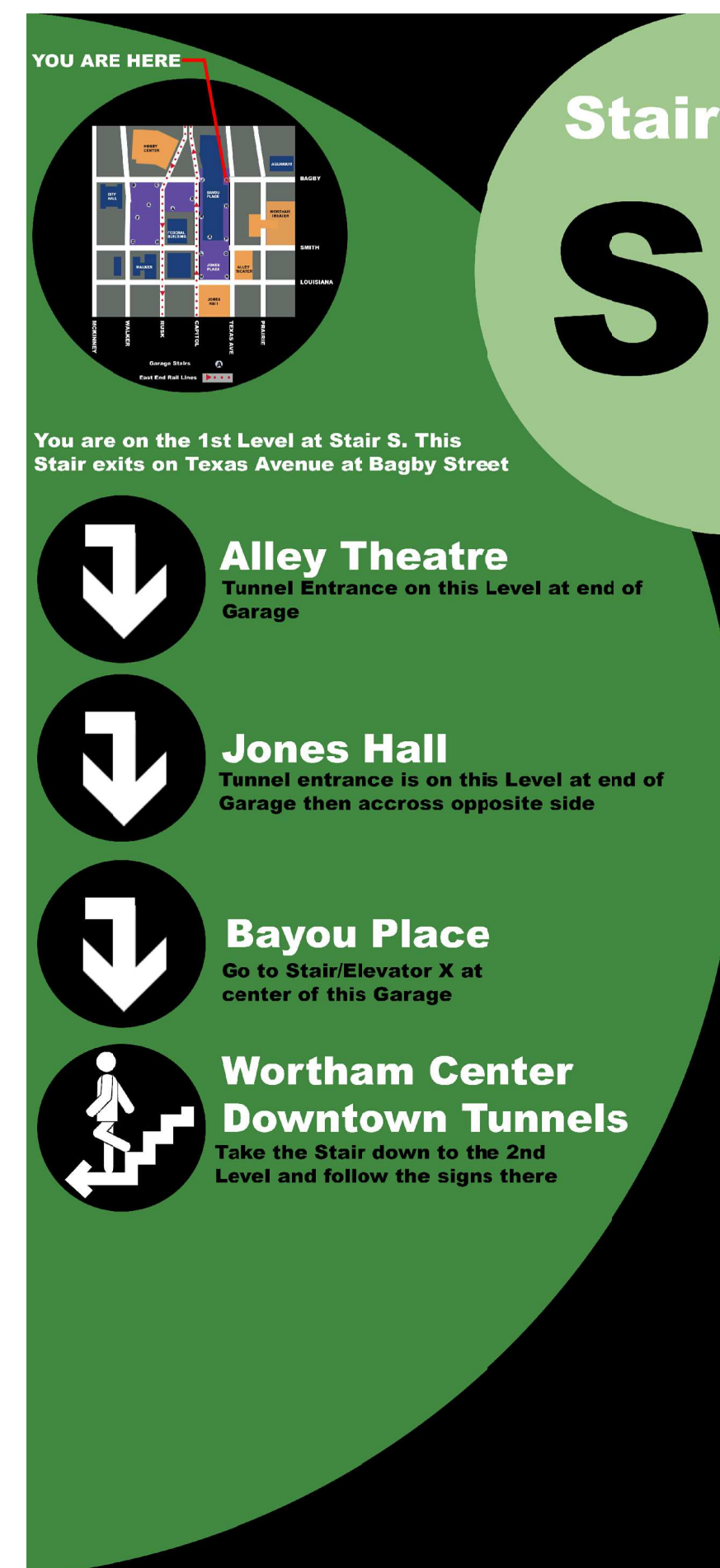

S Stair S Level 1 (S-1)



S Stair S Level 2 (S-2)



S Stair S Level 3 (S-3)

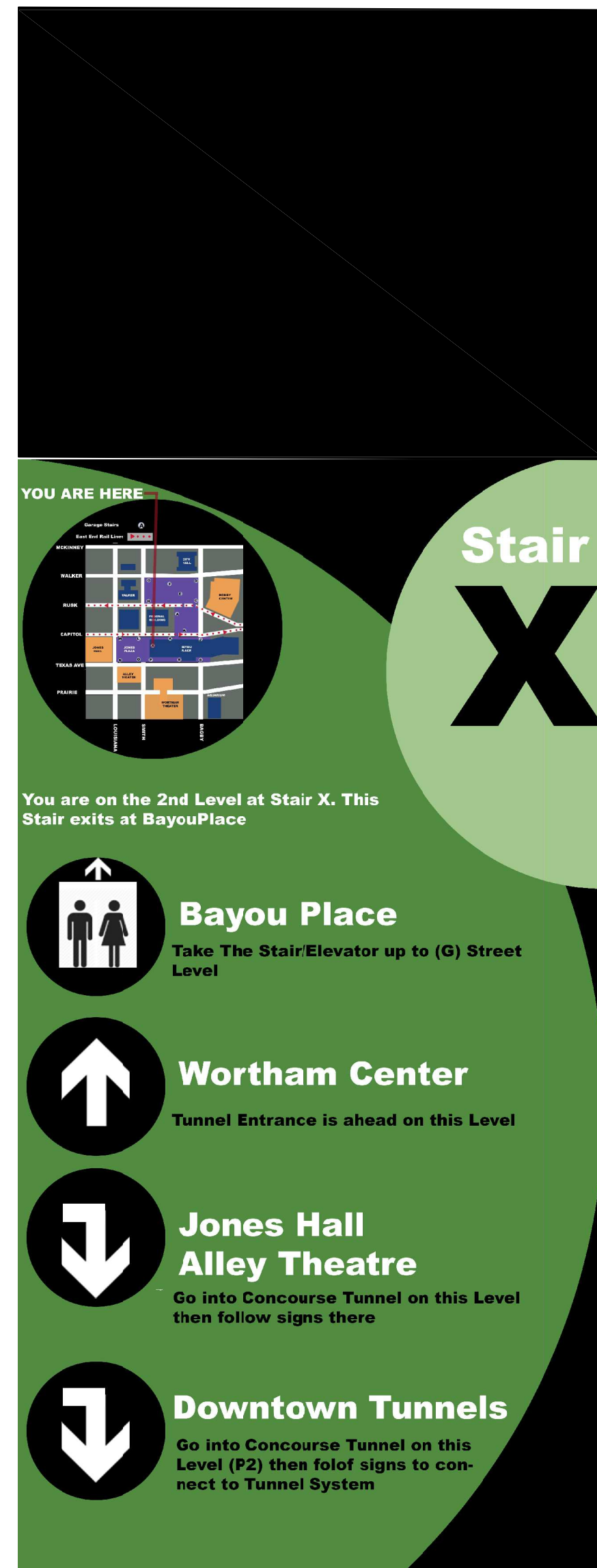
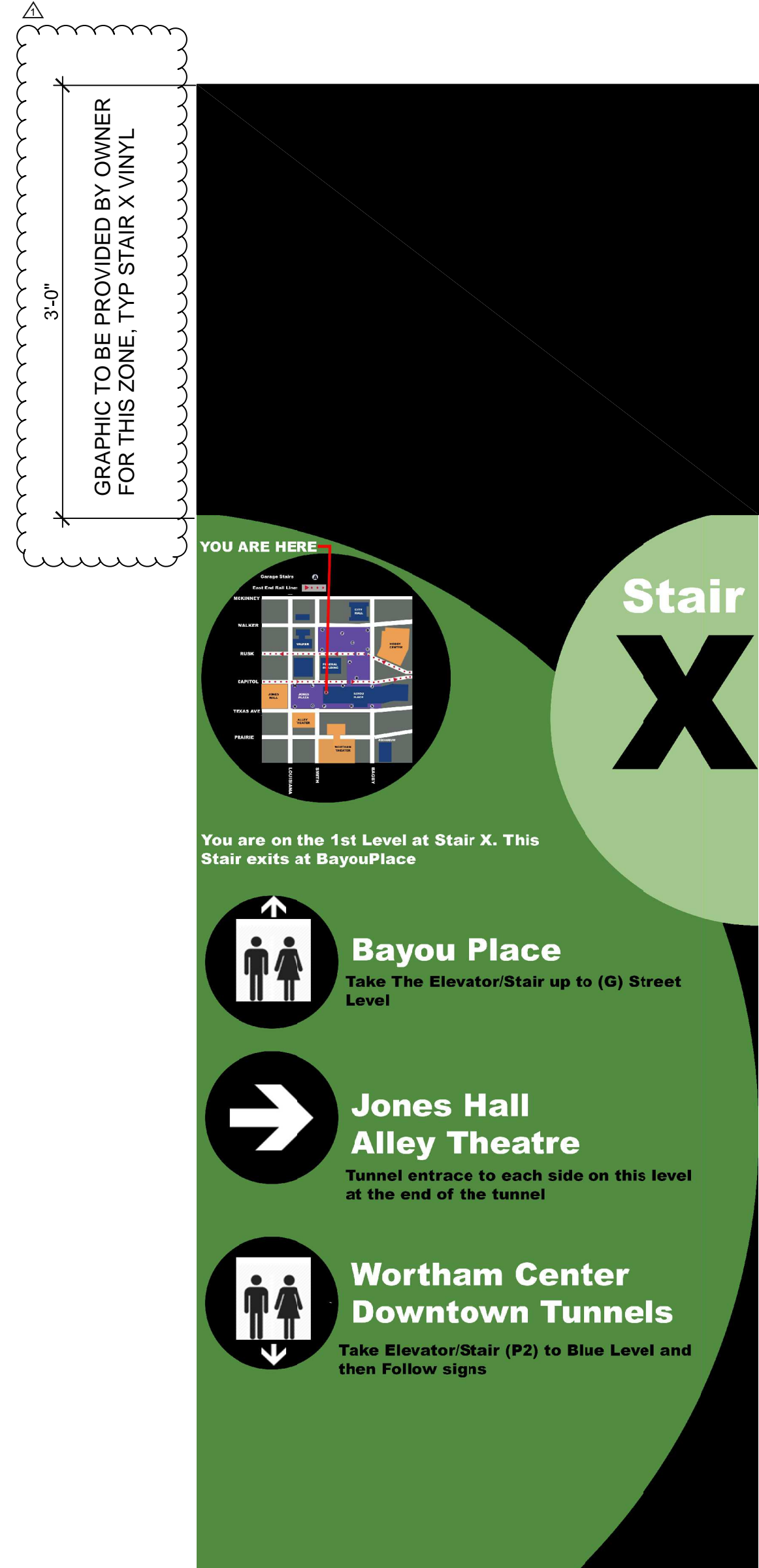

3'-0"
GRAPHIC TO BE PROVIDED BY OWNER FOR THIS ZONE. TYP STAIR X VINYL

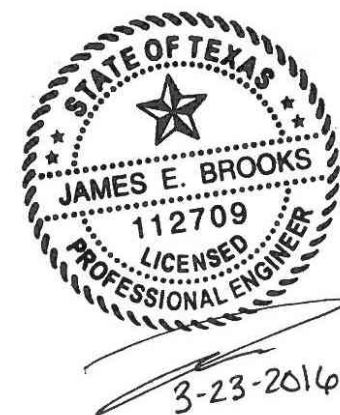

HOUSTON THEATER DISTRICT
YELLOW GARAGE SIGNAGE
HOUSTON TEXAS



NO.	DATE	DESCRIPTION
5-20-2016	5-20-2016	Addendum #1
3-24-2016	3-24-2016	Construction Documents

PROJECT NO: 25-1883.01
DRAWN BY: RG
CHECKED BY: BBB
SHEET TITLE:

SIGNAGE
DETAILS

PK-211