

ISSUED FOR BIDDING - NOT FOR CONSTRUCTION



THESE DRAWINGS ARE PRELIMINARY AND RELEASED UNDER THE SUPERVISION OF ALFREDO E BUSTAMANTE, PE 94588



2525 Bay Area Blvd  
 Suite 400  
 Houston, TX 77058  
 281.280.0068 Ph  
 281.280.0373 Fax  
 www.walkerrestoration.com

Job: Civic Garage Structure, Level 1

Job No: 25-1863.00

Date: 07-31-2015

No.

R-101A

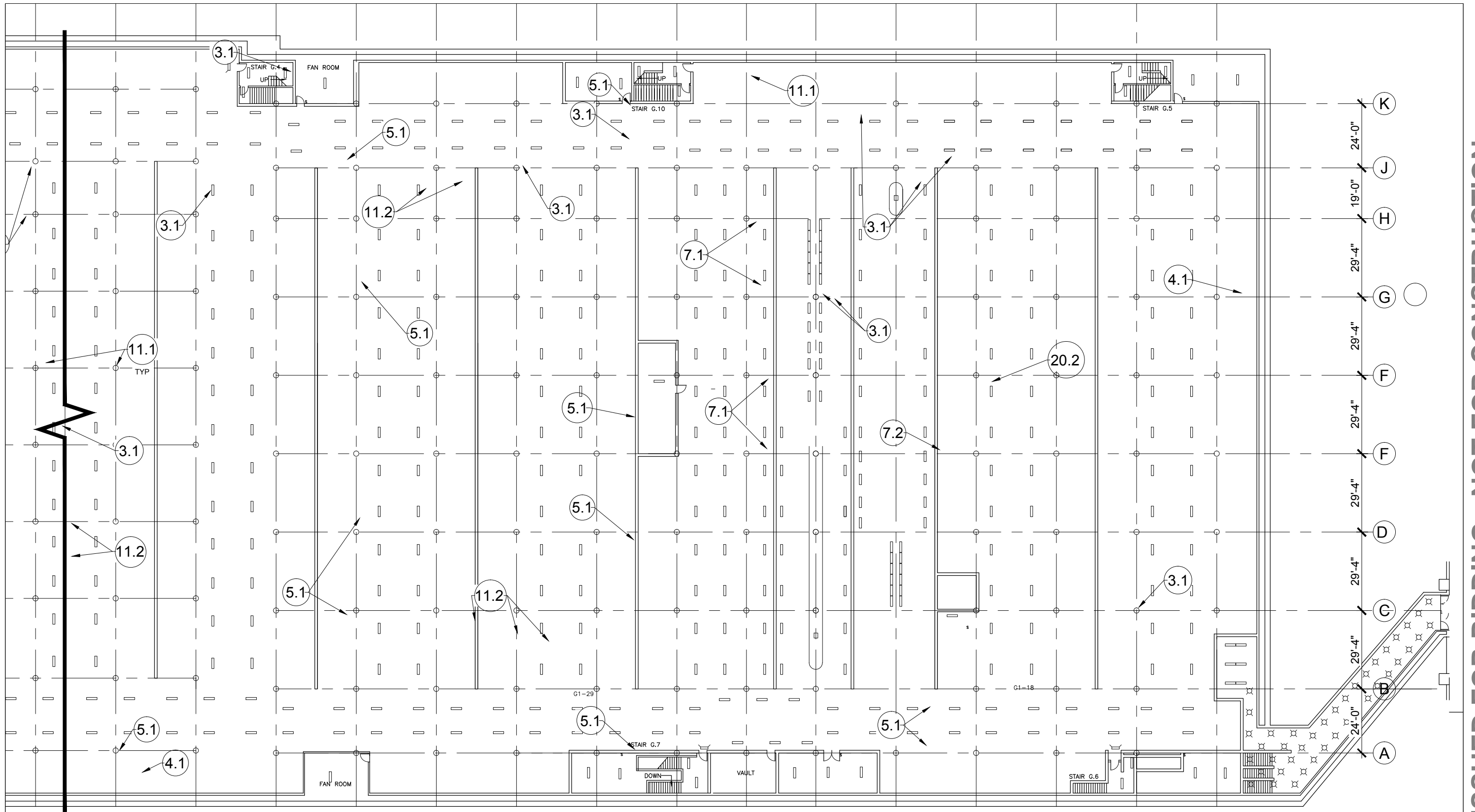

ISSUED FOR BIDDING - NOT FOR CONSTRUCTION



THESE DRAWINGS ARE PRELIMINARY AND RELEASED UNDER THE SUPERVISION OF ALFREDO E BUSTAMANTE, PE 94588



2525 Bay Area Blvd  
Suite 400  
Houston, TX 77058  
281.280.0068 Ph  
281.280.0373 Fax  
www.walkerrestoration.com

Job: Civic Garage Structure, Level 1

Job No: 25-1863.00

Date: 07-31-2015

No.

R-101B

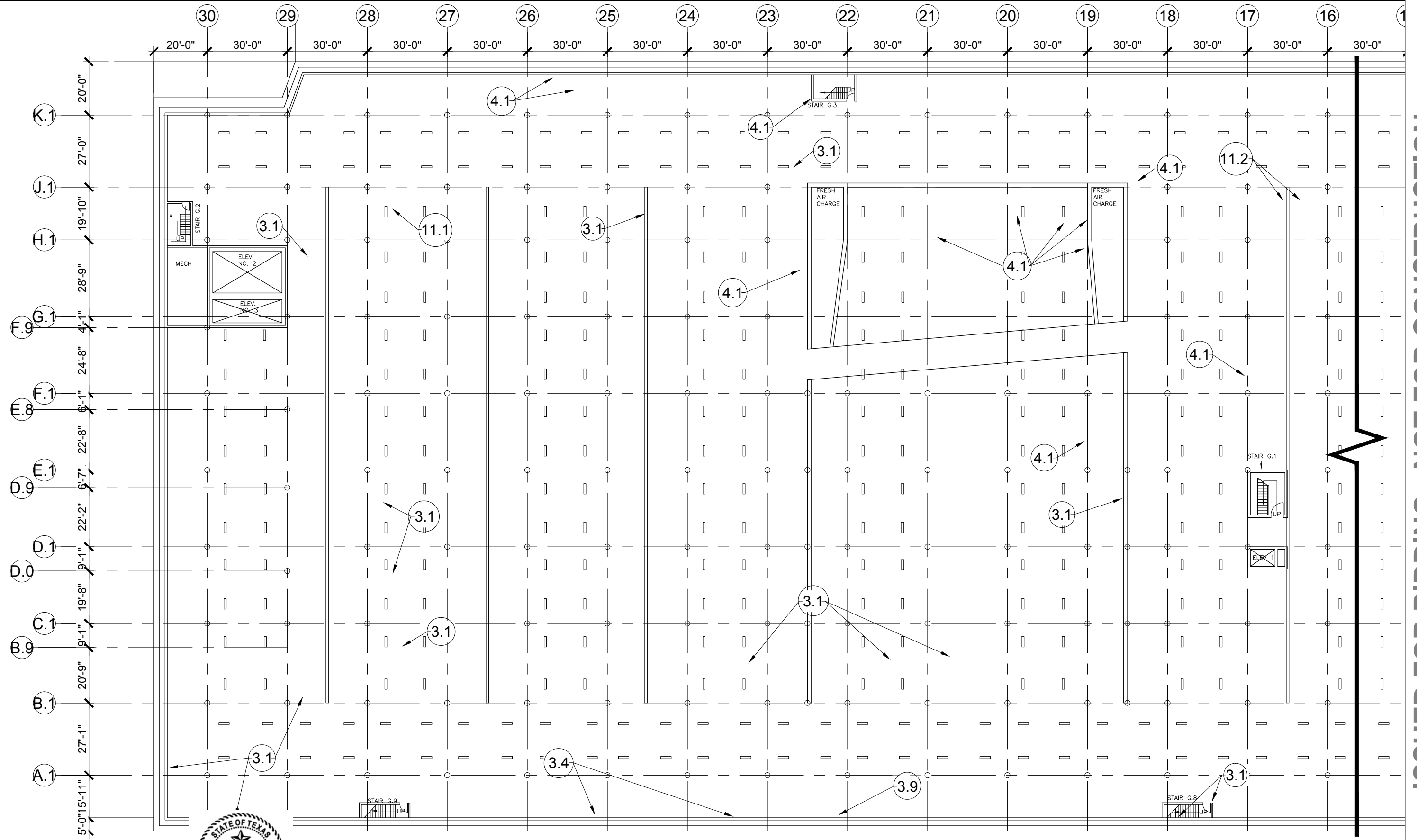

THESE DRAWINGS ARE PRELIMINARY AND RELEASED UNDER THE SUPERVISION OF ALFREDO E BUSTAMANTE, PE 94588



2525 Bay Area Blvd  
Suite 400  
Houston, TX 77058  
281.280.0068 Ph  
281.280.0373 Fax  
www.walkerrestoration.com

Job:	Civic Gragae Structure, Level 2
Job No:	25-1863.00
Date:	07-31-2015

No.  
**R-102A**

ISSUED FOR BIDDING - NOT FOR CONSTRUCTION

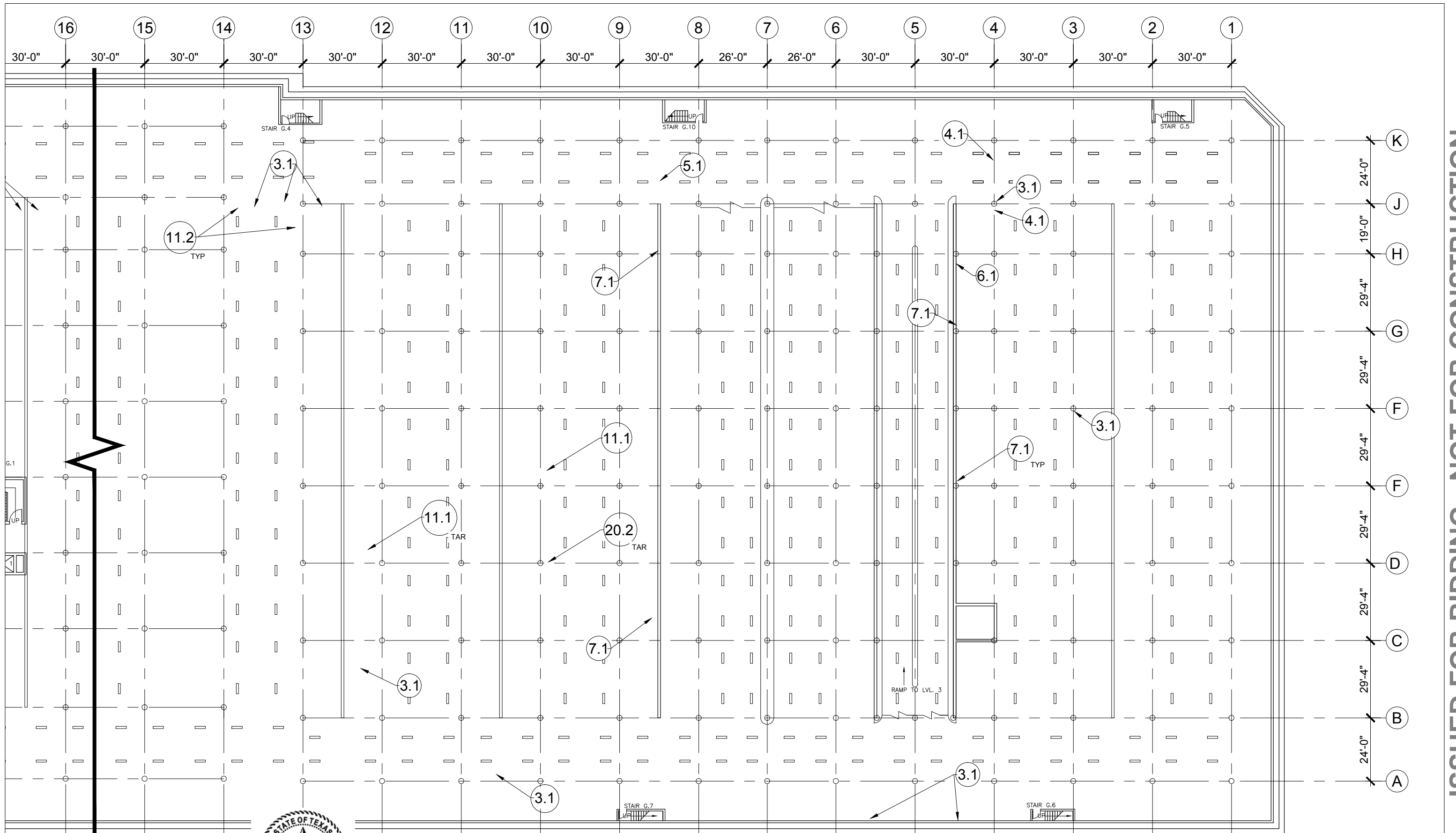

THESE DRAWINGS ARE PRELIMINARY AND RELEASED UNDER THE SUPERVISION OF ALFREDO E BUSTAMANTE, PE 94588



2525 Bay Area Blvd  
Suite 400  
Houston, TX 77058  
281.280.0068 Ph  
281.280.0373 Fax  
www.walkerrestoration.com

Job:	Civic Garage Structure, Level 2	No.	
Job No:	25-1863.00		R-102B
Date:	07-31-2015		

ISSUED FOR BIDDING - NOT FOR CONSTRUCTION

ISSUED FOR BIDDING - NOT FOR CONSTRUCTION

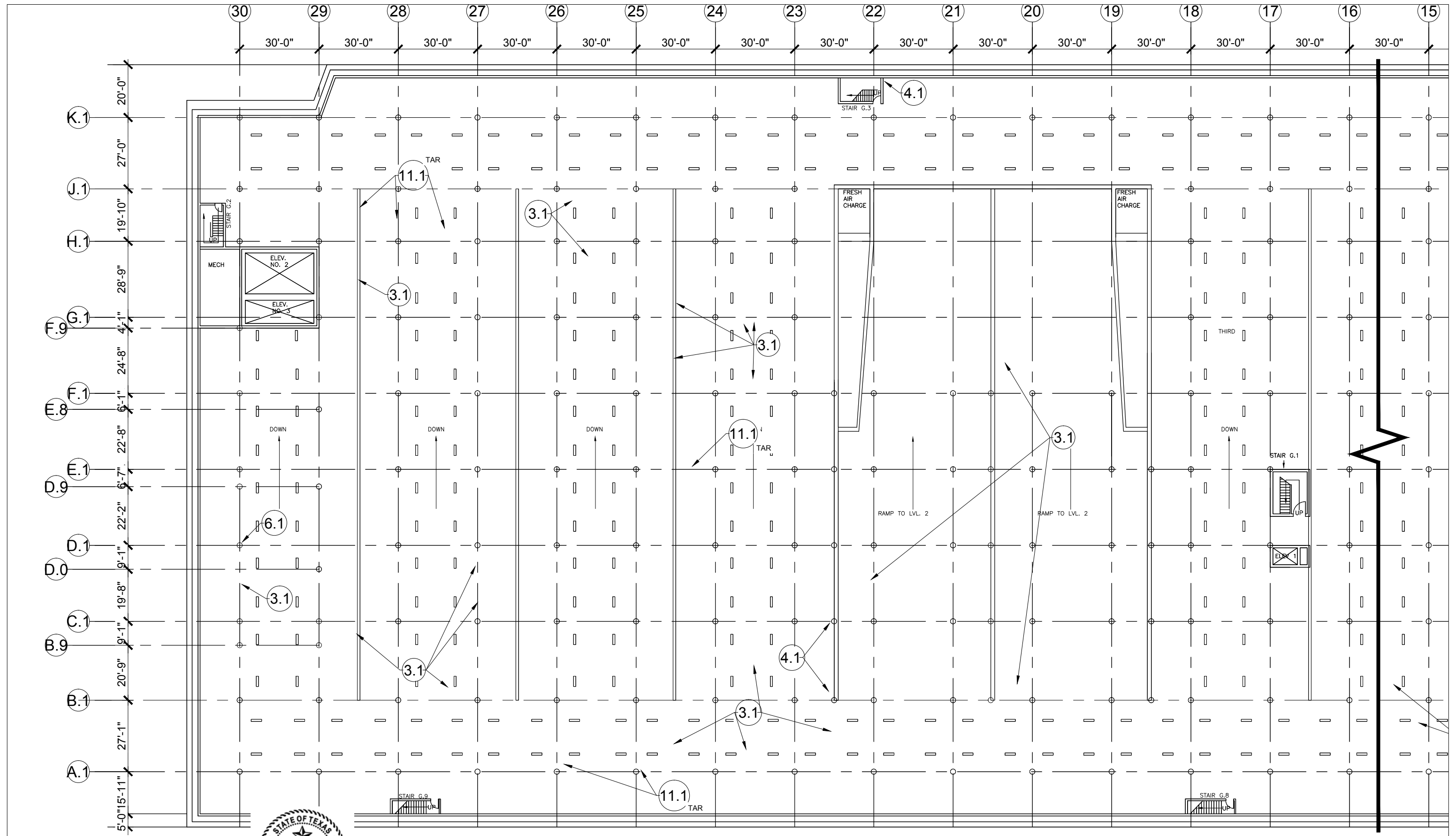

THESE DRAWINGS ARE PRELIMINARY AND RELEASED UNDER THE SUPERVISION OF ALFREDO E BUSTAMANTE, PE 94588



2525 Bay Area Blvd  
Suite 400  
Houston, TX 77058  
281.280.0068 Ph  
281.280.0373 Fax  
www.walkerrestoration.com

Job: Civic Garage Structure, Level 3	No.
Job No: 25-1863.00	R-103A
Date: 07-31-2015	

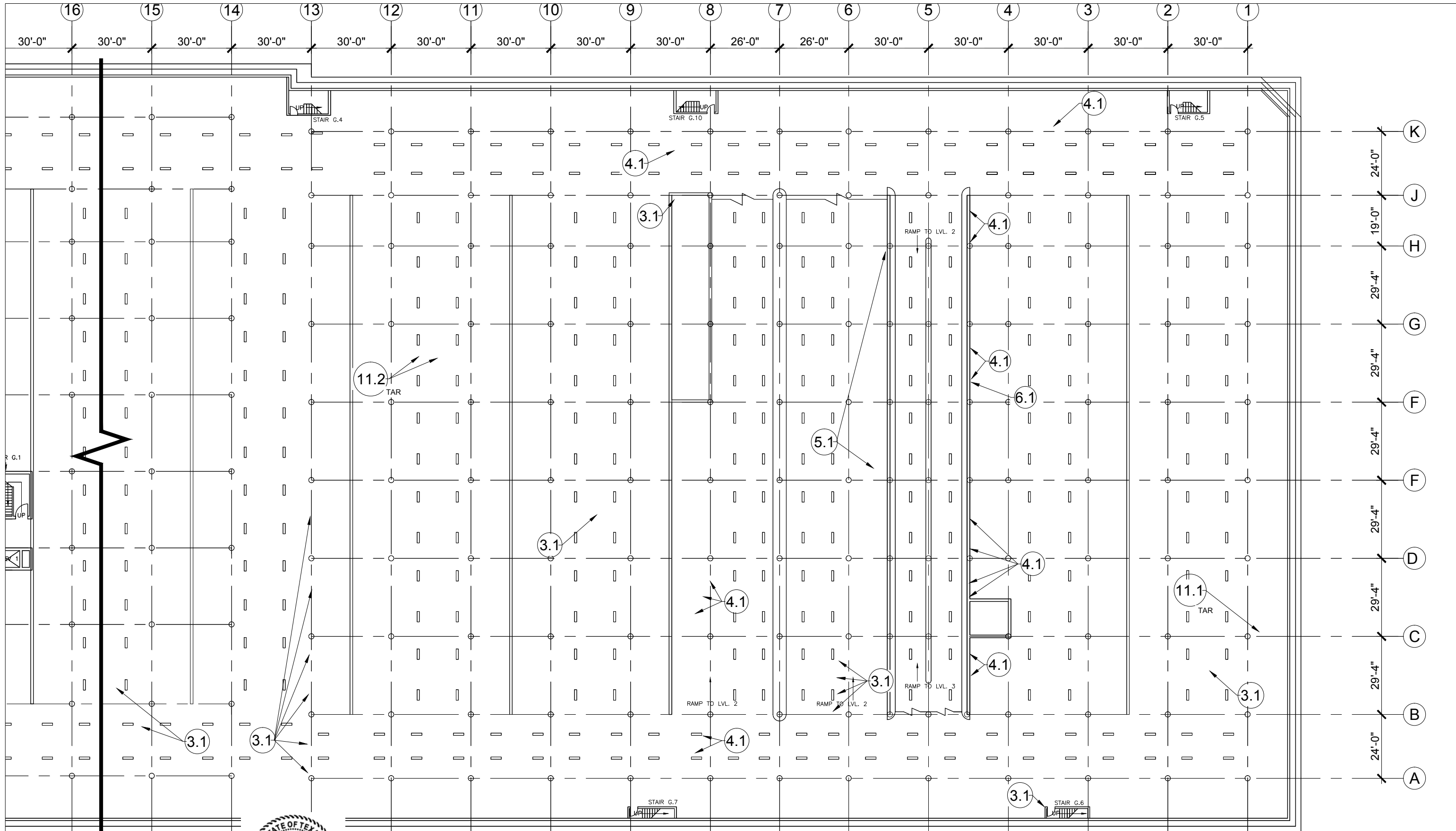

THESE DRAWINGS ARE PRELIMINARY AND RELEASED UNDER THE SUPERVISION OF ALFREDO E BUSTAMANTE, PE 94588



2525 Bay Area Blvd  
Suite 400  
Houston, TX 77058  
281.280.0068 Ph  
281.280.0373 Fax  
www.walkerrestoration.com

Job: Civic Garage Structure, Level 3  
Job No: 25-1863.00  
Date: 07-31-2015

No. R-103B

ISSUED FOR BIDDING - NOT FOR CONSTRUCTION

ISSUED FOR BIDDING - NOT FOR CONSTRUCTION

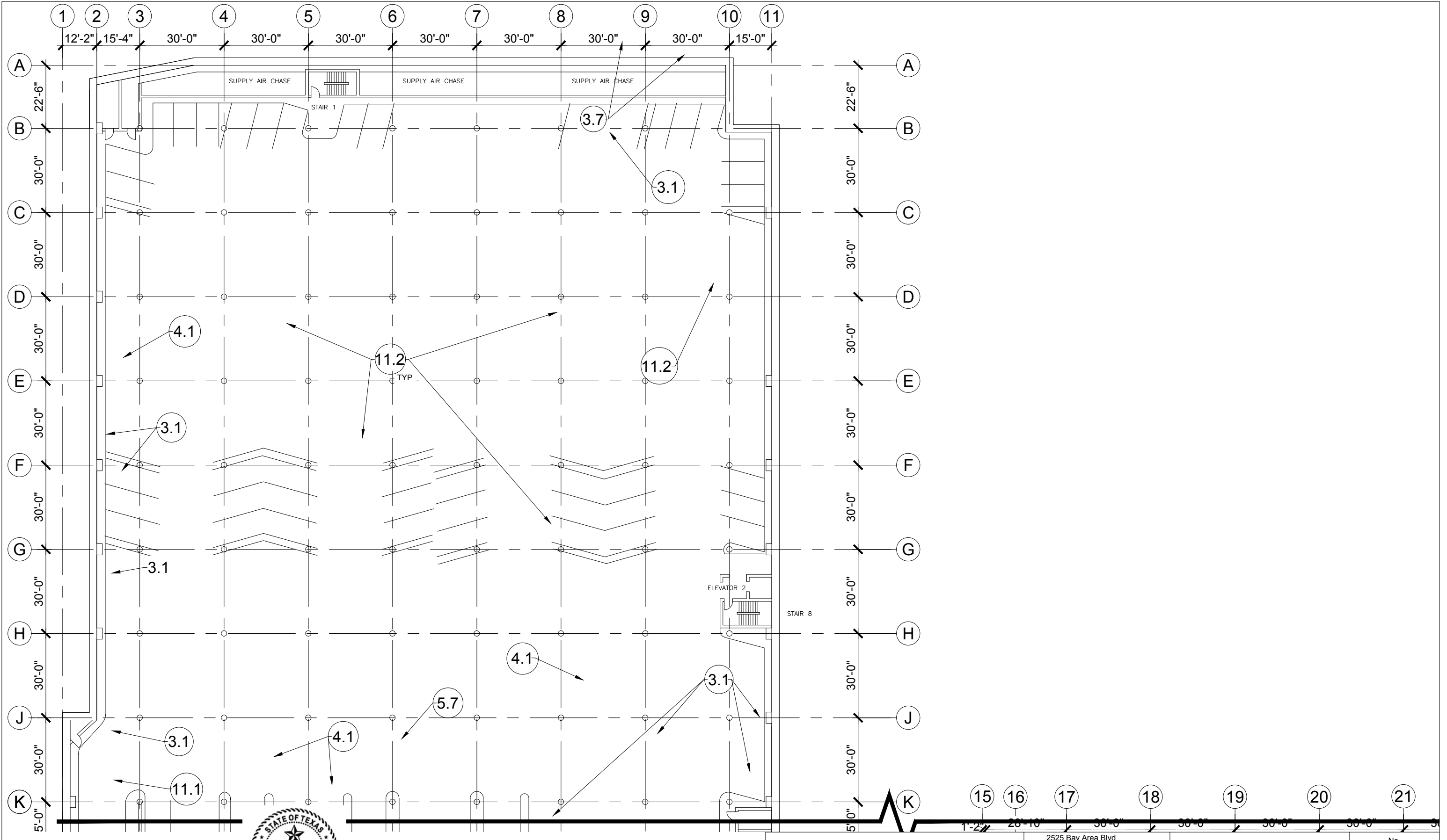

THESE DRAWINGS ARE PRELIMINARY AND RELEASED UNDER THE SUPERVISION OF ALFREDO E BUSTAMANTE, PE 94588



2525 Bay Area Blvd  
 Suite 400  
 Houston, TX 77058  
 281.280.0068 Ph  
 281.280.0373 Fax  
 www.walkerrestoration.com

Job: Tranquility Parking Grage, Level 1  
 Job No: 25-1863.00  
 Date: 07-31-2015

No. R-104A

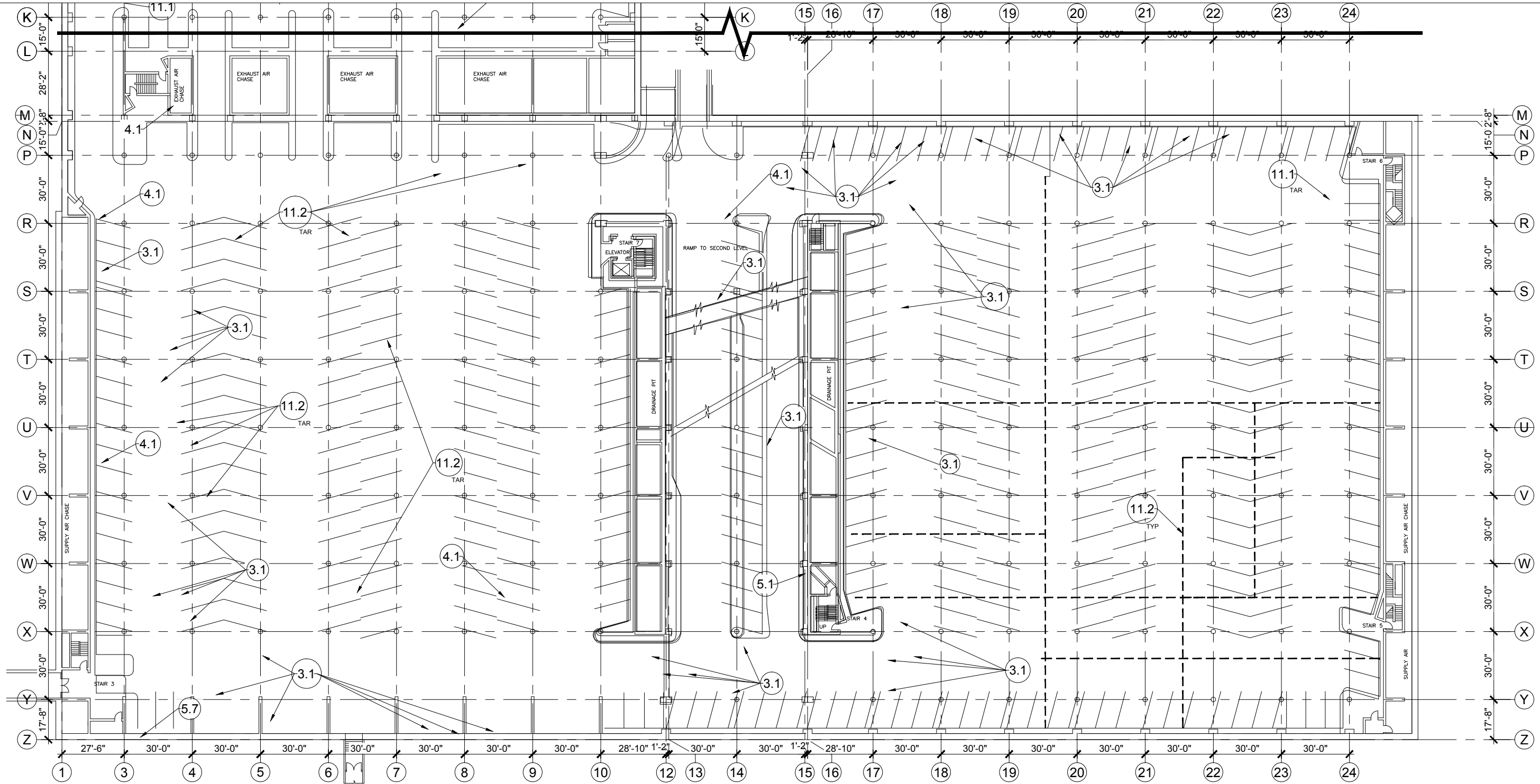

THESE DRAWINGS ARE PRELIMINARY AND RELEASED UNDER THE SUPERVISION OF ALFREDO E BUSTAMANTE, PE 94588



2525 Bay Area Blvd  
Suite 400  
Houston, TX 77058  
281.280.0068 Ph  
281.280.0373 Fax  
www.walkerrestoration.com

Job: Tranquility Parking Structure, Level 1

Job No: 25-1863.00

Date: 07-31-2015

No.

R-104A



ISSUED FOR BIDDING - NOT FOR CONSTRUCTION

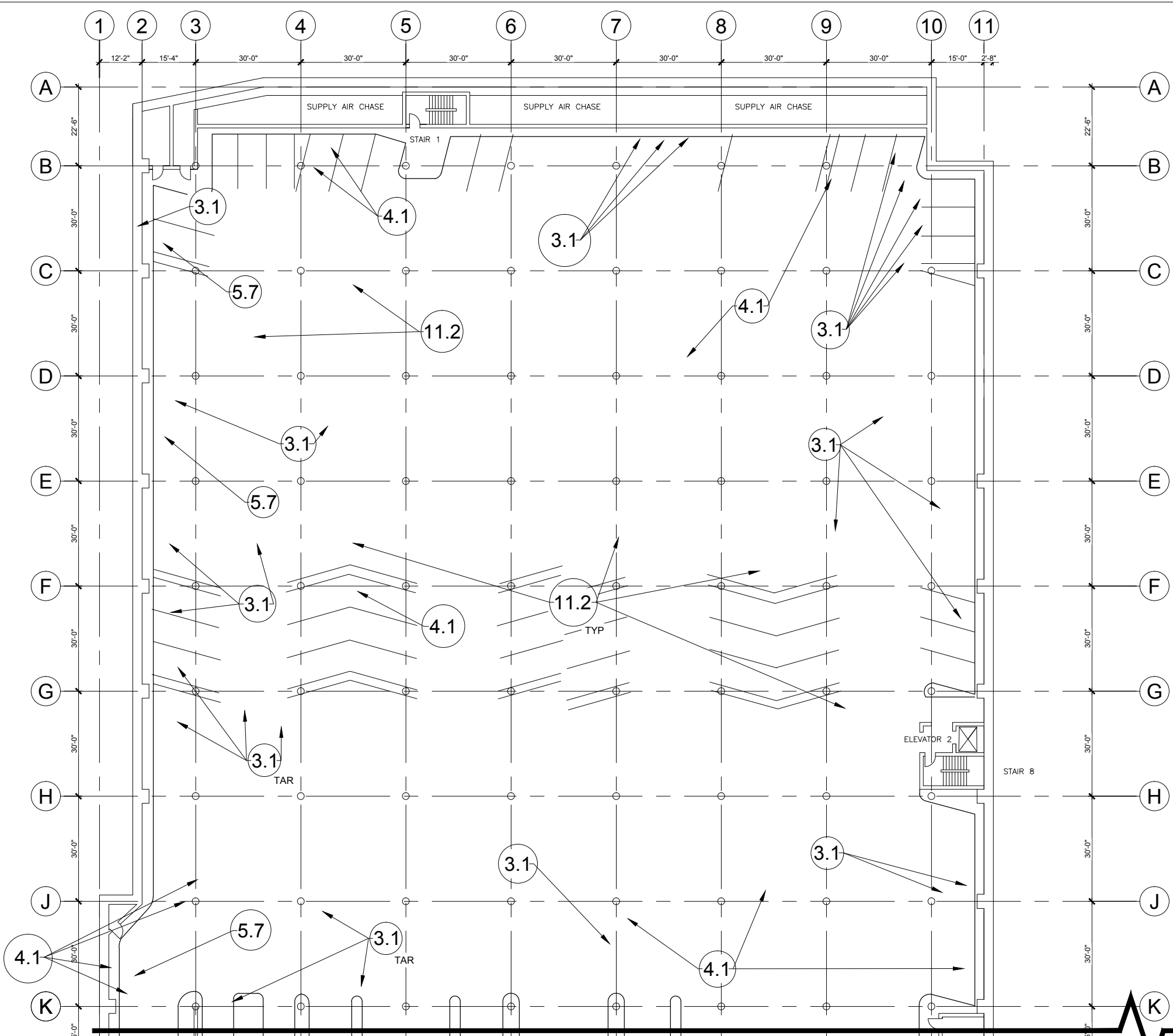

THESE DRAWINGS ARE PRELIMINARY AND RELEASED UNDER THE SUPERVISION OF ALFREDO E BUSTAMANTE, PE 94588



2525 Bay Area Blvd  
 Suite 400  
 Houston, TX 77058  
 281.280.0068 Ph  
 281.280.0373 Fax  
 www.walkerrestoration.com

Job:	XX
Job No:	25-1863.00
Date:	07-31-2015

No.  
**R-105A**



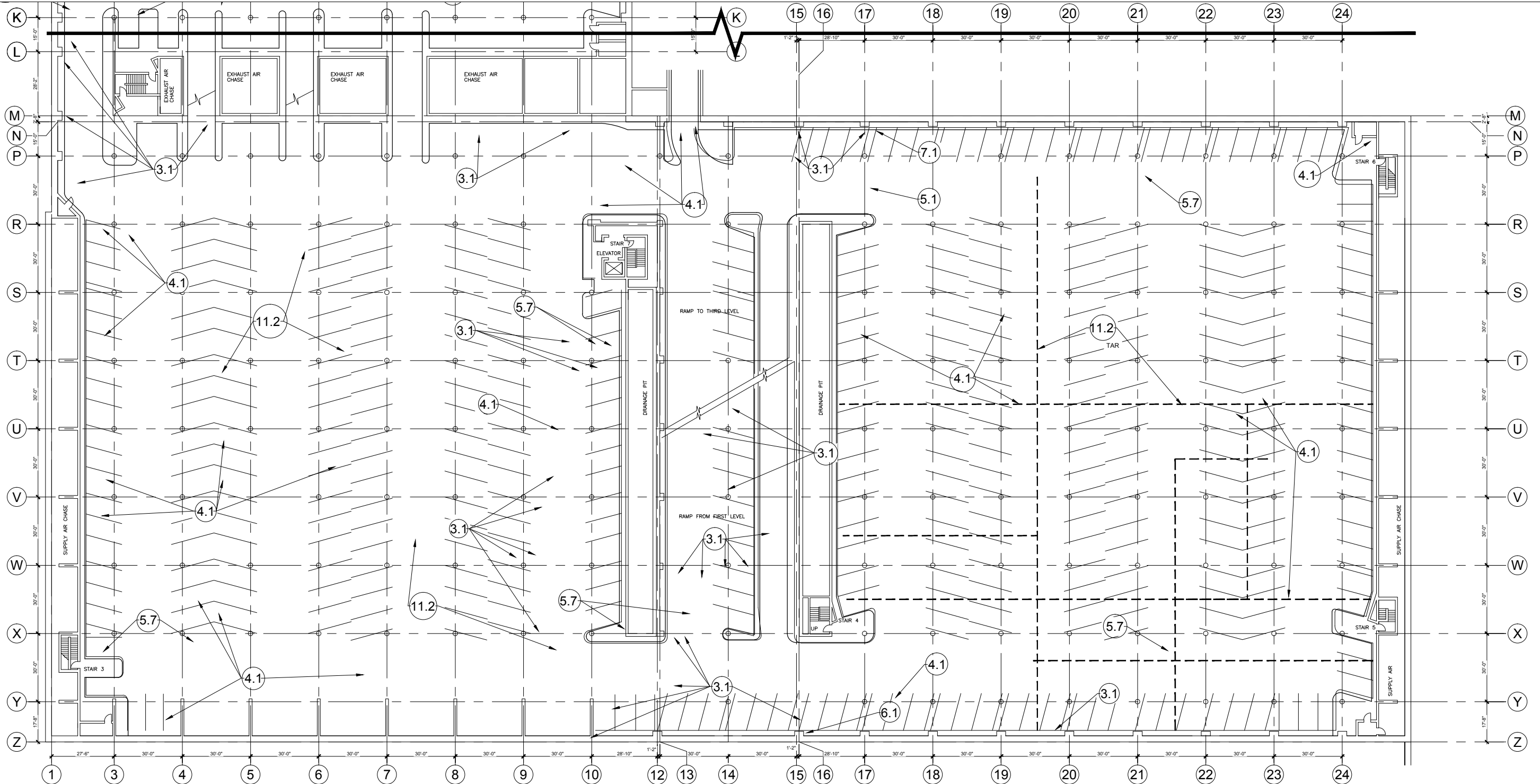

THESE DRAWINGS ARE PRELIMINARY AND RELEASED UNDER THE SUPERVISION OF ALFREDO E BUSTAMANTE, PE 94588



2525 Bay Area Blvd  
 Suite 400  
 Houston, TX 77058  
 281.280.0068 Ph  
 281.280.0373 Fax  
 www.walkerrestoration.com

Job: Tranquility parking structure, Level 2  
 Job No: 25-1863.00  
 Date: 07-31-2015

No.  
**R-105B**

ISSUED FOR BIDDING - NOT FOR CONSTRUCTION

ISSUED FOR BIDDING - NOT FOR CONSTRUCTION

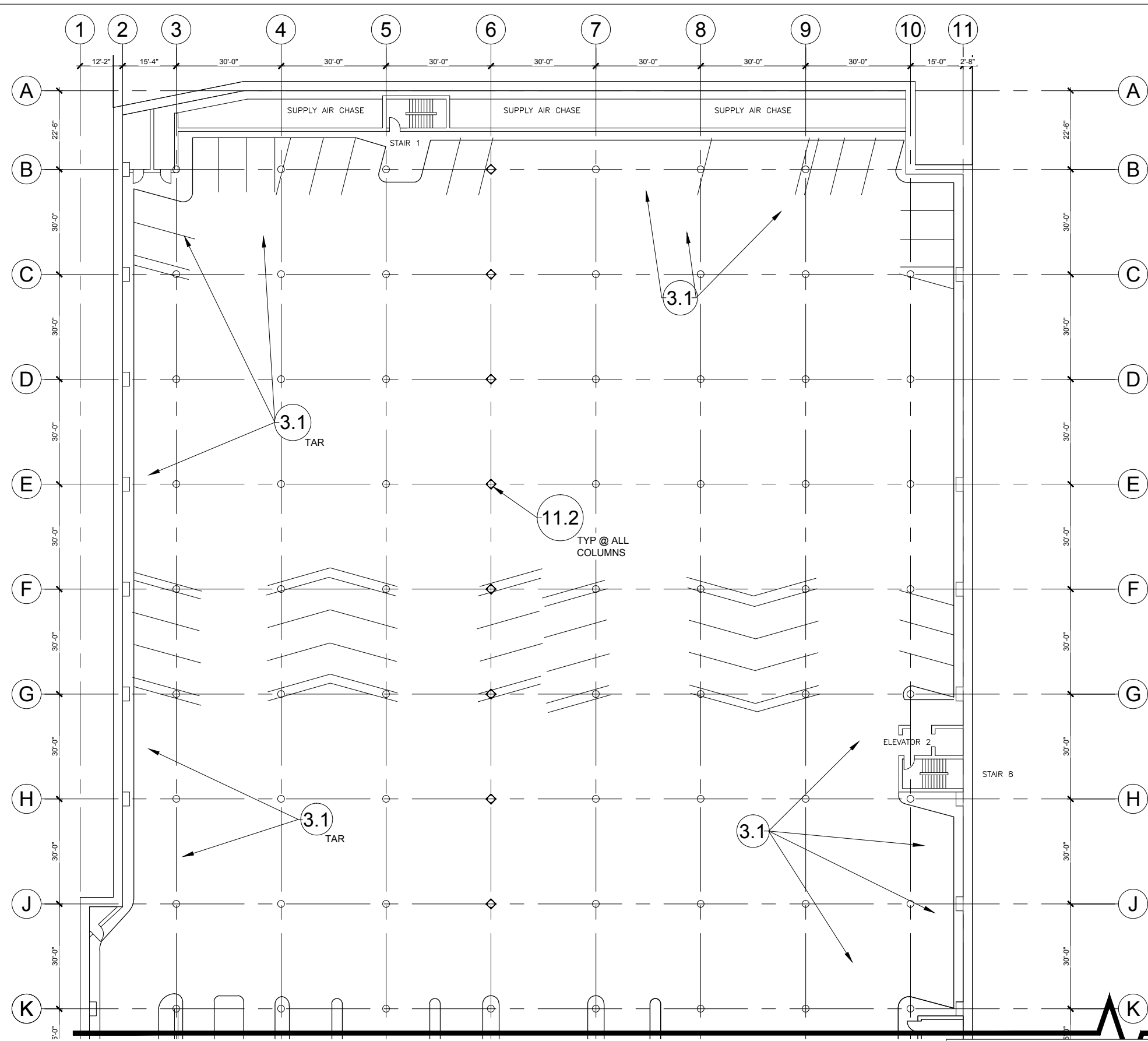

THESE DRAWINGS ARE PRELIMINARY AND RELEASED UNDER THE SUPERVISION OF ALFREDO E BUSTAMANTE, PE 94588

15 16 17 18 19 20 21



2525 Bay Area Blvd  
Suite 400  
Houston, TX 77058  
281.280.0068 Ph  
281.280.0373 Fax  
www.walkerrestoration.com

Job: Tranquility Parking Structure, Level 3  
Job No: 25-1863.00  
Date: 07-31-2015

No. R-106A

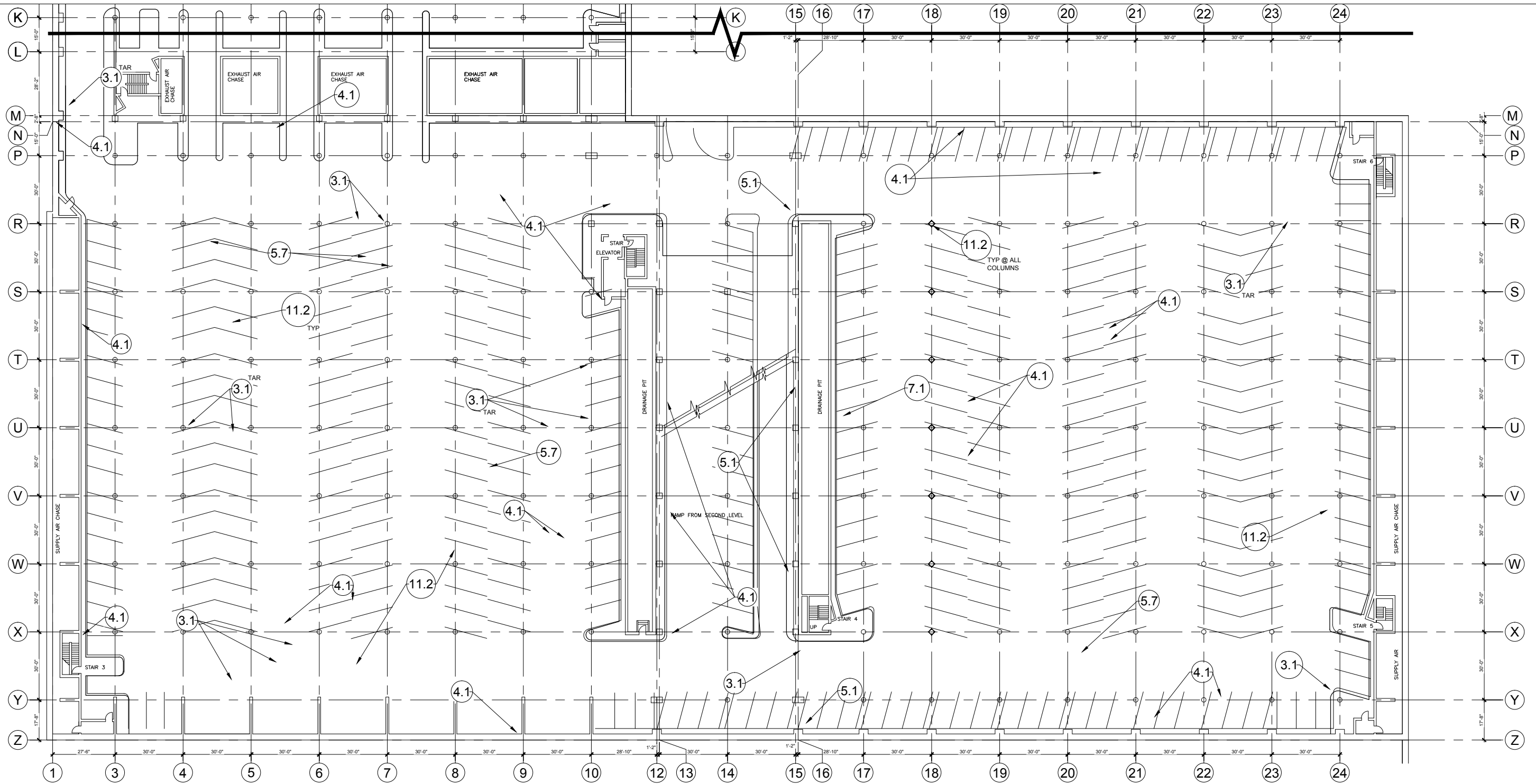

THESE DRAWINGS ARE PRELIMINARY AND RELEASED UNDER THE SUPERVISION OF ALFREDO E BUSTAMANTE, PE 94588



2525 Bay Area Blvd  
Suite 400  
Houston, TX 77058  
281.280.0068 Ph  
281.280.0373 Fax  
www.walkerrestoration.com

Job: Tranquility Parking Structure, Level 3  
Job No: 25-1863.00  
Date: 07-31-2015

No.  
**R-106B**

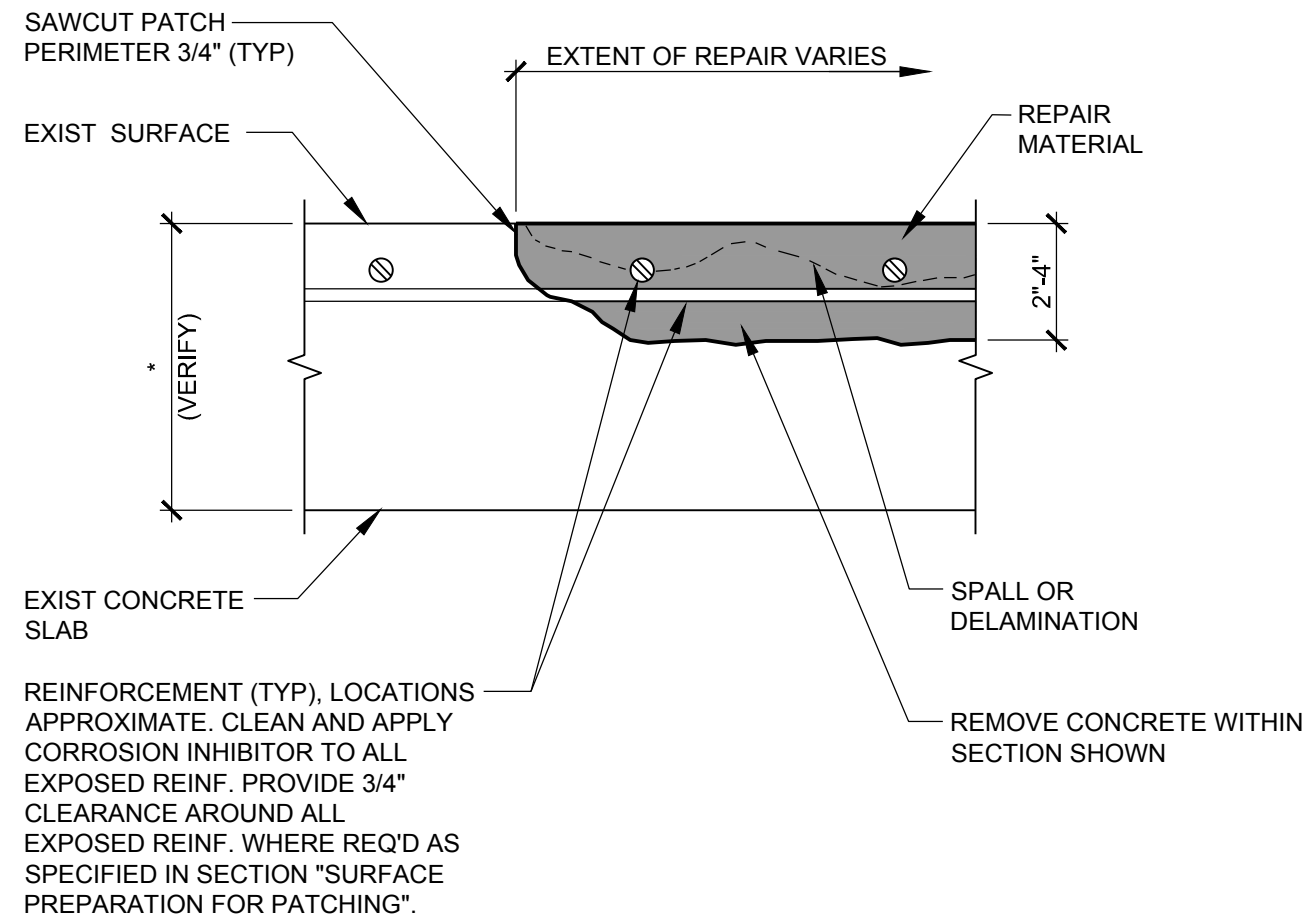

3.1 **FLOOR REPAIR - PARTIAL DEPTH**

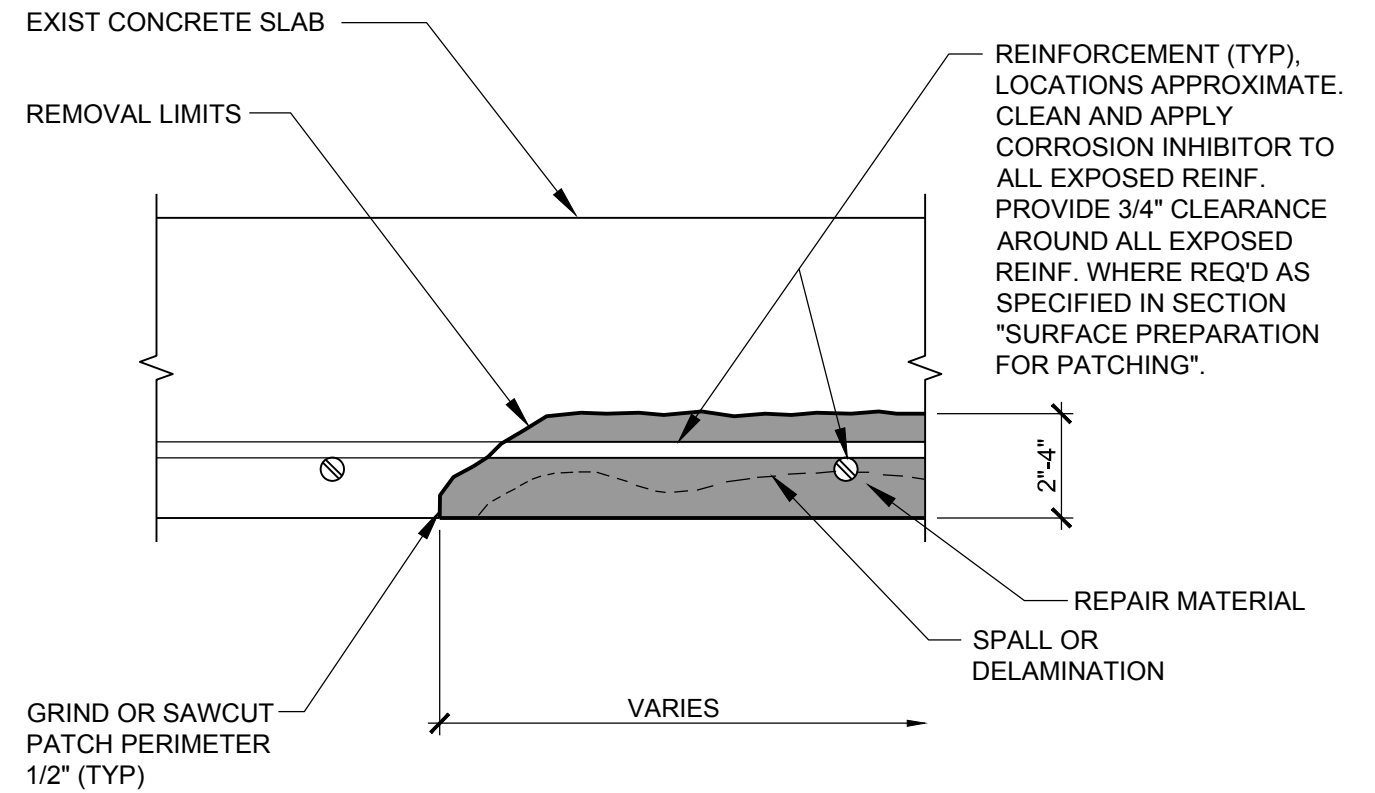

4.1 **CEILING REPAIR-PARTIAL DEPTH**



THESE DRAWINGS ARE PRELIMINARY AND RELEASED UNDER THE SUPERVISION OF ALFREDO E BUSTAMANTE, PE 94588



2525 Bay Area Blvd  
Suite 400  
Houston, TX 77058  
281.280.0068 Ph  
281.280.0373 Fax  
www.walkerrestoration.com

Job:	Tranquility Parking Structure, Level 3
Job No:	25-1863.00
Date:	07-31-2015

No.  
**R-500**

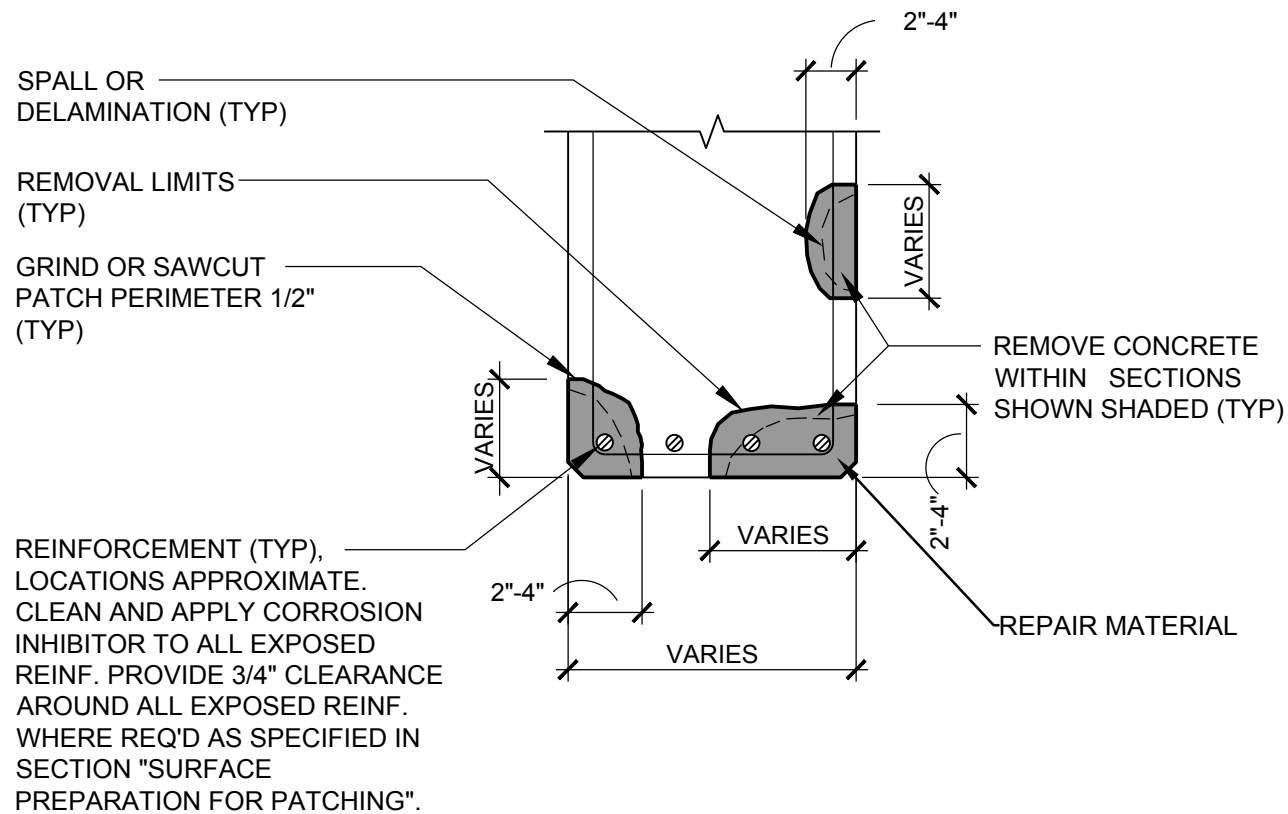

5.1 **BEAM REPAIR-PARTIAL DEPTH**

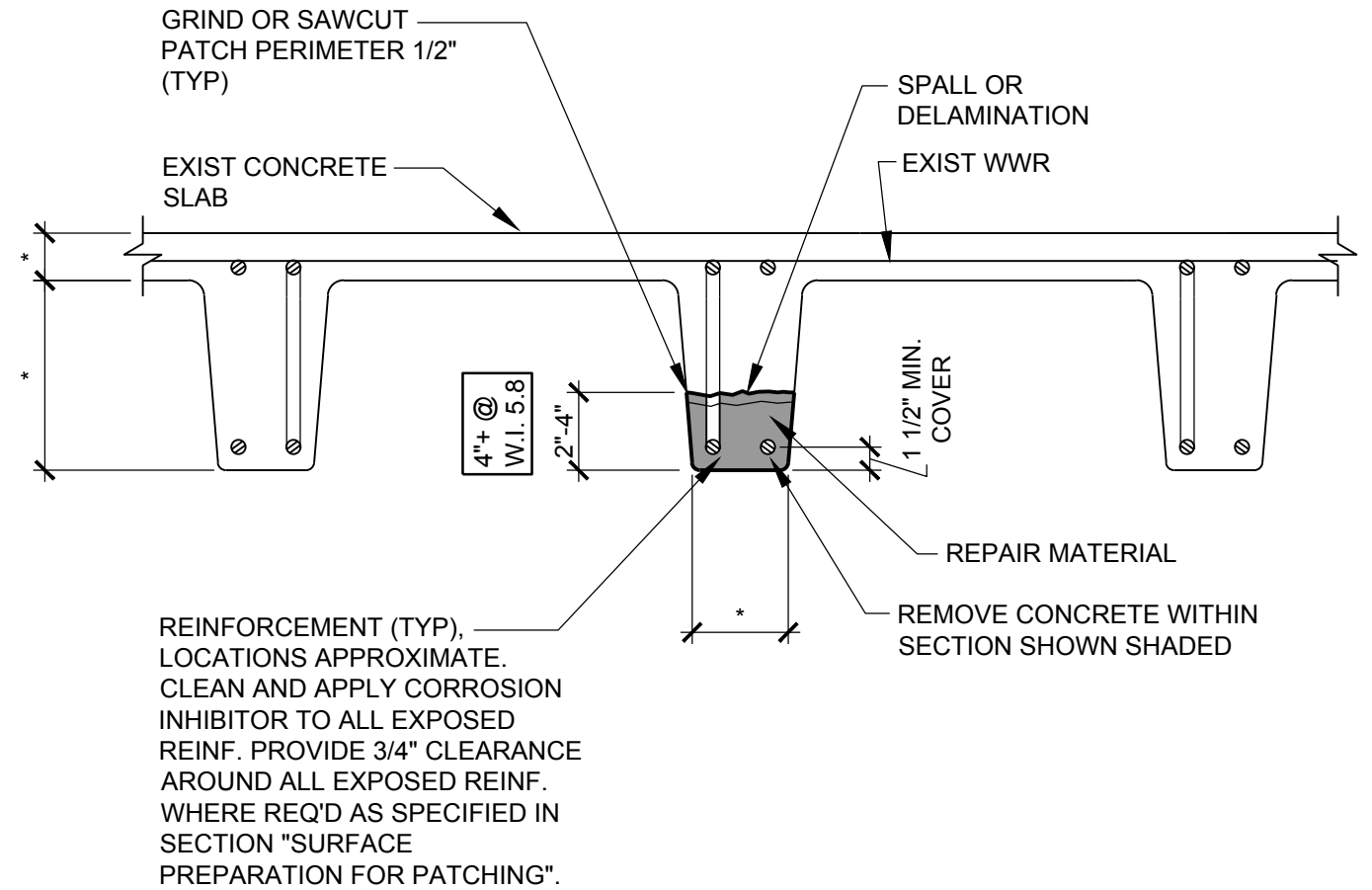

5.7 **JOIST REPAIR-PARTIAL DEPTH**



THESE DRAWINGS ARE PRELIMINARY AND RELEASED UNDER THE SUPERVISION OF ALFREDO E BUSTAMANTE, PE 94588



2525 Bay Area Blvd  
Suite 400  
Houston, TX 77058  
281.280.0068 Ph  
281.280.0373 Fax  
www.walkerrestoration.com

Job:	Tranquility Parking Structure, Level 3
Job No:	25-1863.00
Date:	07-31-2015

No.  
**R-501**

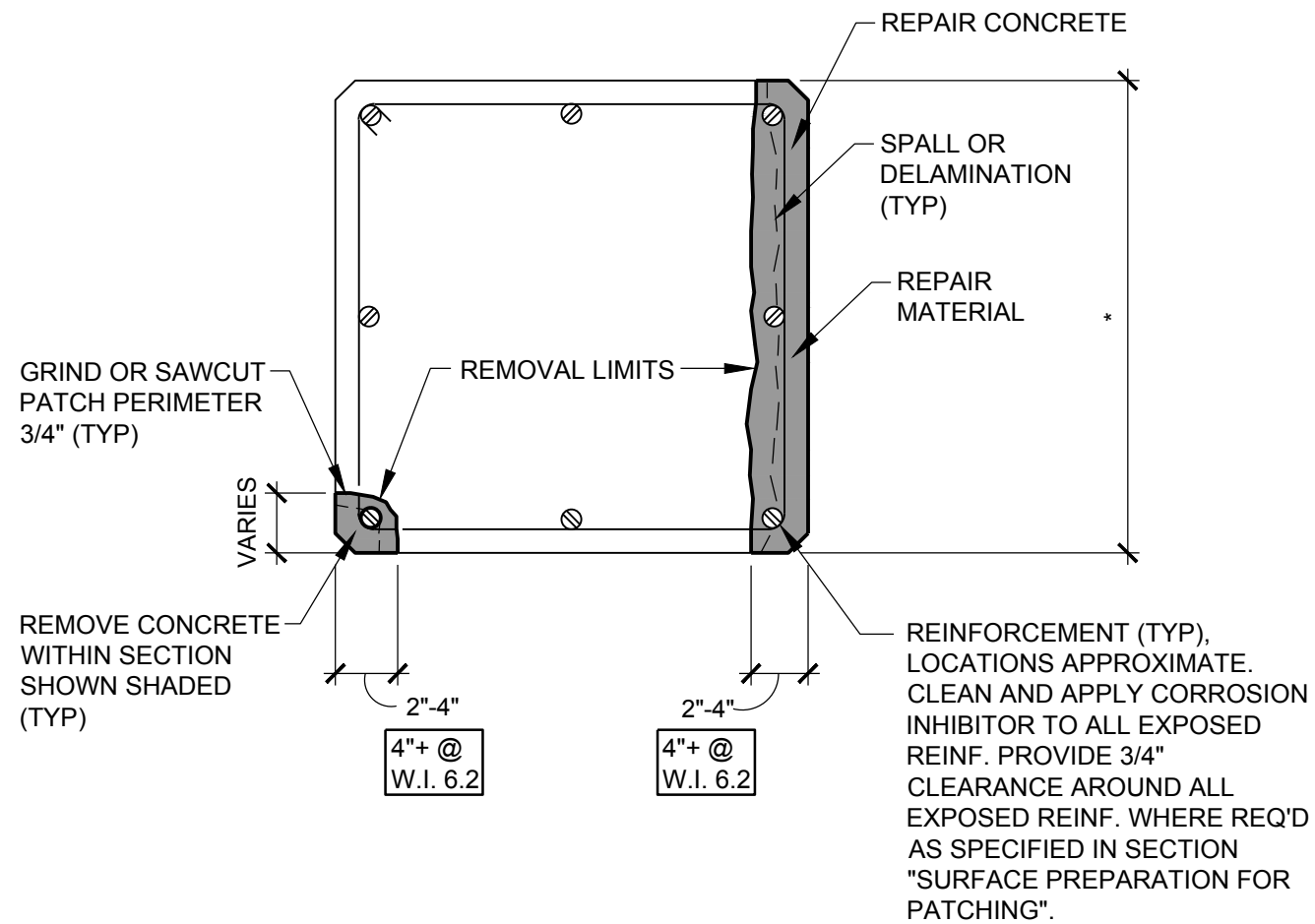

- NOTES:**
1. COLUMN TIES WHICH HAVE LOST MORE THAN 15% OF ORIGINAL CROSS SECTIONAL AREA SHALL BE SUPPLEMENTED AS ENGINEER DIRECTS.
  2. NUMBER AND LOCATION OF REINFORCEMENT SHOWN MAY DIFFER FROM ACTUAL FIELD CONDITIONS.

6.1 **COLUMN REPAIR-PARTIAL DEPTH**



THESE DRAWINGS ARE PRELIMINARY AND RELEASED UNDER THE SUPERVISION OF ALFREDO E BUSTAMANTE, PE 94588

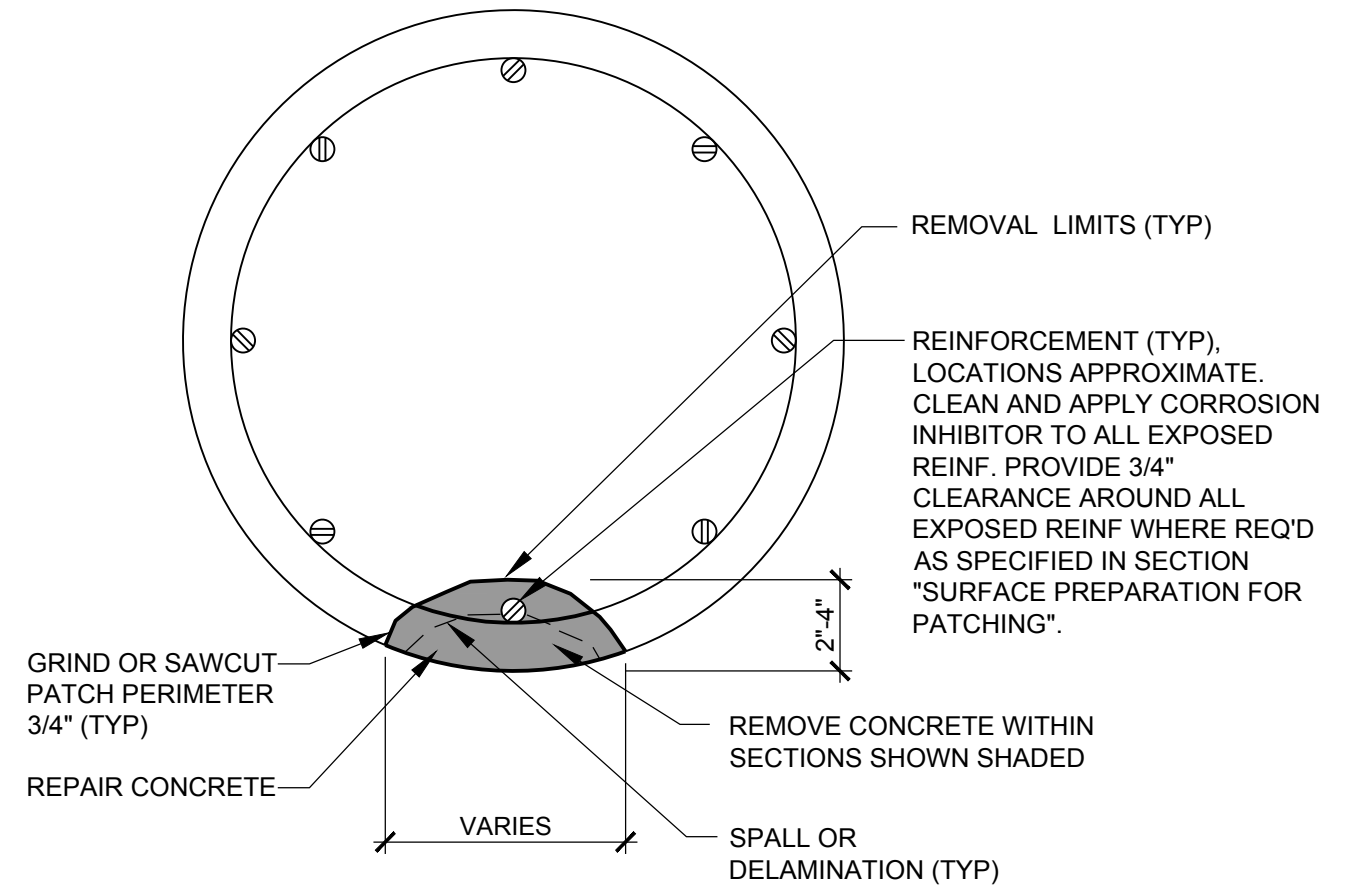

- NOTES:**
1. COLUMN TIES WHICH HAVE LOST MORE THAN 15% OF ORIGINAL CROSS SECTIONAL AREA SHALL BE SUPPLEMENTED AS ENGINEER DIRECTS.
  2. NUMBER AND LOCATION OF REINFORCEMENT SHOWN MAY DIFFER FROM ACTUAL FIELD CONDITIONS.

6.1.1 **COLUMN REPAIR-PARTIAL DEPTH**

	2525 Bay Area Blvd Suite 400 Houston, TX 77058 281.280.0068 Ph 281.280.0373 Fax www.walkerrestoration.com	Job: Tranquility Parking Structure, Level 3	No. <b>R-502</b>
		Job No: 25-1863.00	
		Date: 07-31-2015	

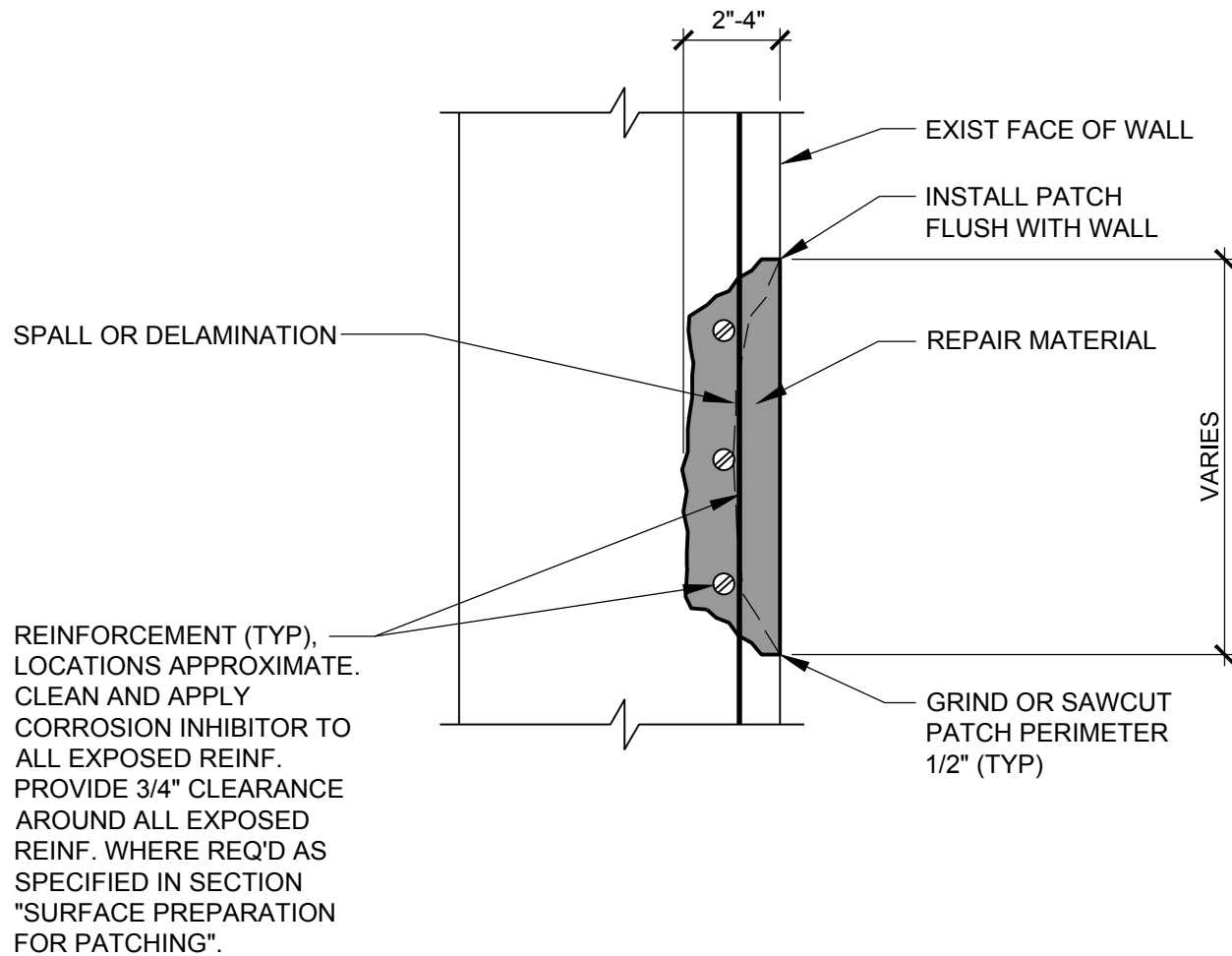

7.1 WALL REPAIR-PARTIAL DEPTH

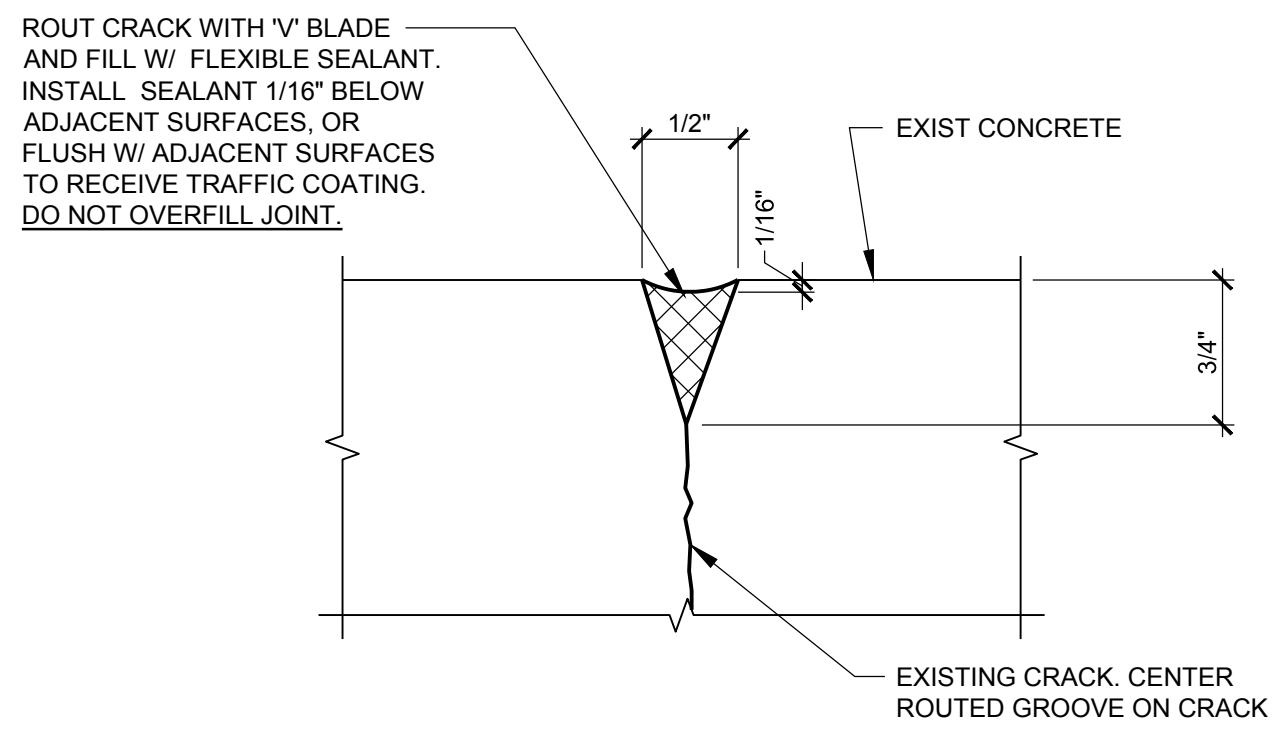

11.1 ROUT & SEAL RANDOM CRACKS (CRACKS 0.030\"/>



THESE DRAWINGS ARE PRELIMINARY AND RELEASED UNDER THE SUPERVISION OF ALFREDO E BUSTAMANTE, PE 94588

	2525 Bay Area Blvd Suite 400 Houston, TX 77058 281.280.0068 Ph 281.280.0373 Fax www.walkerrestoration.com	Job: Tranquility Parking Structure, Level 3	No. <b>R-503</b>
		Job No: 25-1863.00	
		Date: 07-31-2015	

ISSUED FOR BIDDING - NOT FOR CONSTRUCTION



REMOVE EXISTING SEALANT, PREPARE SUBSTRATE, AND FILL WITH FLEXIBLE SEALANT. INSTALL SEALANT 1/16" BELOW ADJACENT SURFACES, OR FLUSH WITH ADJACENT SURFACES TO RECEIVE TRAFFIC COATING. DO NOT OVERFILL JOINT.

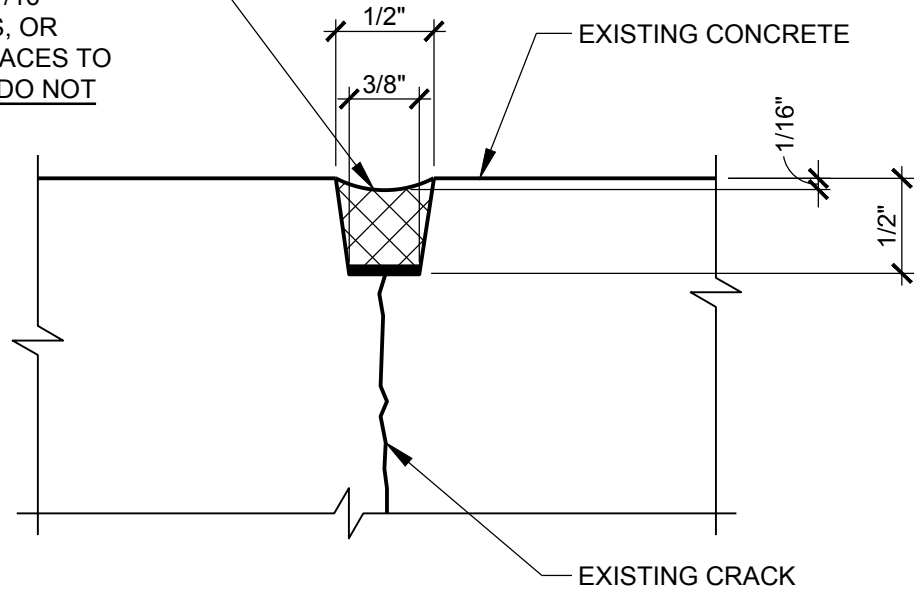

11.2

## JOINT SEALANT REPAIR

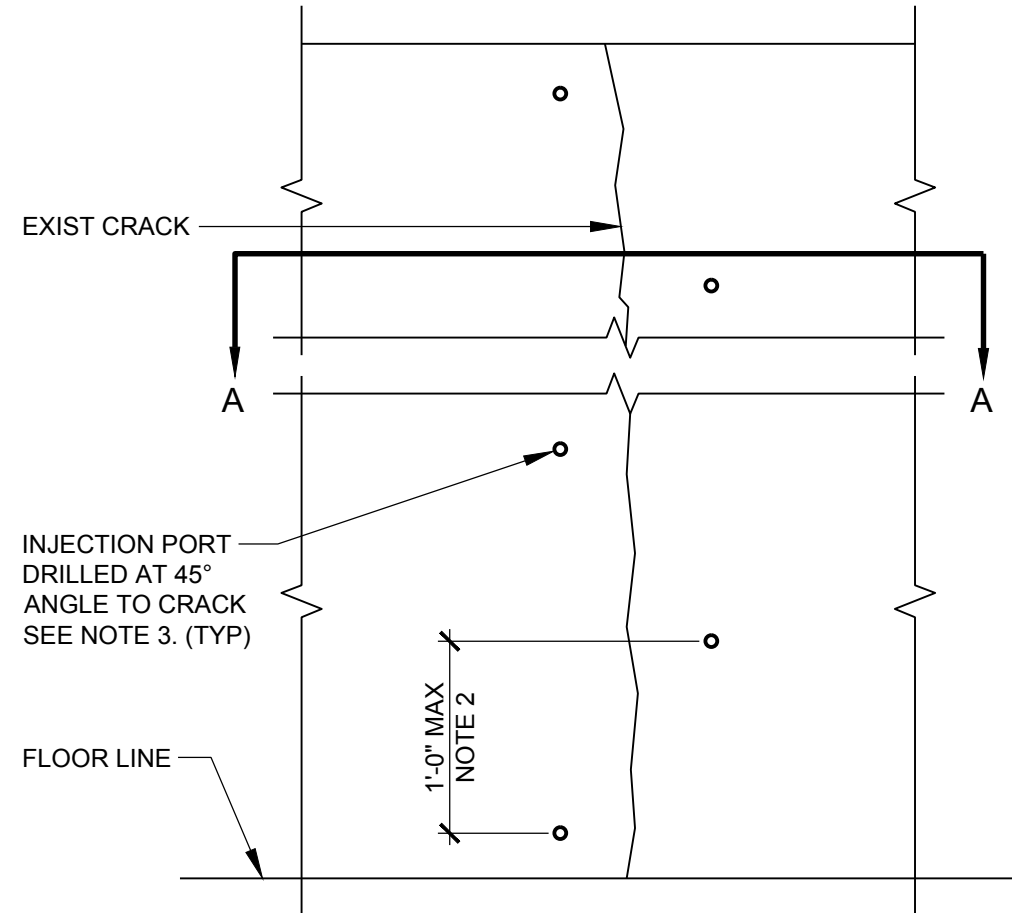
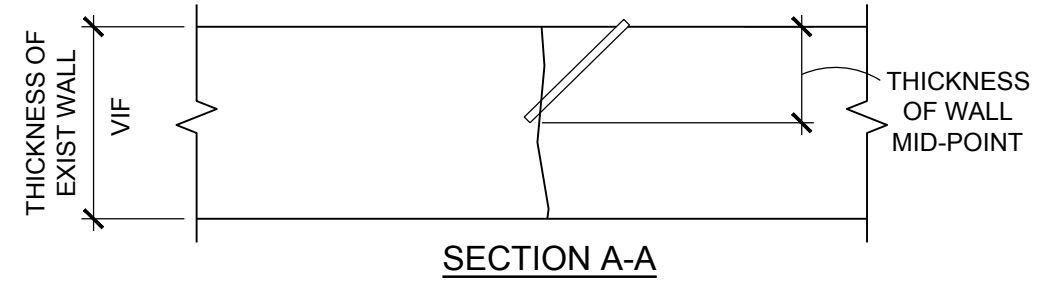

**NOTES:**

1. CLEAN SURFACE OF WALL TO IDENTIFY CRACK. DRILL INJECTION PORT AT A 45° ANGLE TO INTERSECT CRACK AT THE MID-DEPTH OF THE WALL.
2. STAGGER DRILL HOLES FROM ONE SIDE OF THE CRACK TO THE OTHER AT A MAXIMUM 12" OC SPACING.
3. FLUSH DRILL HOLES w/CLEAN WATER. SEE DETAIL 11.6.1 FOR ADDITIONAL INFORMATION.

11.6

## CHEMICAL GROUT INJECTION



THESE DRAWINGS ARE PRELIMINARY AND RELEASED UNDER THE SUPERVISION OF ALFREDO E BUSTAMANTE, PE 94588



2525 Bay Area Blvd  
Suite 400  
Houston, TX 77058  
281.280.0068 Ph  
281.280.0373 Fax  
www.walkerrestoration.com

Job: Tranquility Parking Structure, Level 3  
Job No: 25-1863.00  
Date: 07-31-2015

No.

R-504

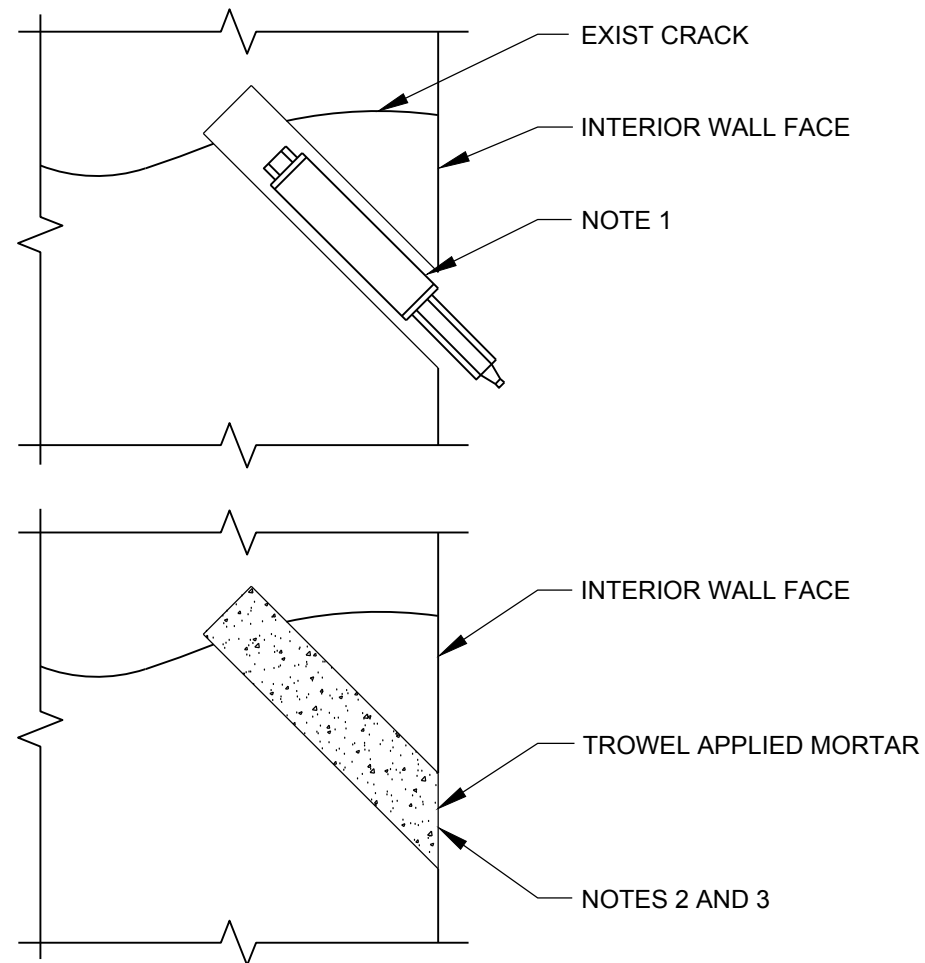

**NOTES:**

1. INSERT PACKERS INTO CLEAN DRILLED HOLE SO THAT TOP OF RUBBER SLEEVE IS BELOW CONCRETE SURFACE.
2. AFTER GROUTING PROCEDURE IS COMPLETE, REMOVE PACKER AND FITTINGS FROM HOLE AND REMOVE EXCESS GROUT FROM FACE OF WALL.
3. PATCH REMAINING HOLES WITH TROWEL APPLIED MORTAR. FILL ENTIRE HOLE FLUSH WITH SURFACE OF THE WALL TO MATCH THE EXISTING CONDITION.

**11.6.1 CHEMICAL GROUT INJECTION**



THESE DRAWINGS ARE PRELIMINARY AND RELEASED UNDER THE SUPERVISION OF ALFREDO E BUSTAMANTE, PE 94588



2525 Bay Area Blvd  
 Suite 400  
 Houston, TX 77058  
 281.280.0068 Ph  
 281.280.0373 Fax  
 www.walkerrestoration.com

Job:	Tranquility Parking Structure, Level 3
Job No:	25-1863.00
Date:	07-31-2015

No.  
**R-505**