

Miller Outdoor Theatre

Transverse Section - Downstage
 Motorized House Curtain Concept - Motor mounting floor beams

2015-06-23-SK-05

June 23, 2015
 1/2" = 1'-0"

durable canvas truck is equipped for years of commercial laundry collection, mail distribution or rugged material handling. Heavyweight canvas construction features wear-guard edges for abrasion protection. Water repellent finish resists weather and moisture damage, making it ideal for use as a laundry cart. Strong kiln-dried hardwood base, welded steel frame and four 4" non-marking rubber swivel casters handle heavy loads easily. Both ends of this canvas cart feature a large document pocket and a reinforced pull handle.

Product Specifications

LENGTH INCHES	53-1/4
WIDTH INCHES	36-1/4
HEIGHT INCHES	30-1/2
CAPACITY BUSHEL	24
COLOR FINISH	White
ASSEMBLY	Assembled
BRAND	Global Industrial
CONSTRUCTION	Canvas
LIMITED WARRANTY	1 Year
OVERALL HEIGHT INCHES	37-1/4
WHEEL TYPE	Rubber Swivel



Dimensions

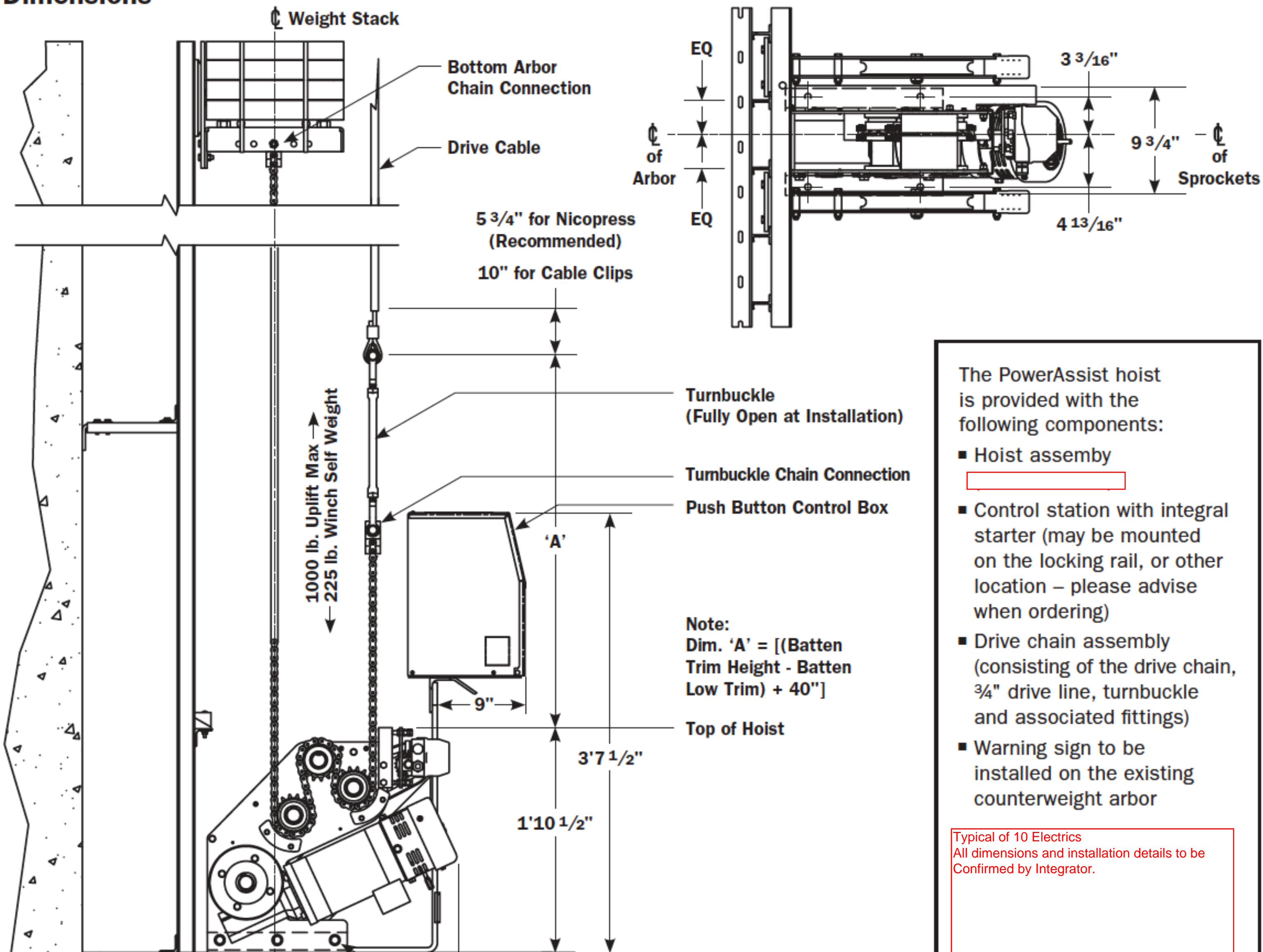

The PowerAssist hoist is provided with the following components:

- Hoist assembly
- Control station with integral starter (may be mounted on the locking rail, or other location – please advise when ordering)
- Drive chain assembly (consisting of the drive chain, 3/4" drive line, turnbuckle and associated fittings)
- Warning sign to be installed on the existing counterweight arbor

*Typical of 10 Electrics
 All dimensions and installation details to be Confirmed by Integrator.*

PowerAssist Hoist

Service

208, 230, or 480VAC, 3 ϕ , 60Hz
3W + GND
By others

Disconnect

30A, 3 Pole, N.F.
by others

3 - #12AWG THHN
1 - #12AWG THHN GND
Installed by others

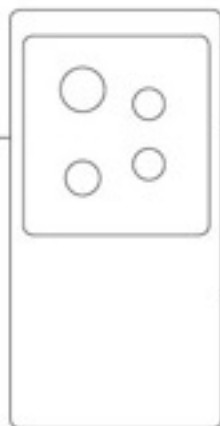

Starter/Control Cabinet
16.25"H x 6.62"W x 11.18" D
Located at locking rail

3 - #12AWG THHN Motor Leads
1 - #12AWG THHN GND
2 - #14AWG Brake Leads
Flex conduit tail with
conductors provided;
terminations in starter/control
cabinet by others



Motor
3 ϕ , 60Hz, 1.5 HP



Rotary Limit Switch
Four (4) element,
mounted on winch frame

6 - #14AWG THHN
1 - #14AWG THHN GND
Flex conduit tail with conductors
provided; terminations in
starter/control cabinet by others

Typical of 10 Electrics.
All electrical work by integrator.
Installation by licensed contractor.

